



GE Fanuc Automation

Programmable Control Products

*Series 90™ -70
Programmable Controller*

Data Sheet Manual

GFK0600F

November 1999

Warnings, Cautions, and Notes as Used in this Publication

Warning

Warning notices are used in this publication to emphasize that hazardous voltages, currents, temperatures, or other conditions that could cause personal injury exist in this equipment or may be associated with its use.

In situations where inattention could cause either personal injury or damage to equipment, a Warning notice is used.

Caution

Caution notices are used where equipment might be damaged if care is not taken.

Note

Notes merely call attention to information that is especially significant to understanding and operating the equipment.

This document is based on information available at the time of its publication. While efforts have been made to be accurate, the information contained herein does not purport to cover all details or variations in hardware or software, nor to provide for every possible contingency in connection with installation, operation, or maintenance. Features may be described herein which are not present in all hardware and software systems. GE Fanuc Automation assumes no obligation of notice to holders of this document with respect to changes subsequently made.

GE Fanuc Automation makes no representation or warranty, expressed, implied, or statutory with respect to, and assumes no responsibility for the accuracy, completeness, sufficiency, or usefulness of the information contained herein. No warranties of merchantability or fitness for purpose shall apply.

The following are trademarks of GE Fanuc Automation North America, Inc.

Alarm Master	Genius	ProLoop	Series Three
CIMPLICITY	Helpmate	PROMACRO	VersaMax
CIMPLICITY 90-ADS	Logicmaster	Series Five	VersaPro
CIMSTAR	Modelmaster	Series 90	VuMaster
Field Control	Motion Mate	Series One	Workmaster
GEnet	PowerTRAC	SeriesSix	

Preface

The Series 90™ -70 Programmable Logic Controller and its associated modules have been tested and found to meet or exceed the requirements of FCC Rule, Part 15, Subpart J. The FCC requires the following note to be published.

NOTE

This equipment generates, uses, and can radiate radio frequency energy and if not installed in accordance with the instruction manual, may cause interference to radio communications. It has been tested and found to comply with the limits of a Class A computing device pursuant to Subpart J of Part 15 of FCC Rules, which are designed to provide reasonable protection against such interference when operated in a commercial environment. Operation of this equipment in a residential area is likely to cause interference, in which case the user at his own expense will be required to take whatever measures may be required to correct the interference.

The Canadian Department of Communications requires the following note to be published.

NOTE

This digital apparatus does not exceed the Class A limits for radio noise emissions from digital apparatus set out in the radio interference regulations of the Canadian Department of Communications.

The following statements are required to appear for Class I Div 2 Hazardous Locations.

1. EQUIPMENT LABELED WITH REFERENCE TO CLASS I, GROUPS A, B, C, and D, DIV. 2 HAZARDOUS LOCATIONS IS SUITABLE FOR USE IN CLASS I, DIVISION 2, GROUPS A, B, C, D OR NON-HAZARDOUS LOCATIONS ONLY.
2. WARNING - EXPLOSION HAZARD - SUBSTITUTION OF COMPONENTS MAY IMPAIR SUITABILITY FOR CLASS I, DIVISION 2.
3. WARNING - EXPLOSION HAZARD - DO NOT DISCONNECT EQUIPMENT UNLESS POWER HAS BEEN SWITCHED OFF OR THE AREA IS KNOWN TO BE NON-HAZARDOUS.
4. ALL UNUSED SLOTS IN ALL BASEPLATES SHOULD BE POPULATED WITH A BLANK SLOT INTERRUPT JUMPER, IC697ACC722, OR EQUIVALENT WHEN THERE ARE MODULES INSTALLED TO ITS RIGHT WHICH MAY INTERRUPT THE CPU.

How to Find a Data Sheet in This Manual

To find the location of a data sheet in this manual:

(A). If you know the product name look for it in the Table of Contents. Its page number (at bottom of page) is listed (for example, page 5-1 is the first page of the VME Integrator Rack data sheet).

(B). Use the Index to search for a data sheet by either product category and name, product catalog number (IC.....), or by data sheet number (GFK-....).

For more information on finding data sheets in this manual, *go to the next page*.

This manual includes all currently available hardware data sheets for the Series 90-70 Programmable Logic Controller (PLC) under a single GE Fanuc publication number: GFK-0600F. On a module-by-module, and a unit-by-unit basis, this manual provides a complete hardware description of the Series 90-70 PLC product line.

⇒ How Data Sheets are Arranged in this Manual

The data sheets in this manual are arranged in categories by type. They can easily be found by looking in the Table of Contents or the Index.

⇒ Look in the Table of Contents

You can find a data sheet by looking in the *Table of Contents* under the heading (General Information, PLC CPUs, etc.) for the product type; each data sheet is then listed by product name (type of module), catalog number (IC. . .), and number (GFK) of the data sheet. Following is an example Table of Contents entry.

Product Type ⇒	PLC CPUs	12-1
Specific Data Sheet ⇒	12 MHz, 32 Kbyte, Central Processing Unit (IC697CPU731) data sheet GFK-0159J	12-1

The page numbers for the data sheets, as listed in the Table of Contents, are sequential in this manual and are located at the bottom of each data sheet page. Note that each data sheet is numbered according to its location in the manual. The first data sheet starts with 1-1, the 12th data sheet starts with 12-1, etc.). The page numbers for individual data sheets remain intact at the top of the data sheet (that is, 1 through 4, 1 through 8, etc.).

⇒ Look in the Index

You can also find a particular data sheet in the index. The index lists data sheets by product type and name, catalog number (IC697XXXXYY), data sheet number (GFK-XXXX), and the page number in this manual. Following are example index entries for the CPU listed above

CPUs
 12 MHz 32 Kbyte IC697CPU731, 12-1
 GFK-0159, CPU 12 MHz 32 Kbyte, 12-1
 IC697CPU731, CPU 12 MHz 32 Kbyte, 12-1

Content of Data Sheets

A data sheet is a user-oriented document, packaged with each Series 90-70 PLC module, which contains information specific to the module it accompanies. The format of the data sheet is standardized and includes the following sections (if applicable):

- Features
- Functions
- General Description
- Installation
- Field Wiring
- Calibration and Data Format
- Specifications
- Ordering Information

A data sheet only provides information for hardware installation of the module in the Series 90-70 system. Operation and programming of the modules is discussed in other Series 90-70 documents (see *Related Publications*). The audience for these documents is assumed to include electricians, technicians, engineers and those who are familiar with digital electronics and industrial control equipment.

Revisions to This Document

This version of the Series 90-70 Data Sheet manual has been revised to include all current versions of applicable Series 90-70 data sheets. It contains new data sheets and revisions that have been made to data sheets that were in the previous version of this manual (GEK-0600E). A data sheet (GFK-0867) - *GE Fanuc Product Agency Approvals, Standards, General Specifications*, which is at the front of the manual, lists and describes the standards to which GE Fanuc products comply.

For those installations having more stringent installation requirements where compliance to standards or directives from the Federal Communications Commission, the Canadian Department of Communications, or the European Union is necessary - refer to GFK-1179, *Installation Requirements for Conformance to Standards*.

References have been made on applicable data sheets to state that programming and/or configuration can be done either by MS-DOS® (Logicmaster 90-70), or Windows® (Control) software products. A note has been added, where applicable, after module specifications regarding availability of Conformal Coat option, or Low Temperature Testing option.

New and Revised Data Sheets

The following data sheets are new or have been revised since the previous version of this manual was printed.

Data Sheet Number	Title of Data Sheet	Catalog Number	Page Number
GFT-102H	ISO 9000 Registration (Quality System)	Allproducts	1-1
GFK-0867F	GE Fanuc Product Agency Approvals, Standards, General Specifications	Products listed	2-1
GFK-0079K	Standard Racks - Front and Rear Mount	IC697CHS750/790/791 4-1	
GFK-0684G	VME Integrator Racks, 17-Slot Front and Rear Mount	IC697CHS782/783.	5-1
GFK-0637G	Rack Fan Assembly	IC697ACC721/724/744 6-1	
GFK-1120D	64 MHz, 32-Bit, Floating Point, 1 Mbyte Memory CPU	IC697CPM925	18-1
GFK-1429F	96 MHz, 32-Bit, Floating Point, 512 Kbyte (Slow) Memory CPU	IC697CPX772.	19-1
GFK-1431F	96 MHz, 32-Bit, Floating Point, 1 Mbyte Memory CPU	IC697CPX782.	20-1
GFK-1433E	96 MHz, 32-Bit, Floating Point, 6 Mbyte (Medium) Memory CPU	IC697CPX928.	21-1
GFK-1435E	96 MHz, 32-Bit, Floating Point, 1 Mbyte Fast Memory CPU	IC697CPX935.	22-1

© MS-DOS and Windows are registered trademarks of Microsoft Corporation.

GFK-1437C	96 MHz, 32-Bit, FP, 512 Kbyte Memory CPU	IC697CGR772	23-1
	for CPU redundancy Applications		
GFK-1439C	96 MHz, 32-Bit, FP, 1 Mbyte Fast Memory CPU	IC697CGR935	24-1
	for CPU redundancy Applications		
GFK-1215B	64 MHz, 32-Bit, Floating Point, 1 Mbyte Memory for Triple Modular Redundancy Systems	IC697CPM790	27-1
GFK-1167C	64 MHz, 32-Bit, Floating Point, 1 Mbyte Memory CPU	IC697CPM790	31-1
GFK-1002E	FIP Bus Controller	IC697BEM742/744	62-1
GFK-1309E	Ethernet Interface (Type 2)	IC697CMM742	71-1
GFK-0834D	Redundancy Communications Module	IC697RCM711	72-1
GFK-1663E	RS-485 Port Isolator	IC690ACC903	78-1

Removed Data Sheets

The following data sheets which were in the previous version of this manual were removed due to the following: (1) product discontinued, (2) product has been replaced by a new version of the product, (3) a new data sheet created, or (4) information in the data sheet has been added to the applicable user's manual. Note that even though a data sheet is no longer in this manual, it may still be ordered. Consult your local GE Fanuc PLC distributor or GE Fanuc sales office for details.

Data Sheet Number	Title of Data Sheet	Catalog Number
GFK-0802C	32 MHz, 32-Bit, Floating Point CPU replaced by IC697CPM915, described in GFK-1119	IC697CPM914
GFK-0857B	64 MHz, 32-Bit, Floating Point CPU replaced by IC697CPM925, described in GFK-1120	IC697CPM924
GFK-0550E	RS-422/RS-485 to RS-432 Converter (IC690ACC900)	IC690ACC900

Related Publications:

- *GFK-0255 - Series 90™ Programmable Coprocessor Module and Support Software User's Manual*
- *GFK-0256 - MegaBasic™ Programming Language Reference Manual*
- *GFK-0262 - Series 90™ - 70 Programmable Controller Installation Manual*
- *GFK-0263 - Logicmaster™ 90-70 Programming Software User's Manual*
- *GFK-0265 - Series 90™ - 70 Reference Manual for Logicmaster™ Users*
- *GFK-0398 - Series 90™ - 70 Genius® Bus Controller User's Manual*
- *GFK-0401 - Workmaster II® PLC Programming Unit Guide to Operation*
- *GFK-0413 - GENet™ System Manager Software User's Manual*
- *GFK-0448 - User's Guide to Integration of 3rd Party VMEModules*
- *GFK-0487 - Series 90™ PCMD evelopment Software (PCOP) User's Manual*
- *GFK-0499 - CIMP LICITY® 90-ADS Alphanumeric Display System User's Manual*
- *GFK-0529 - Series 90™ SNP Communications User's Manual*
- *GFK-0579 - Series 90™ - 70 Remote I/O Scanner User's Manual*
- *GFK-0582 - Series 90™ PLC Serial Communications User's Manual*
- *GFK-0585 - Series 90™ PLC SNP Communications Driver User's Manual*
- *GFK-0641 - CIMP LICITY® 90-ADS Alphanumeric Display System Reference Manual*
- *GFK-0644 - Series 90™ - 70 I/O Link Interface Module User's Manual*
- *GFK-0685 - Series 90™ Programmable Controllers Flow Computer User's Manual*
- *GFK-0727 - Series 90™ - 70 PLC State Logic Processor User's Guide*
- *GFK-0730 - Series 90™ - 70 PLC OnTOP User's Guide*
- *GFK-0731 - Series 90™ - 70 PLC ECLiPS User's Manual*
- *GFK-0787 - Genius® Modular Redundancy User's Manual*
- *GFK-0827 - Series 90™ - 70 Hot Standby CPU Redundancy User's Guide*
- *GFK-0854 - Series 90™ Sequential Function Chart Programming Language User's Manual*
- *GFK-0870 - Host Communications Toolkit for C/C++ Applications User's Manual*
- *GFK-1004 - TCP/IP Ethernet Communications for the Series 90™ - 70 PLC User's Manual*
- *GFK-1026 - Host Communications Drivers for Microsoft® Windows™ User's Manual*
- *GFK-1029 - Logicmaster™ 90-70 Ethernet TCP/IP User's Manual*
- *GFK-1062 - Series 90™ - 70 High Speed Counter User's Manual*
- *GFK-1179 - Installation Requirements for Conformance to Standards*
- *GFK-1192 - Series 90-70 System Manual for Control Software Users*
- *GFK-1295 - Control User's Manual*
- *GFK-1527 - Series 90-70 Enhanced Hot Standby CPU Redundancy User's Guide*
- *GFK-1541 - TCP/IP Ethernet Communications for the Series 90 PLC User's Guide*

We Welcome Your Comments and Suggestions

At GE Fanuc Automation, we strive to produce quality technical documentation. After you have used this manual, please take a few moments to complete and return the Reader's Comment Card located on the next page.

Henry A. Konat
Technical Writer

General Information	1-1
ISO 9000 Registration (Quality System – ISO 9000 Registration) datasheet GFT-102H	1-1
GE Fanuc Product Agency Approvals, Standards, General Specifications datasheet GFK-0867F	2-1
Programmable Control Products:	
Lithium Battery Material Safety Data Sheet (Part No: 44A724534-001) datasheet GFK-0638A	3-1
PLC Racks	4-1
Five Slot, Rear Mount - IC697CHS750 Nine Slot, Rear Mount - IC697CHS790 Nine Slot, Front Mount - IC697CHS791 (Standard Racks - Front and Rear Mount) datasheet GFK-0079K	4-1
VME Integrator Racks, 17 Slot Front and Rear Mount (IC697CHS782/783) datasheet GFK-0684G	5-1
Rack Fan Assembly (IC697ACC721/724/744) datasheet GFK-0637E	6-1
Power Supplies	7-1
24 VDC, 90W Power Supply Module (IC697PWR724/CE697PWR724) datasheet GFK-1047F	7-1
48 VDC 90W Power Supply Module (IC697PWR748/CE697PWR748) datasheet GFK-1061D	8-1
120/240 VAC or 125 VDC, 55W Power Supply Module (IC697PWR710/712) datasheet GFK-1388A	9-1
Power Supply Module, 100W, 120/240 VAC or 125 VDC (IC697PWR711/713) datasheet GFK-1448B	10-1
Power Supply Adapter Module (IC697PWR720) datasheet GFK-0626D	11-1
PLC CPUs	12-1
12 MHz, 32 Kbyte Central Processing Unit (IC697CPU731) datasheet GFK-0159J	12-1
12 MHz, Expandable Central Processing Unit (IC697CPU771) datasheet GFK-0349F	13-1
12 MHz Expandable, Floating Point Central Processing Unit (IC697CPU772) datasheet GFK-0588E	14-1
16 MHz, 32-Bit, Expandable Central Processing Unit (IC697CPU781) datasheet GFK-0766D	15-1
16 MHz, 32-Bit, Expandable, Floating Point Central Processing Unit (IC697CPU782) datasheet GFK-0767D	16-1
32 MHz 32-Bit Floating Point Central Processing Unit, 1 Mbyte Memory (IC697CPM915) datasheet GFK-1119B	17-1
64 MHz, 32-Bit Floating Point Central Processing Unit, 1 Mbyte Memory (IC697CPM925) datasheet GFK-1120D	18-1

Contents

96 MHz, 32-Bit Point, 512 Kbyte (Slow) Memory Central Processing Unit (IC697CPX772) datasheet GFK-1429F	19-1
96 MHz, 32-Bit, Floating Point, 1 Mbyte Memory Central Processing Unit (IC697CPX782) datasheet GFK-1431F	20-1
96 MHz, 32-Bit, Floating Point, 6 Mbyte (Medium) Memory Central Processing Unit (IC697CPX928) datasheet GFK-1433E	21-1
96 MHz, 32-Bit, Floating Point, 1 Mbyte Fast Memory Central Processing Unit (IC697CPX935) datasheet GFK-1435E	22-1
96 MHz, 32-Bit Floating Point, 512 KByte Memory Central Processing Unit for CPU Redundancy Applications (IC697CGR772) datasheet GFK-1437C	23-1
96 MHz, 32-Bit Floating Point, 1 MByte Fast Memory Central Processing Unit for CPU Redundancy Applications (IC697CGR935) datasheet GFK-1439C	24-1
16 MHz, 32-Bit Expandable Central Processing Unit for IC66* Triple Modular Redundancy Systems (IC697CPU788) datasheet GFK-0806D	25-1
16 MHz, 32-Bit Expandable Central Processing Unit for IC66* Triple Modular Redundancy Systems (IC697CPU789) datasheet GFK-0807D	26-1
64 MHz, 32-Bit Floating Point Central Processing Unit, 1 Mbyte Memory, for IC66* Triple Modular Redundancy Systems (IC697CPM790) datasheet GFK-1215B	27-1
16 MHz, 32-Bit Floating Point Expandable Central Processing Unit for Hot Stand- by CPU Applications (IC697CPU780) datasheet GFK-0837C	28-1
16 MHz, 32-Bit Floating Point, State Logic Central Processing Unit (IC697CSE784) datasheet GFK-1035C	29-1
64 MHz, 32-Bit Floating Point State Logic Central Processing Unit (IC697CSE924) datasheet GFK-1036B	30-1
64 MHz, 32-Bit Floating Point Central Processing Unit 1 Mbyte Memory, State Logic (IC697CSE925) datasheet GFK-1167C	31-1
Expansion Memory	32-1
CMOS Expansion Memory (IC697MEM713/715/717/719) datasheet GFK-0160F	32-1
32-Bit CMOS Expansion Memory (IC697MEM731/732/733/735) datasheet GFK-0531E	33-1
Coprocessor Modules	34-1
Programmable Coprocessor Module (IC697PCM711) datasheet GFK-0164G	34-1

Alphanumeric Display Coprocessor (ADC) (IC697ADC701) datasheet GFK-0521E	35-1
Discrete Input Modules	36-1
12 Volt AC, 32-Point Input Module (IC697MDL252) datasheet GFK-0756D	36-1
24 Volt AC, 32-Point Input Module (IC697MDL253) datasheet GFK-0757C	37-1
48 Volt AC, 32-Point Input Module (IC697MDL254) datasheet GFK-0784C	38-1
120 Volt AC, 32-Point Input Module (IC697MDL250) datasheet GFK-0084J	39-1
120 Volt AC, Isolated, 16-Point Input Module (IC697MDL240) datasheet GFK-0375E	40-1
120 Volt AC, 16-Point Input Module (IC697MDL251) datasheet GFK-0718C	41-1
240 Volt AC, Isolated 16-Point Input Module (IC697MDL241) datasheet GFK-0376G	42-1
12 Volt DC Positive/Negative Logic, 32-Point Input Module (IC697MDL652) datasheet GFK-0378F	43-1
24 Volt DC Positive/Negative Logic, 32-Point Input Module (IC697MDL653) datasheet GFK-0379F	44-1
48 Volt DC Positive/Negative Logic, 32-Point Input Module (IC697MDL654) datasheet GFK-0380G	45-1
125 Volt DC Positive/Negative Logic, 16-Point Input Module (IC697MDL640) datasheet GFK-0719D	46-1
TTL, Negative Logic, 32-Point Input Module (IC697MDL651) datasheet GFK-0377D	47-1
Interrupt Module, 14 Point, 24 Volt DC Positive/Negative Logic (IC697MDL671) datasheet GFK-0880C	48-1
Discrete Output Modules	49-1
120 Volt AC 0.5 Amp, 32-Point Output Module (IC697MDL350) datasheet GFK-0081H	49-1
120 Volt AC 2 Amp, 16-Point Output Module (IC697MDL340) datasheet GFK-0082H	50-1
120/240 Volt AC, 2 Amp Isolated 12-Point Output Module (IC697MDL341) datasheet GFK-0382J	51-1
5/48 Volt DC 0.5 Amp Negative Logic, 32-Point Output Module (IC697MDL753) datasheet GFK-0383F	52-1
12 Volt DC 0.5 Amp, 32-Point Output Module (IC697MDL752) datasheet GFK-0381E	53-1
24/48 Volt DC, 0.5 Amp, 32-Point Output Module (IC697MDL750) datasheet GFK-0085G	54-1
24/48 Volt DC, 2 Amp, 16 Point Output Module (IC697MDL740) datasheet GFK-0086G	55-1
Relay Output, 16 Point Module (IC697MDL940) datasheet GFK-0384E	56-1

Contents

Analog Modules	57-1
Analog Input System, High Level, 16 Channels Base Converter Module - IC697ALG230, Current Expander Module - IC697ALG440 Voltage Expander Module - IC697ALG441 datasheet GFK-0385F	57-1
High Level Analog Output System - Voltage/Current Module (IC697ALG320) datasheet GFK-0388G	58-1
Special Applications Modules	59-1
High Speed Counter (IC697HSC700) datasheet GFK-1057D	59-1
State Logic Processor Module (SLP) (AD697SLP711) datasheet GFK-0734C	60-1
Bus Expansion Modules	61-1
Bus Controller Module (IC697BEM731/734) datasheet GFK-0165G	61-1
FIP Bus Controller (IC697BEM742/744) datasheet GFK-1002E	62-1
Bus Transmitter Module (IC697BEM713) datasheet GFK-0161H	63-1
Bus Receiver Module (IC697BEM711) datasheet GFK-0162F	64-1
Remote I/O Scanner (IC697BEM733/735) datasheet GFK-0539C	65-1
I/O Link Interface Module (IC697BEM721) datasheet GFK-0645C	66-1
I/O Interface Module for the IC600 PLC (IC697BEM761) datasheet GFK-0096F	67-1
Communications Modules	68-1
Ethernet Controller (IC697CMM741) datasheet GFK-0532K	68-1
Ethernet Interface (Type 2) (IC697CMM742) datasheet GFK-1309E	69-1
Serial Communications Module for State Logic CPU (IC697CMM712) datasheet GFK-1039B	70-1
Communications Coprocessor Module (CMM) (IC697CMM711) datasheet GFK-0370F	71-1
Redundancy Communications Module (IC697RCM711) datasheet GFK-0834D	72-1
Programmer Interface Modules	73-1
Work Station Interface (XT, AT) (IC640WMI910/310) datasheet GFK-0166F	73-1
Work Station Interface (PC/2) (IC640WMI920/320) datasheet GFK-0281D	74-1

Accessories	75-1
Cables - I/O	
datasheet GEK-83517E	75-1
Cable - Power Supply Extension (IC697CBL700/713)	
datasheet GFK-0153G	76-1
Cables - PCM to Programmer (IC690CBL701/702/705)	
datasheet GFK-0359F	77-1
RS-485 Port Isolator (IC697ACC903)	
datasheet GFK-1663A	78-1
Miniconverter Kit (IC690ACC901)	
datasheet GFK-0682C	79-1
Blank Slot Interrupt Jumper (IC697ACC722)	
datasheet GFK-0589A	80-1
Cable Shield Clamping Assembly (IC697ACC736)	
datasheet GFK-1187A	81-1
VME Option Kit (IC697ACC715)	
datasheet GFK-0552C	82-1



GFT-102H
April 1998

Quality System - ISO 9000 Registration

GE Fanuc Automation was one of the first manufacturing companies in the United States to be registered to ISO 9001 Quality Standards. ISO 9001 is the most comprehensive in a series of standards in the ISO 9000 Series which assures customers of a sound quality system in Marketing, Design, Manufacturing, and Service.

ISO 9000 is a series of quality standards which define how you can establish, document and maintain an effective quality system which demonstrates to your customers your ability to supply them high quality products. The standards provide a framework for implementing a working quality management system.

The International Organization for Standardization (ISO) has published ISO Quality System standards (ISO 9000 Series) using submissions from its member countries. These standards have been so widely accepted that most industrialized countries have replaced their national standards with ISO 9000 series. The equivalents for ISO 9001 in the United States and United Kingdom are ANSI/ASQC Q9000-9004 and BS5750 part 1-4, respectively.

GE Fanuc has embraced the concept of ISO quality system management and registration. Ultimately the adoption of ISO 9000 standards will spread throughout the United

States, resulting in our suppliers and customers gaining registration status as well. Our supplier involvement is particularly significant since it will promote a common understanding of quality and continuous improvement throughout the process/product chain. GE Fanuc will accept ISO 9000 registration in lieu of a quality system audit. We have also modified our Supplier Quality System survey to include ISO 9000 series criteria.

The ISO 9000 Series includes a guidance document ISO 9004, and ISO 9001, 9002, and 9003 which address contractual requirements for quality systems and are used for external quality assurance assessment. ISO 9001 is the most comprehensive standard and it is defined as: "Quality Systems - Model for Quality Assurance in Design/Development, Production, Installation, and Servicing". This most comprehensive and stringent standard assesses the producer's ability to design as well as manufacture and test good product.

GE Fanuc completed the registration process successfully in June, 1991, being one of the first automation companies in this country to do so. In order to assure international acceptance of the registration, GE Fanuc is jointly registered by UL (USA) and BSI (UK). On-going surveillance visits by the above agencies will continue annually at a minimum to assure compliance to the standards.

The ISO 9001 registration numbers for GE Fanuc are: A2003 for UL and FM 13400 for BSI.

If there are any questions or inquiries about ISO, please call (804) 978-5000 and ask for the ISO Program Manager or the Business Quality Engineer.

Or write to either of the above at:

*GE Fanuc Automation North America, Inc.
P.O. Box 8106
Charlottesville, VA 22906*

General Information

GFK-0867F
August 1998

GE Fanuc Product Agency Approvals, Standards, General Specifications Genius® I/O Products, Series 90™ -30, Series 90™ -70, & VersaMax PLC Products Field Control™ Distributed I/O & Control Products

The products supplied by GE Fanuc are global products which are designed and manufactured with ISO9001 quality assurance for application in industrial environments throughout the world. They should be installed and used in conformance with product specific guidelines as well as the following agency approvals, standards and general specifications:

AGENCY APPROVALS OVERVIEW ¹		Comments
Quality Assurance in Design/Development, Production, Installation, & Servicing	ISO9001	Certification ⁴ by Underwriters Laboratories and BSI Quality Assurance
Safety for Industrial Control Equipment	UL508	Certification by Underwriters Laboratories
	C-UL⁵, CSA22.2, or 142-M1987	Certification by Underwriters Laboratories [C-UL ⁵] or Canadian Standards Association for selected Series 90, Genius, VersaMax, and Field Control modules
Safety for Hazardous Locations Class I, Div II, A, B, C, D	UL1604 with C-UL⁵	Certification by Underwriters Laboratory for Versa Max, Field Control, and selected Series 90 and-Genius modules
	FM3611	Certification by Factory Mutual for selected Genius and Series 90-70 modules
	CSA22.2, 213-M1987	Certification by Canadian Standards Association for selected Genius modules
Safety for Hazardous Locations Class I, Zone 2, A, B, C, D	CENELEC prEN50021	Certification by DEMKO through Underwriters Laboratory for selected Series 90-30 and Field Control modules, and VersaMax products
	UL2279 IEC 79-15	Certification by Underwriters Laboratory for Versa-Max products, and selected Series 90-30 and Field Control modules
European EMC and Low Voltage Directives	CE Mark	Certification by Competent Body for EMC Directive for selected modules

6 STANDARDS OVERVIEW ^{2, 4}		Conditions
ENVIRONMENTAL		
Vibration	IEC68-2-6	1G @57-150Hz, 0.012in p-p @10-57Hz
Shock	IEC68-2-27	15G, 11ms
Operating Temperature ³		0°C to 60°C: Series 90 [inlet], Genius [ambient], VersaMax[ambient] 0°C to 55°C: Field Control [ambient]
Storage Temperature		-40 °C to +85°C
Humidity		5% to 95%, non-condensing
Enclosure Protection	IEC529	Steel cabinet per IP54: protection from dust & splashing water

GFK-0867F
August 1998

GE Fanuc Product Agency Approvals, Standards, General Specifications

STANDARDS OVERVIEW ^{2, 4}		Conditions
EMC EMISSIONS		
Radiated, Conducted	CISPR 11/EN 55011 CISPR 22/EN 55022 47 CFR 15	“Industrial Scientific & Medical Equipment” (Group 1, Class A) “Information Technology Equipment” (Class A) referred to as FCC part 15, “Radio Devices” (Class A)
EMC IMMUNITY		[applies to CE Marked modules]
Electrostatic Discharge	EN 61000-4-2*	8KV Air, 4KV Contact
RF Susceptibility	EN 61000-4-3*	10V _{rms} / m 80Mhz to 1000Mhz, 80% AM
	ENV 50140/ENV 50204	VersaMax: All power supply, I/O, and communication modules
Fast Transient Burst	EN 61000-4-4*	2KV: power supplies, 1KV: I/O, communication
Surge Withstand	ANSI/IEEE C37.90a IEC 255-4	Damped Oscillatory Wave: 2.5KV: power supplies, I/O [12V-240V] Damped Oscillatory Wave: Class II, power supplies, I/O [12V-240V]
	EN 61000-4-5*	Field Control and VersaMax: 2 kV cm (P/S); 1 kV cm (I/O) VersaMax: All power supply, I/O, and communication modules
Conducted RF	EN 61000-4-6*	10V _{rms} , 0.15 to 80Mhz, 80% AM: comm. modules w/ cables >30m VersaMax: All power supply, I/O, and communication modules
ISOLATION		
Dielectric Withstand	UL508, UL840, IEC664	1.5KV for modules rated from 51v to 250v
POWER SUPPLY		
Input Dips, Variations	EN 61000-4-11*	During Operation: Dips to 30% and 100%, Variation for AC Ç 10%, Variation for DC Ç 20%

* EN 61000-4-x series of tests are technically equivalent to the IEC 1000-4-x and IEC 801-x series.

Note 1: Module specific approvals are listed on the GE Fanuc Electronic Bulletin Board Service [BBS]. The BBS can be reached at 804-978-5458 with the following modem settings: 14400 baud, 8 data bits, 1 parity bit, no stop bits. After accessing the BBS, select the BBS File area (PLC:AGENCYSTATUS) and the file (AGENSTDS.XLS)

Note 2: Refer to module specific data sheets & installation guidelines in the following publications:
GFK-0600, *Series 90-70 PLC Data Sheets Manual*; GFK-0262, *Series 90-70 PLC Installation Manual*;
GFK-0356, *Series 90-30 PLC Installation Manual*; GFK-0898, *Series 90-30 I/O Specifications Manual*;
GEK-90486-1, *Genius I/O System User's Manual*; GEK-90486-2, *Genius I/O Discrete and Analog Blocks User's Manual*;
GFK-0825, *Field Control Distributed I/O and Control System - Genius Bus Interface Unit User's Manual*;
GFK-0826, *Field Control Distributed I/O and Control System - I/O Module's User's Manual*;
GFK-1179, *Installation Requirements for Conformance to Standards*; GFK-1503, *VersaMax System PLC Reference Manual*;
GFK-1504, *VersaMax System I/O and Option Modules*; GFK-1535, *VersaMax System Network Communications User's Manual*.

Note 3: Selected modules may be derated.

Note 4: Applies to GE Fanuc products designed and built in Charlottesville.

Note 5: Modules comply with applicable CSA Standards as evaluated by UL. The C-UL mark is accepted throughout Canada.

® Genius is a registered trademark of GE Fanuc Automation North America, Inc.

™ Series 90, VersaMax, and Field Control are trademarks of GE Fanuc Automation North America, Inc.

General Information

Part No: 44A724534-001

GFK-0638A
May 1993

Programmable Control Products: Lithium Battery Material Safety Data Sheet

MATERIAL SAFETY DATA SHEET

Material Safety Data Sheet May be used to comply with OSHA's Hazard Communication Standard. 29 CFR 1910.1200. Standard must be consulted for specific requirements.	U.S. Department of Labor Occupational Safety and Health Administration (Non-Mandatory Form) Form Approved OMB No. 1218-0072
IDENTITY (As Used on Label and List) Lithium Battery BR-2/3A	Note: Blank spaces are not permitted. If any item is not applicable, or no information is available, the space must be marked to indicate that.

Section I

Manufacturer's Name Matsushita Micro Battery Ind. Co. Ltd.	Emergency Telephone Number Not Applicable
Address (Number, Street, City, State, and ZIP Code) One Matsushita-cho Moriguchi, Osaka	Telephone Number for Information 201-348-7499 T. Kuwamura
570 JAPAN	Date Prepared 7-15-87
Telephone # 06-991-1141 (Japan)	Signature of Preparer (optional)

Section II – Hazardous Ingredients/Identity Information

Hazardous Components (Specific Chemical Identity: Common Name(s))	OSHA PEL	ACGIH TLV	Other Limits Recommended	% (optional)
Lithium Metal = < 0.5 Grams Lithium				
Weight of lithium per cell = 0.44g				
(Approx. percent of total weight = 3.3 wt. %)				

Section III – Physical/Chemical Characteristics

Boiling Point	N/A	Specific Gravity (H ₂ O = 1)	
Vapor Pressure (mm Hg.)	N/A	Melting Point	180 °C
Vapor Density (AIR = 1)	N/A	Evaporation Rate (Butyl Acetate = 1)	N/A
Solubility in Water	N/A	Operating Temperature Range: -40° to +85° C/ -40° to +185° F	
Appearance and Odor	N/A	Storage Temperature Range: -40° to +85° C/ -40° to +185° F	

Section IV – Fire and Explosion Hazard Data

Flash Point (Method Used)	N/A	Flammable Limits	N/A	LEL	N/A	UEL	N/A
Extinguishing Media	Dry chemical or dry sand						
Special Fire Fighting Procedures	N/A						
Unusual Fire and Explosion Hazards	Fire and explosion is present only when battery is abused.						

THIS IS A REPRODUCTION OF THE MATERIAL SAFETY DATA SHEET PROVIDED BY THE BATTERY VENDOR.

GFK-0638A
May 1993

**Programmable Control Products:
Lithium Battery Material Safety Data Sheet**

Section V – Reactivity Data

Stability	Unstable		Conditions to Avoid	N/A
	Stable			
Incompatibility (Materials to Avoid)				
N/A				
Hazardous Decomposition or Byproducts				
N/A				
Hazardous Polymerization	May Occur		Conditions to Avoid	N/A
	Will Not Occur			

Section VI – Health Hazard Data

Route(s) of Entry:	Inhalation?	Skin?	Ingestion?
Health Hazards (Acute and Chronic)			
N/A			
Carcinogenicity:	NTP? N/A	IARC Monographs?	OSHA Regulated?
Signs and Symptoms of Exposure			
N/A			
Medical Conditions			
Generally Aggravated by Exposure	N/A		

Emergency and First Aid Procedure

Eyes/Skin Wash out the eyes/skin with water promptly. **Inhalation:** Rest, expose person to fresh air, use oxygen if available. **Ingestion:** Not toxic per tests with laboratory animals (rats). **Note to Physician:** Not toxic to the body, however it is best to wash out the solution with water promptly in an emergency.

Section VII – Precautions for Safe Handling and Use

Steps to Be Taken in Case Material is Released or Spilled

If the battery is accidentally broken and organic electrolyte (gamma-butyrolactone and LiBF₄ as a solute) leaks out, wipe it up with a cloth, and dispose of it in a plastic bag and put into a steel can. No outgasses during normal operation or at normal temperature because we use: Solvent: gamma-butyrolactone, 204°C boiling point, not toxic.
Solute: LiBF₄, neutral acid, not toxic.

Waste Disposal Method

It is recommended to discharge the battery to the end, to use up the metal lithium inside the battery, and to bury the discharged battery in soil.

Precautions to Be Taken in Handling and Storing

Unusual Fire and Explosion Hazard: In the abnormal case, example: Charge to higher than 5 volts at high amperage, the top may pop up.

Section VIII – Control Measures

Respiratory Protection (Specify Type)			
N/A			
Ventilation	Local Exhaust	N/A	Special
	Mechanical (General)	N/A	Other
Protective Gloves			Eye Protection
N/A			N/A
Other Protective Clothing or Equipment			
N/A			
Work/Hygienic Practices			
N/A			

THIS IS A REPRODUCTION OF THE MATERIAL SAFETY DATA SHEET PROVIDED BY THE BATTERY VENDOR.

PLC Racks

Standard Racks - Front and Rear Mount

GFK-0079K
November 1999

Five Slot, Rear Mount - IC697CHS750
Nine Slot, Rear Mount - IC697CHS790
Nine Slot, Front Mount - IC697CHS791

Features

- Accepts all IC697 PLC module types
- Rear mount racks mount in a 10" (254 mm) deep enclosure (fans normally not required)
- Front mount rack mounts in a standard 19" (480 mm) rack (fans normally not required)
- Accepts plug-in AC or DC IC697 power supply
- Provision for two rack operation from single power supply

NOTE: For Power Supply compatibility see page 5.

Functions

The Standard Nine-Slot Racks and the Five-Slot Rack for the IC697 programmable controller are used for all

CPU and I/O configurations. Each rack has provision for one power supply at the leftmost module position; and either nine additional slot locations (nine-slot rack) or five additional slot locations (five-slot rack).

Overall rack dimensions are 11.15" H x 19" W x 7.5" D (283mm x 483mm x 190mm) for the Nine-Slot Rack and 11.15" H x 13" W x 7.5" D (283mm x 320mm x 190mm) for the Five-Slot Rack. Slots are 1.6" wide except the power supply slot which is 2.4" wide.

Two racks can be interconnected to share a single power supply for applications having extended I/O requirements. A Power Supply Extension Cable kit (IC697CBL700) is available for such applications.

Each rack provides slot sensing for rack-type I/O modules designed for the IC697 PLC. No jumpers or DIP switches on the I/O modules are required for module addressing.

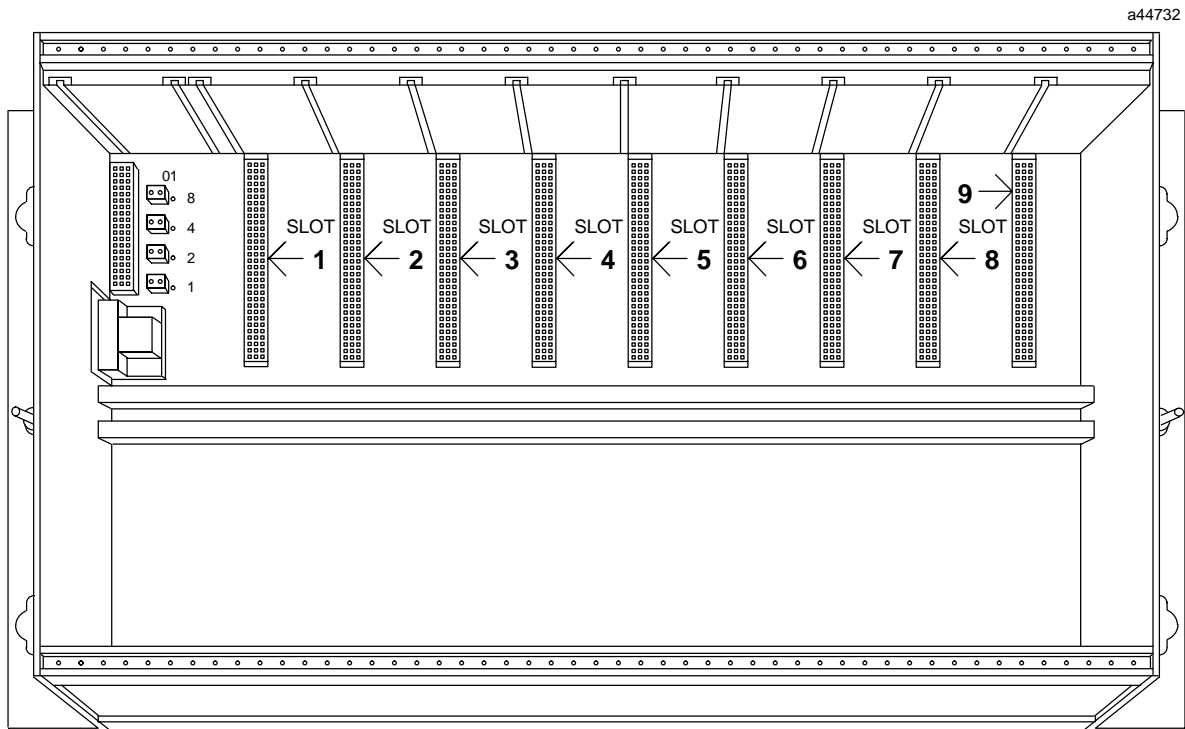

GFK-0079K
November 1999

Five Slot, Rear Mount - IC697CHS750
Nine Slot, Rear Mount - IC697CHS790
Nine Slot, Front Mount - IC697CHS791

Rack Outline Drawings

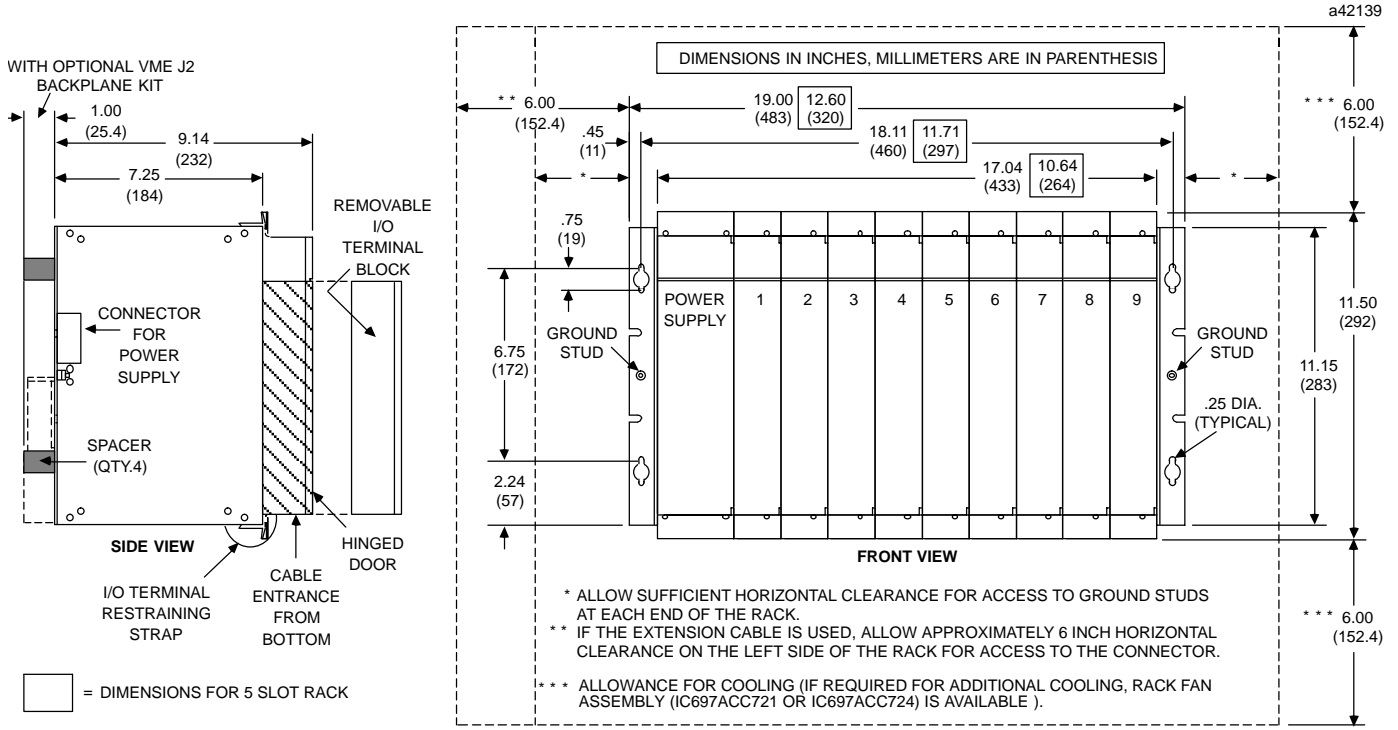

Figure 1. Outline Drawing for Standard Rear (Panel) Mount Rack

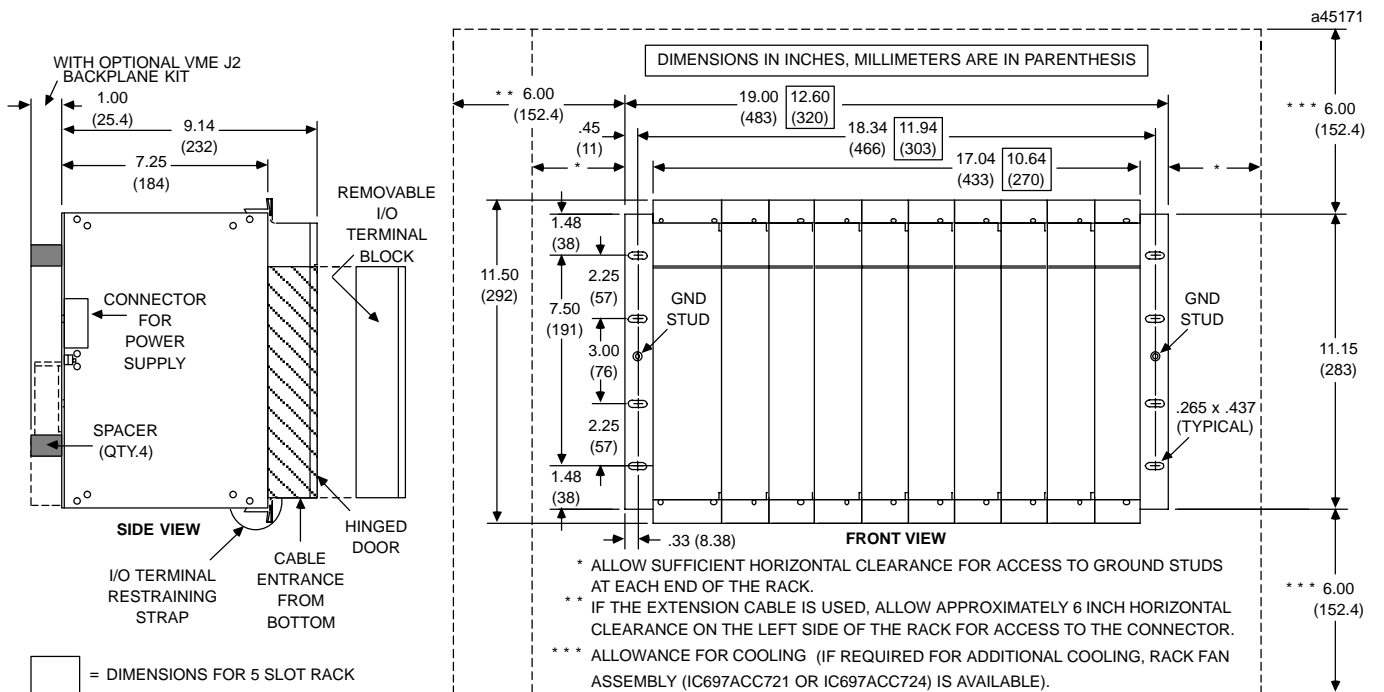

Figure 2. Outline Drawing for Standard Front (Rack) Mount Rack

Five Slot, Rear Mount - IC697CHS750
Nine Slot, Rear Mount - IC697CHS790
Nine Slot, Front Mount - IC697CHS791

GFK-0079K
November 1999

Rack Mounting

The rack must be mounted in the orientation as shown in Figures 1 and 2. Sufficient space must be left around the rack as shown to allow air flow for module cooling. The mounting requirements (either front or rear mount) must be determined according to the application and the proper rack ordered. Mounting flanges are an integral part of rack side panels and are installed at the factory.

A Rack Fan Assembly is available for mounting on the Nine-Slot Racks when required for installations where heat buildup could be a problem. The Rack Fan Assembly is available in three versions:

- IC697ACC721 for 120 VAC power source
- IC697ACC724 for 240 VAC power source
- IC697ACC744 for 24 VDC power source

Refer to GFK-0637C, or later for detailed information about the Rack Fan Assembly.

I/O Connector

These racks accommodate rack-type IC697 high-density I/O modules, which use a detachable field wiring terminal board. Each I/O module will accept up to forty AWG #14 (2.10mm²) wires. The wire bundle is routed out the bottom of the terminal board cavity where a cleat is provided for a tie wrap to secure the bundle to the terminal board housing.

Mechanical Keying

IC697 I/O modules are mechanically interlocked by means of a key to prevent inadvertent interchange of one module type for another (for example, AC type for DC type). A key unique to each module type is included with the module.

When the module is inserted into the rack, the key automatically latches onto the center rail of the rack, where it remains when the module is extracted. Only the correct module type can then be inserted into that rack slot.

If it is necessary to change the module location in the rack after the key has been latched onto the center rail of the rack, the key can be removed by pushing it upward to unhook the latch while pulling it off the rail. It may then be reinserted onto the module and the module inserted into the rack in the desired location.

Note

The power supply slot is unique - only the power supply can be installed in the left-most rack position.

Power Supply Extension Cable

For many applications, one power supply can provide the power requirements of two racks. Such dual-rack operation from a single power supply can be implemented if only 5 volt power of 5.2 amperes or less is required in the second rack.

A 3-foot (1 meter) Power Supply Extension Cable is available (see the Ordering Information on the last page of this data sheet) which provides the necessary interconnection. In addition to +5 volt power, the extension cable includes power sequencing signals necessary for proper system operation.

The Power Supply Extension cable attaches to a 9-pin D type connector located on the backplane. Access to the connector is via a hole in the left side of the rack as shown in the outline drawing. Adequate clearance (approximately 6 inches 152.4mm)) must be provided on the left side of the rack for access to the connector.

The Power Supply Extension cable must be secured before power is applied. It must not be disconnected during system operation.

Slot Addressing

The IC697 PLC system allows user configuration of I/O point references for modules in a rack without the need for board address DIP switches or jumpers. The address structure is described in the applicable *Programmable Controller Installation Manual*. Configuration is done with the MS-DOS® or Windows® programming software configurator function. For more information on configuration, see the applicable *Programming Software User's Manual*.

Rack Number

Multiple racks in a system must be assigned a rack number from 0 to 7; the CPU rack is always Rack 0. The PLC determines the number of each rack in the system from four binary-encoded jumpers on the rack's backplane. These jumpers are located on the backplane directly behind the power supply, which must be removed to gain access to the jumpers.

GFK-0079K
November 1999

Five Slot, Rear Mount - IC697CHS750
Nine Slot, Rear Mount - IC697CHS790
Nine Slot, Front Mount - IC697CHS791

© MS-DOS and Windows are registered trademarks of Microsoft Corporation.

To set the rack number, move the jumpers corresponding to 1, 2, 4, and 8 bits to either the 0 or 1 position. The sum of the digits in the 1 position equals the desired rack number. For example, rack number 2 would have the 1, 4 and 8 bit jumpers in the 0 position and the 2 bit jumper in the 1 position as shown below.

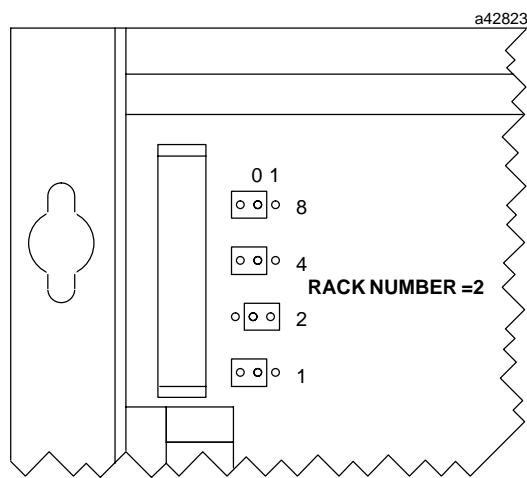

Figure 3. Rack Number Jumpers

Safety Ground

The ground lug on either side of the rack must be connected to earth ground with not less than an AWG #12 (3.33mm²) wire. The ground lugs are #8-32.

Warning

If the ground lug is not connected to earth ground, the rack is not grounded. The rack must be grounded to minimize electrical shock hazard which may result in severe personal injury.

Shield Ground

The bottom rail of the rack is used for module shield grounding. Some IC697 I/O modules have a ground clip that contacts the conductive bottom rail when the module is fully inserted. Shield connections in the user connectors are routed to this ground clip via conductors on the module.

System Noise Immunity

Three easy steps must be taken to properly ground the IC697 programmable controller system to reduce the possibility of errors due to electrical noise.

1. Make sure that the power supply mounting screws, especially the bottom two, are properly secured.
2. The GND terminal on the power supply must be connected to the GND terminal on either side of the rack using AWG #12 (3.33 mm²) wire. Use of a ring terminal and star washer is recommended.
3. The GND terminal on the rack must be connected to a good earth ground.

Module Retention

IC697 I/O modules have molded latches that automatically snap onto the upper and lower rails of the rack when the module is fully inserted. Optionally, M2.5x8 screws may be used to secure the modules to the rack for high vibration applications.

Warning

Do not remove (or insert) modules when either the programmable controller power supply or any externally-connected power sources are on. Hazardous voltages may exist. Personal injury, damage to the module or improper operation of the device or process being controlled may result.

To remove an IC697 module, first remove the field half of the terminal board (if it is an I/O module), then grasp the top and bottom of the module to depress the latch releases while pulling the module out. For more detailed information on removing I/O terminal boards, refer to the applicable *Programmable Controller User's manual* or individual data sheets for I/O modules.

If M2.5x8 screws have been used to secure modules to the rack, remove the screws before removing the modules.

A blank faceplate is available to cover unused slots in the rack. See the Ordering Information on page 5.

Five Slot, Rear Mount - IC697CHS750
Nine Slot, Rear Mount - IC697CHS790
Nine Slot, Front Mount - IC697CHS791

GFK-0079K
 November 1999

Table 1. Specifications for Standard Racks, IC697CHS750/790/791 †

Number of Slots	5 or 9, plus power supply slot		
Maximum 5 Volt Current	20 amps (100 watt 120/240 VAC or 125 VDC power supply) 11 amps (55 watt 120/240 VAC or 125 VDC power supply) 18 amps (90 watt 24 VDC power supply) 18 amps (90 watt 48 VDC power supply)		
Current Required from I/O Bus	0.5 amps		
I/O References	User configurable without the use of module jumpers or DIP switches.		
Rack Identification	Four jumpers behind rack power supply		
Dimensions	<i>Height</i>	<i>Width</i>	<i>Depth</i>
Nine Slot Rack	11.15" 283mm	19.00" 483mm	7.5" 190mm
Five Slot Rack	11.15" 283mm	12.6" 320mm	7.5" 190mm
	All modules for the IC697 I/O system extend 1.7" (43mm) beyond the front of the rack.		
VME	System designed to support the VME standard C.1		

† Refer to GFK-0867B, or later for product standards and general specifications.

Table 2. Ordering Information

Description	Catalog Number
Rack , Five-Slot, rear mount	IC697CHS750
Rack, Nine-Slot, rear mount	IC697CHS790
Rack , Nine-Slot, front mount	IC697CHS791
Power Supply Cable Kit (includes cable and faceplate for vacant power supply slot)	IC697CBL700
Blank Faceplate Slot Filler (quantity 6)	IC697ACC720
Rack FanAssembly, 120 VAC (optional)	IC697ACC721
Rack FanAssembly, 240 VAC (optional)	IC697ACC724
Rack FanAssembly, 24 VDC (optional)	IC697ACC744

Note: For Conformal Coat option, Low Temperature Testing option, or Severe Vibration option please consult the factory for price and availability. Racks for use in Severe Vibration environments include heavy duty side mount plates.

Power Supply Compatibility With Rack Versions

The **IC697 standalone power supplies** can only be mounted on the IC697 racks having the catalog numbers listed below.

- IC697CHS790D (Nine-Slot, rear mount) and IC697CHS750C (Five-Slot, rear mount)

The catalog numbers for the standalone power supplies affected by this restriction are:

- IC697PWR721 (24 VDC, 90W Power Supply with Power Supply Adapter)
- IC697PWR722 (24 VDC, 90W Power Supply Module)
- IC697PWR731 (125 VDC, 60W Power Supply with Power Supply Adapter)
- IC697PWR732 (125 VDC, 60W Power Supply Module)

All plug-in IC697 power supplies can be installed in any version of the IC697 racks.

GFK-0684G
November 1999

VME Integrator Racks, 17 Slot Front and Rear Mount

Features

- Accepts 3rd Party VME modules which require 0.8" spacing.
- Accepts all IC697 PLC module types.
- Rear mount rack mounts in a 10" (254 mm) deep enclosure.
- Front mount rack mounts in a standard 19" (483 mm) rack.
- Accepts plug-in AC/DC and DC IC697 power supplies, or can use external supply (Power Supply Adaptor module required).
- Provision for two rack operation from single power supply.
- Provision for power supply for high-current configurations.
- Optional accessory kit available for adding J2 backplane or making ribbon cable connections to J2 backplanes.
- Optional fan assembly (for high-power modules).

Functions

The VME Integrator Rack for the IC697 Programmable Logic Controller can be used for 3rd party VME modules and all IC697 CPU and I/O configurations, except redundancy applications. This rack has a 17-slot backplane and is designed to provide easy integration of 3rd party VME modules into an IC697 PLC system. **Integration of 3rd Party VME modules must be in accordance with guidelines which are described in the User's Guide to Integration of 3rd Party VME Modules.**

Backplane connectors are spaced on 0.8 inch centers to accommodate 3rd party VME modules. IC697 modules each use two of these slots. *Standard IC697 racks have slots spaced on 1.6 inch centers for IC697 modules.* VME modules that require 0.8 inch spacing for installation in a rack may not fit in the standard IC697 rack (IC697CHS750/790/791).

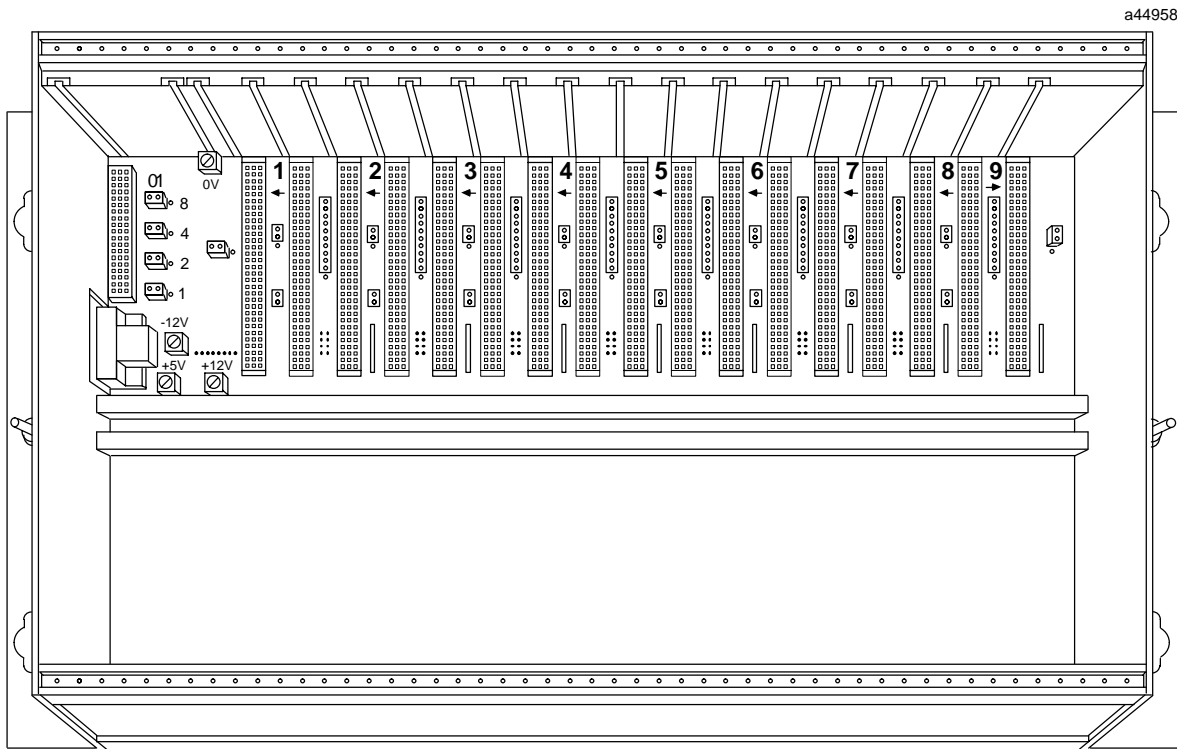

GFK-0684G
November 1999

VME Integrator Racks, 17 Slot Front and Rear Mount

Each rack configuration will accept one power supply in the leftmost module position, and either:

1. seventeen (17) 3rd Party VME modules (with no IC697 modules installed),
2. nine (9) IC697 modules, or
3. a combination of IC697 and 3rd Party VME modules.

The power supply capacity may limit the number of modules in a rack. *No more than three VME modules can be used in a rack with IC697 modules.*

The flexibility of these racks to allow both 3rd party VME and IC697 modules is accomplished through the use of jumpers on the backplane to configure slots. The VME Integrator rack is factory configured to accept standard IC697 modules. Integration of 3rd party VME modules is done by moving these jumpers to different

positions. The exact jumper configuration depends on the requirements of each 3rd Party VME module.

Two racks can be interconnected to share a single power supply for applications having extended I/O requirements. A Power Supply Extension Cable kit (IC697CBL700) is available for such applications. There are also four *power cube* screw connections (+5V, +12V, -12V, 0V) on the backplane. *These connections are not intended for direct connection to a 3rd Party power supply.*

Each rack provides slot sensing for rack-type I/O modules. No jumpers or DIP switches on the I/O modules are required for addressing of these modules. Overall rack dimensions are 11.15" H x 19" W x 7.25" D (283mm x 483mm x 184mm). Slots are 0.8" wide except the power supply slot which is 2.4" wide. The following figures show mounting dimensions for the rear mount (Figure 1) and the front mount (Figure 2) racks.

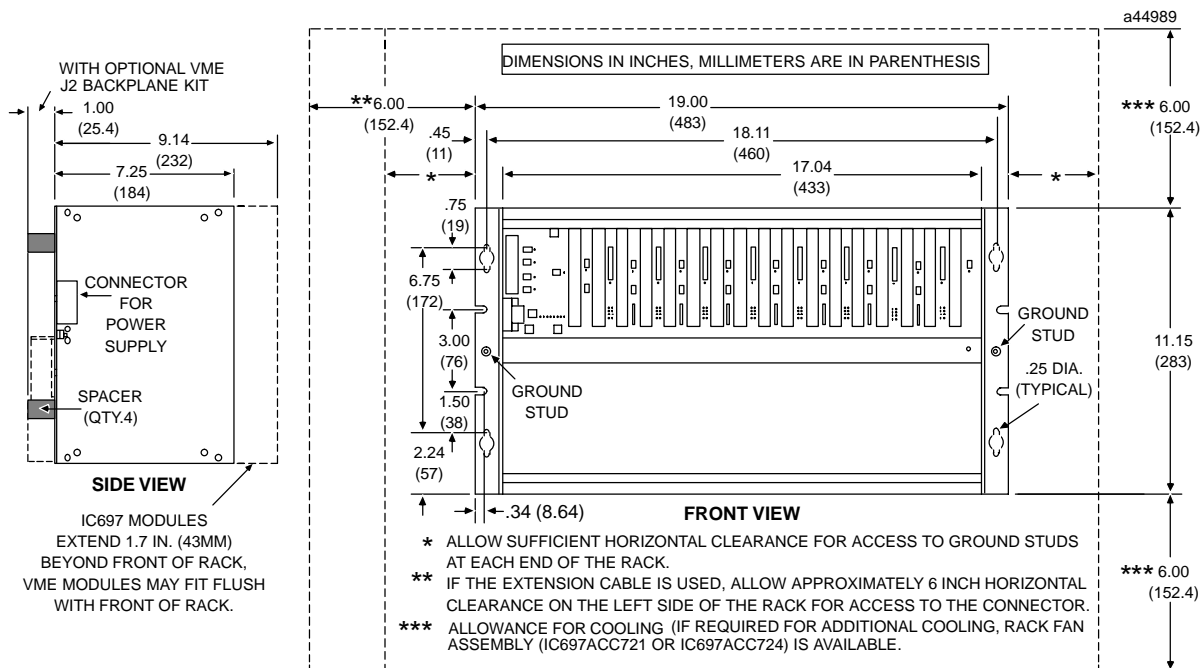

Figure 1. VME Integrator Rack Dimensions for Rack (Rear) Mount

Rack Mounting

The rack must be mounted in the orientation shown above. Sufficient space must be left around the rack as shown in Figure 1 to allow air flow for module cooling. A Rack Fan Assembly (IC697ACC721 or IC697ACC724) is available for installations requiring forced air cooling (see data sheet GFK-0637 for de-

tailed information on the fan assembly). The mounting requirements (either front or rear mount) must be determined according to the application and the proper rack ordered. Mounting flanges are an integral part of rack side panels and are installed at the factory.

VME Integrator Racks, 17 Slot Front and Rear Mount

GFK-0684G
November 1999

These racks accommodate two module types. First, rack-type IC697 high-density I/O modules, which use a detachable field wiring terminal board. Each I/O module will accept up to forty AWG #14 (2.10 mm²) wires. The wire bundle is routed out the bottom of

the terminal board cavity where a cleat is provided for a tie wrap to secure the bundle to the terminal board housing. The second type of modules are VME modules which may have varying methods of connecting to field devices.

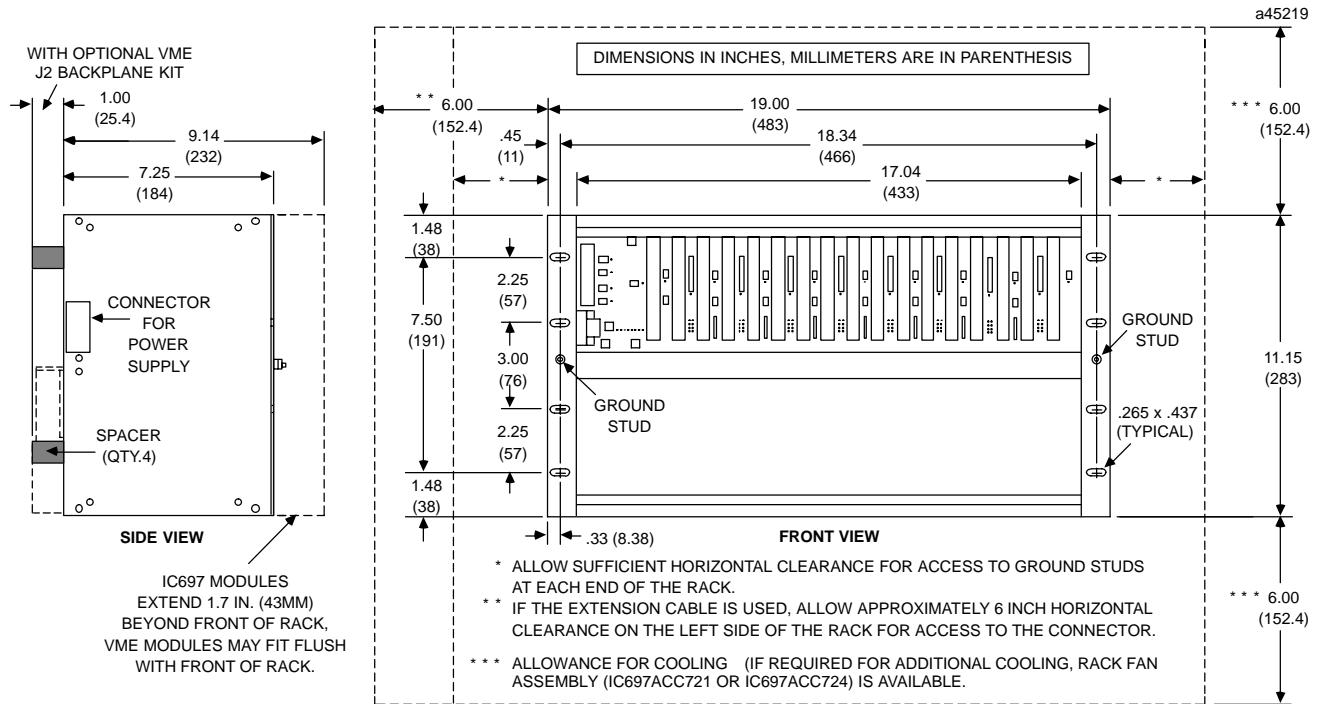

Figure 2. VME Integrator Rack Dimensions for Panel (Front) Mount

Configuring the VME Integrator Rack

A series of jumper positions are located on the backplane near each slot. These jumpers provide for flexibility in the types of modules to be installed, either VME modules in single slots (0.8 inch spacing between centers) or IC697 modules, which require two slots (1.6 inch spacing between centers). IC697 module slots are indicated by a number and an arrow: also these slots are marked 1A through 9A.

Table 1 on page 5 shows the relationship of the slot numbers to the jumper numbers. The functions and signals which are configurable by these jumpers are:

- select a rack ID for multiple rack systems (IC697 feature).
- configure SYSFAIL signal to be enabled or disabled (per slot).
- configure LWORD signal in slot 1 to be inactive.
- configure IRQ1/ - IRQ4/ signals for VME slots 12PL to 19PL.
- configure Bus Grant signals for VME slots 12PL to 19PL.

GFK-0684G
November 1999

VME Integrator Racks, 17 Slot Front and Rear Mount

The following figure is an example of the location of these jumpers on the backplane. The jumpers shown are referenced in the text following the figure.

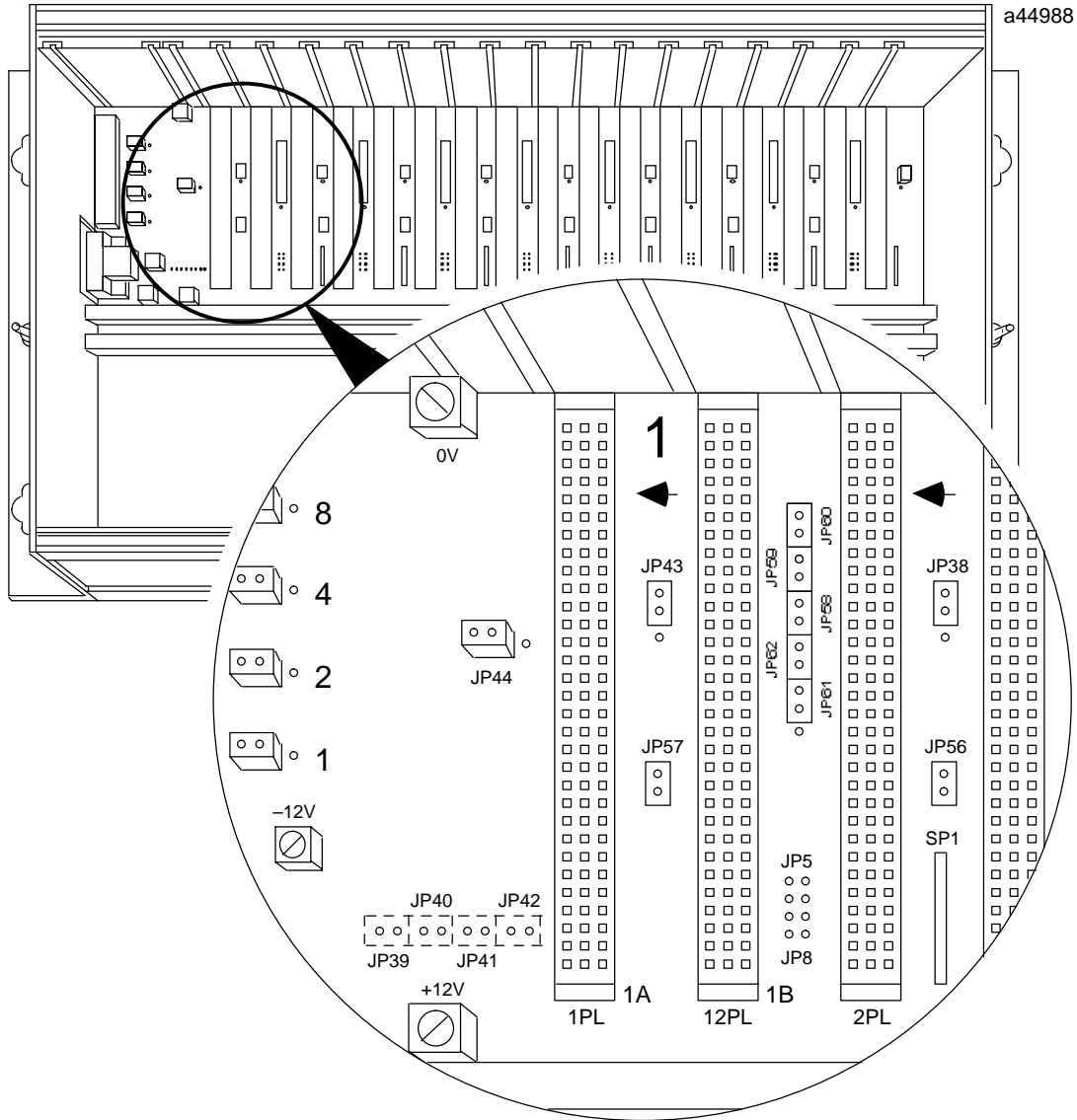

Figure 3. Example of Jumper Locations on Backplane

VME Integrator Racks, 17 Slot Front and Rear Mount

GFK-0684G
November 1999

Default Jumper Configurations

The following table describes the jumper configuration for each of the configurable VME rack signals. The default configuration for each of these signals is shown following the table. Table 2 on the next page lists all of the jumpers and their associated slots.

Table 1. Jumper Descriptions

SignalName or Function	See	ApplicableJumpers	Description
Rack ID Select	-	JP1 to JP4	Selects rack ID number 0 -7, see text for settings (default rack ID = 0)
SYSFAIL/	A	See Table 1 for jumper numbers.	Enabled or disabled for each slot (default = enabled).
LWORD/	B	JP44	Slot 1 only, set to active or inactive (default=inactive).
IRQ1/toIRQ4/(Interrupt lines)	C	See Table 1 for jumper numbers	Select for IC697 module slots 1PL to 9PL. If VME module in slot uses these signals, install jumpers (default = no jumpers).
Bus Grant 0 -3/ and IACK/	D	See Table 1 for jumper numbers	If VME modules are installed that pass daisy chain signals, jumpers must be removed in VME slots 12PL to 19P (default = jumpers).

A configuration selection consists of a jumper plug which is placed over two adjacent pins. In some cases (such as LWORD jumper), this pin is placed over 2 of 3 in-line pins; other selections require the jumper plugs to be present or not be present. Factory default jumper positions are shown below with shaded areas representing a jumper that is present. **The configuration example shown below is for slot 12PL. The physical arrangement for the other connectors is the same, only the jumper numbers (JPxx) are different.**

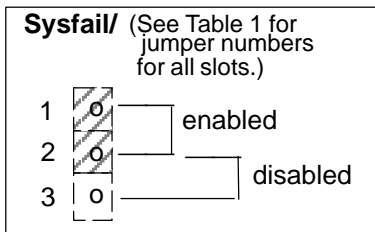

A

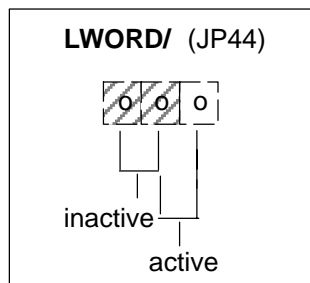

B

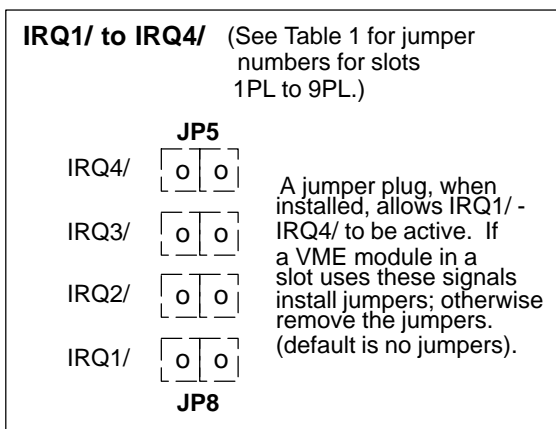

C

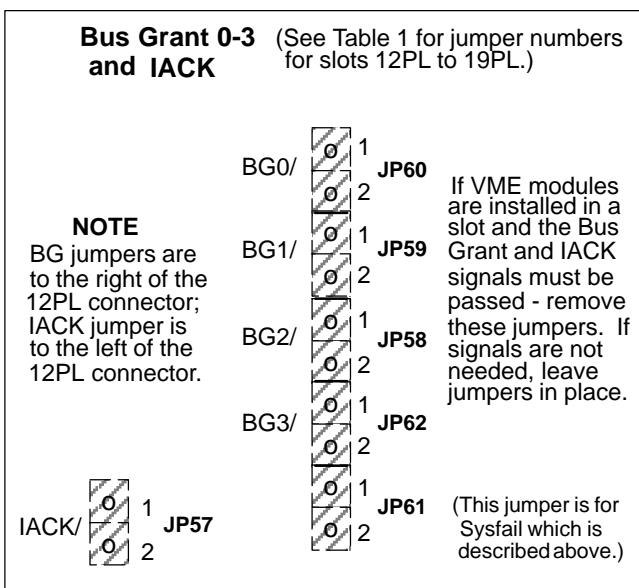

D

* shaded boxes represent default positions

GFK-0684G
November 1999

VME Integrator Racks, 17 Slot Front and Rear Mount

The following table is a list of the slots and jumpers associated with each slot. Multiple jumpers listed in a column under a signal are shown in the same numer-

ical order as they appear on the backplane (that is, left to right or top to bottom).

Table 2. Jumper Location and Function

SlotNumber	Bus Grant 0→3 Jumpers	IACK Jumper	Sysfail Jumper	IRQ1/toIRQ4/ Jumper
1VME-12PL(1B)	JP60,59,58,62	JP57	JP61	-
2VME-13PL(2B)	JP53,54,55,51	JP56	JP52	-
3VME-14PL(3B)	JP66,65,64,68	JP63	JP67	-
4VME-15PL(4B)	JP72,71,70,74	JP69	JP73	-
5VME-16PL(5B)	JP78,77,76,80	JP75	JP79	-
6VME-17PL(6B)	JP84,83,82,86	JP81	JP85	-
7VME-18PL(7B)	JP90,89,88,92	JP87	JP91	-
8VME-19PL(8B)	JP96,95,94,98	JP93	JP97	-
1GEF-1PL(1A)	-	-	JP43	JP39,40,41,42
2GEF-2PL(2A)	-	-	JP38	JP8,7,6,5
3GEF-3PL(3A)	-	-	JP99	JP12,11,10,9
4GEF-4PL(4A)	-	-	JP45	JP16,15,14,13
5GEF-5PL(5A)	-	-	JP46	JP20,19,18,17
6GEF-6PL(6A)	-	-	JP47	JP24,23,22,21
7GEF-7PL(7A)	-	-	JP48	JP28,27,26,25
8GEF-8PL(8A)	-	-	JP49	JP32,31,30,29
9GEF-9PL(9A)	-	-	JP50	JP36,35,34,33

There are three basic configurations of modules that can be accommodated by the VME Integrator rack: (1) Standard (IC697 modules only), (2) IC697 controller and IC697 modules and/or 3rd party VME modules, or (3) 3rd party VME modules only. Refer to Table 2 for jumper numbers and their functions.

(1) Standard Configuration

This configuration consists of an IC697 CPU or Bus Receiver in slot 1PL and IC697 modules in the remaining applicable slots (2PL to 9PL).

Note

Do not install IC697 modules in VME slots 12PL to 19PL.

Standard Configuration Jumper Positions

Refer to Figure 2 which is an example of jumper positions and numbers per slot.

- JP1 through JP4 (rack ID jumpers) jumpered to the proper position for Rack ID, where applicable.
- JP43 remains in its default position (as shipped from factory). This allows the SYSFAIL signal to be activated by the IC697 CPU.
- JP44 remains in its default position. This jumpers the LWORD signal in slot 1 to be inactive allowing only 16-bit wide data transfers.
- All other jumpers remain in their factory set default positions.

(2) IC697/VME Configuration

This configuration consists of an IC697 CPU or Bus Receiver module in slot 1P and a combination of IC697 modules and 3rd party VME modules in the remaining slots. IC697 modules can be placed in slots 2PL to 9PL

VME Integrator Racks, 17 Slot Front and Rear Mount

GFK-0684G
November 1999

only. 3rd party VME modules can use the VME slots 12PL to 19PL and slots 2PL to 9PL. Note that all slots have a jumper that allows you to disable the SYFAIL/signal to that slot by removing the appropriate jumper.

Note

Integration of 3rd Party modules must be in accordance with guidelines described in the *User's Guide to Integration of 3rd Party VME Modules*.

IC697/VME Jumper Positions

- JP 1 through JP4 (rack ID jumpers) jumpered to the proper position for Rack ID.
- JP43 remains in its default position (as shipped from factory). This allows the SYSFAIL signal to be activated by the IC697 CPU (SYSFAIL required by IC697I/O modules).
- JP44 remains in its default position. This jumpers the LWORD signal in slot 1 to inactive (for IC697 modules) allowing only 16-bit wide data transfers.
- VME modules can be installed in either the IC697 module slots (2PL to 9PL) or in the VME slots (12PL to 19PL).
- If VME modules are installed in the IC697 module slots (2PL to 9PL) that use the signals IRQ1/ - IRQ4/, then you must install up to four jumpers, as appropriate, in positions that are located to the immediate left of the IC697 slots in use.
- If the VME modules are installed in VME slots (12PL to 19PL), and the board passes the Bus Grant and IACK signals, you must remove five jumpers for each slot being used. *Leave these jumpers in if the board does not pass the Bus Grant and IACK daisy chain signals.* These jumpers are the top four to the immediate right of the slot being used and the lower (of two jumpers) to the immediate left of the slot being used.

(3) VME Configuration

This configuration consists of a 3rd party Controller in slot 1PL and 3rd party VME modules in the remaining slots (2PL to 9PL and 12PL to 19PL). Note that each slot has a jumper that allows the SYFAIL/signal to be disabled to that slot since all VME modules may not require access to that signal.

VME Jumper Positions

- To configure slot 1 for a 3rd party controller, five jumpers must be moved. There are four jumpers behind the power supply (JP1 to JP4) that must be moved to positions JP39 to JP42 and jumper JP44 must be moved from its default position to the right.
- If VME modules are installed in the IC697 module slots (2PL to 9PL) and they use the IRQ1/ - IRQ4/ signals, then you must install four jumpers in the positions that are located to the immediate left of the IC697 module slots in use.
- If the VME modules are installed in VME slots (12PL to 19PL), and the board passes the Bus Grant and IACK signals, you must remove five jumpers for each slot being used. *Leave these jumpers in if the board does not pass the Bus Grant and IACK daisy chain signals.* These jumpers are the top four to the immediate right of the slot being used and the lower (of two jumpers) to the immediate left of the slot being used.

Power Supply Extension Cable

For many applications, one power supply is sufficient for the power requirements of two racks. This two-rack operation from a single power supply can be implemented if only +5 volt power (± 12 volts not supplied through Power Supply Extension cable) of 5.2 amperes or less is required in the second rack.

A 3-foot Power Supply Extension cable is available (see Ordering Information on the last page of this data sheet) which provides the necessary interconnection. In addition to + 5 volt power, the extension cable includes power sequencing signals necessary for proper system operation.

The Power Supply Extension cable attaches to a 9-pin D type connector located on the backplane. Access to the connector is through a hole in the left side of the rack as shown in the outline drawing (Figures 1 and 2). Adequate clearance (approximately 6 inches) must be provided on the left side of the rack for access to the connector.

This connector can also be used to provide power to a user installed 3rd party J2 backplane. An option kit (IC697ACC715) is available for installing a J2 backplane or making ribbon cable connections. Maximum power that can be supplied to the J2 backplane is 5 VDC at 5.2 amps.

GFK-0684G
November 1999

VME Integrator Racks, 17 Slot Front and Rear Mount

The Power Supply Extension cable must be secured before power is applied. It must not be disconnected during system operation.

Slot Addressing

The IC697 PLC system allows user configuration of I/O point references for modules in a rack without the need for board address DIP switches or jumpers. The address structure is described below. Configuration is done with the MS-DOS® or Windows® programming software configurator function. For more information on configuration, see the *Programming Software User's Manual*.

Note

In order to configure slots 12PL to 19PL, you must have release 4.01 or later of MS-DOS programming software.

Rack Number

Multiple racks in a system must be assigned a rack number from 0 to 7; the CPU rack is always Rack 0. The PLC determines the number of each rack in the system from four binary-encoded configurable jumpers on the rack's backplane.

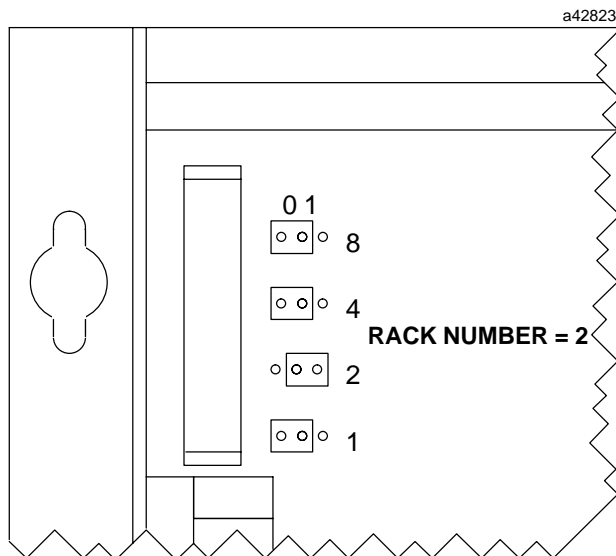

Figure 4. Rack Number Jumpers

These jumpers are located on the backplane directly behind the power supply, which must be removed to gain access to the jumpers.

To set the rack number, move the jumpers corresponding to 1, 2, 4, and 8 bits to either the 0 or 1 position. The sum of the digits in the 1 position equals the desired rack number. For example, rack number 5 would have the 1 and 4 bit jumpers in the 1 position and the 2 and 8 bit jumpers in the 0 position.

Shield Ground

The bottom rail of the rack is used for module shield grounding. Some IC697 I/O modules have a ground clip that contacts the conductive bottom rail when the module is fully inserted. Shield connections in the user connectors are routed to this ground clip through conductors on the module.

Safety Ground

The ground lug on either side of the rack must be connected to earth ground with not less than an AWG #12 (3.33 mm²) wire. The ground lugs are #8-32.

Warning

If the ground lug is not connected to earth ground, the rack is not grounded. The rack must be grounded to minimize electrical shock hazard which may result in severe personal injury.

System Noise Immunity

Three easy steps must be taken to properly ground the IC697 PLC system to reduce the possibility of errors due to electrical noise.

1. Make sure that the power supply mounting screws, especially the bottom two, are properly secured.
2. The GND terminal on the power supply must be connected to the GND terminal on either side of the rack using AWG #12 (3.33 mm²) wire. Use of a ring terminal and star washer is recommended.
3. The GND terminal on the rack must be connected to a good earth ground.

© MS-DOS and Windows are registered trademarks of Microsoft Corporation.

VME Integrator Racks, 17 Slot Front and Rear MountGFK-0684G
November 1999**Module Retention**

IC697 I/O modules have molded latches that automatically snap onto the upper and lower rails of the rack when the module is fully inserted. **3rd party VME modules do not have these latches.** Optionally, M2.5x8 screws may be used to secure the modules to the rack for high vibration applications.

To remove an IC697 module, first remove the field half of the terminal board (if it is an I/O module), then grasp the top and bottom of the module to depress the latch releases while pulling the module out. For more detailed information on removing I/O terminal boards, refer to the applicable *Programmable Controller Installation Manual* or individual data sheets for I/O modules.

Warning

Do not remove (or insert) modules when either the IC697 power supply or any externally-connected power sources are on. Hazardous voltages may exist. Personal injury, damage to the module or unpredictable operation of the device or process being controlled may result.

If M2.5x8 screws have been used to secure modules to the rack, remove the screws before removing the modules. A blank faceplate is available to cover two consecutive unused slots in the rack.

Rack Fan Assembly

An optional Rack Fan Assembly is available in three versions for installation on the bottom of the rack for additional cooling if forced air cooling is required when a number of high-power VME modules are installed in the rack and heat build-up could be a problem. The Rack Fan Assemblies are:

- IC697ACC721 for 120 VAC power source
- IC697ACC724 for 240 VAC power source
- IC697ACC744 for 24 VDC power source

The fans have a low noise level and are assembled using ball bearings for extended life.

It is recommended that the fans be wired to the same source of power as the IC697 PLC. This will ensure that the fans are running when the PLC is active.

AC Rack Fan Assemblies (IC697ACC721/724): The three fans are wired in parallel using a cable assembly (supplied with the fan assembly) that plugs into the three fan wiring connectors. When the cable assembly is installed, the fan on the left (looking at front of rack) will have a three foot lead with stripped ends for connecting to the applicable 120 or 240 VAC power source.

24 VDC Rack Fan Assembly (IC697ACC744): The three fans each have a pair of 12" (310 mm), 24 AWG leads. Connect these leads in parallel, with all Red leads connected to +24 VDC, and all Black leads connected to 24 VDC Common. Use wire ties to fasten leads down.

The following illustration shows the position of the fan assembly mounted on a rack. Note that it is mounted on the bottom of the rack with air flow from the bottom towards the top of the rack. For detailed specifications and installation instructions, refer to GFK-0637, which is the data sheet for the *Rack Fan Assembly*.

GFK-0684G
November 1999

VME Integrator Racks, 17 Slot Front and Rear Mount

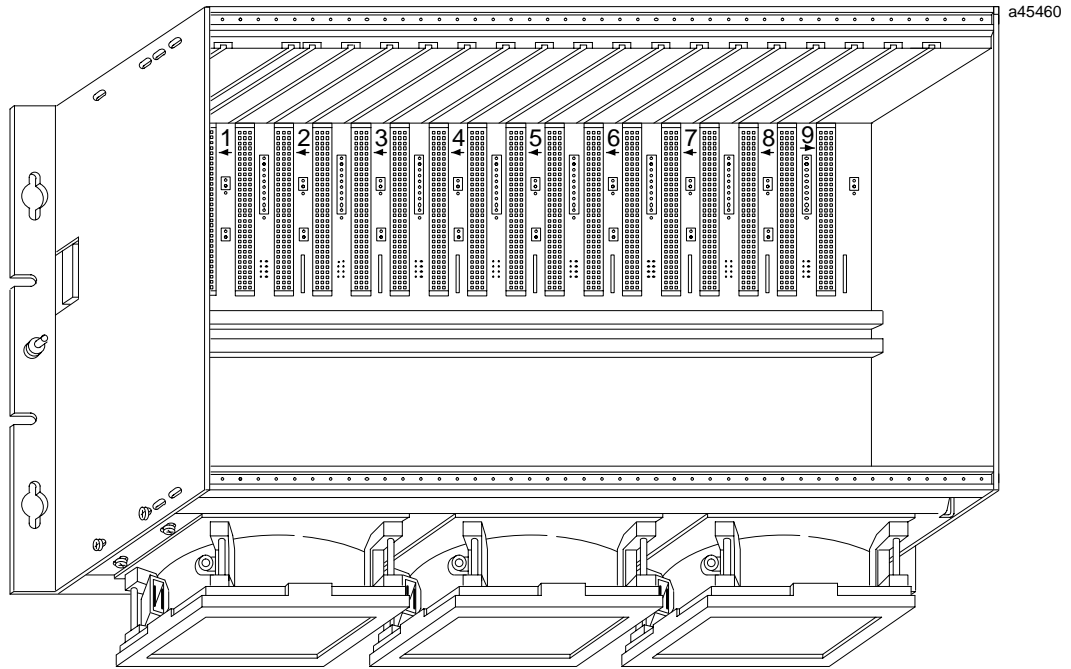

Figure 5. Typical Fan Assembly Mounted on VME Integrator Rack (AC Type Fan Assembly Shown)

Table 3. VME Integrator Rack Specifications †

Number of Slots:	17 on 0.8" centers plus power supply slot												
Maximum 5 Volt Current (from standard IC697 power supplies):	20 amps (100 watt 120/240 VAC or 125 VDC power supply) 11 amps (55 watt 120/240 VAC or 125 VDC power supply) 18 amps (90 watt 24 VDC power supply) 18 amps (90 watt 48 VDC power supply)												
Maximum current (user supplied (not IC697) Power Supply slot J1 only)	3.3 amps (+ 5 VDC) 1.1 amps (± 12 VDC)												
I/O References: Rack Identification: VME/IC697 Slot Configuration:	User configurable with IC641 programming software configurator software Four jumpers (JP1 - JP4) behind rack power supply Configure jumpers on backplane (refer to text)												
Dimensions:	<table border="0"> <tr> <td><i>Height</i></td> <td><i>Width</i></td> <td><i>Depth</i></td> <td><i>(Note that all IC697 modules extend 1.7" (43 mm) beyond front of rack.)</i></td> </tr> <tr> <td>11.15"</td> <td>19.00"</td> <td>7.5"</td> <td></td> </tr> <tr> <td>283mm</td> <td>483mm</td> <td>190mm</td> <td></td> </tr> </table>	<i>Height</i>	<i>Width</i>	<i>Depth</i>	<i>(Note that all IC697 modules extend 1.7" (43 mm) beyond front of rack.)</i>	11.15"	19.00"	7.5"		283mm	483mm	190mm	
<i>Height</i>	<i>Width</i>	<i>Depth</i>	<i>(Note that all IC697 modules extend 1.7" (43 mm) beyond front of rack.)</i>										
11.15"	19.00"	7.5"											
283mm	483mm	190mm											
VME	System designed to support VME standard C.1												

† Refer to GFK-0867B, or later for product standards and general specifications.

VME Integrator Racks, 17 Slot Front and Rear Mount

 GFK-0684G
 November 1999

Table 4. Ordering Information

Description	CatalogNumber
VME Integrator Rack - 17 slots, rear mount	IC697CHS782
VME Integrator Rack - 17 slots, front mount	IC697CHS783
Power Supply Cable Kit (includes cable and faceplate for empty power supply slot)	IC697CBL700
Option Kit for J2 backplane installation (backplane not included)	IC697ACC715
Rack Fan Assembly (optional), 120 VAC	IC697ACC721
Rack Fan Assembly (optional), 240 VAC	IC697ACC724
Rack Fan Assembly (optional), 24 VDC	IC697ACC744

Note: For Conformal Coat option, or Low Temperature Testing option please consult the factory for price and availability.

Rack Fan Assembly

Features

- Provides additional rack cooling
- Three fans per assembly
- Easy installation
- 120 VAC, 240 VAC, or 24 VDC models
- Used with IC697 standard nine-slot racks and 17-slot VME Integrator racks.
- Includes optional mounting brackets for earlier versions of IC697 racks

Functions

The **Rack Fan Assembly** is an easily installed accessory for use with IC697 standard nine-slot racks and VME Integrator 17-slot racks. The fan assembly consists of three fans. This fan assembly provides additional rack cooling for installations where heat buildup could be a problem. The fans have a low noise level and use ball bearings for extended life.

It is recommended that the fans be wired to the same source of power as the IC697 PLC. This will ensure that the fans are running when the PLC is active.

AC Rack Fan Assemblies (IC697ACC721/724): The three fans are wired in parallel using a cable assembly (supplied with the fan assembly) that plugs into the three fan wiring connectors (see Figure 1). When the cable assembly is installed, the fan on the left (looking at front of rack) will have a three foot lead with stripped ends for connecting to the applicable 120 or 240 VAC power source.

24 VDC Rack Fan Assembly (IC697ACC744): The three fans each have a pair of 12" (310 mm), 24 AWG leads (see Figure 6). Connect these leads in parallel, with all Red leads connected to +24 VDC, and all Black leads connected to 24 VDC Common. Use wire ties to fasten leads down.

The rack fan assembly comes as a kit which includes a fan assembly, eight screws and two optional mounting brackets. The two optional mounting brackets are required when mounting the fan assembly on earlier versions of racks. New rack assemblies can be identified by *metal grilles* on top and bottom of the rack. **Earlier versions of IC697 racks do not have metal grilles.**

Rack and Fan Assembly Compatibility

The current version of the Rack Fan Assembly (IC697ACC721B, 724B, and 744) is compatible with IC697 racks having the following catalog numbers:

- IC697CHS782A or later versions
- IC697CHS783A or later versions
- IC697CHS790D or later versions
- IC697CHS791D or later versions

Note

This version of the Rack Fan Assembly is compatible with racks built to conform to shock and high vibration specifications. These high vibration racks have an SV suffix added to the existing rack suffix. For example, IC697CHS790ESV denotes that the rack is a high vibration rack. All rack mounting dimensions and instructions in this data sheet also apply to high vibration racks.

The previous version of the fan assembly (IC697ACC721A and 724A) is compatible with the following IC697 racks.

- IC697CHS782A, B only
- IC697CHS783A, B only
- IC697CHS790D only
- IC697CHS791D only

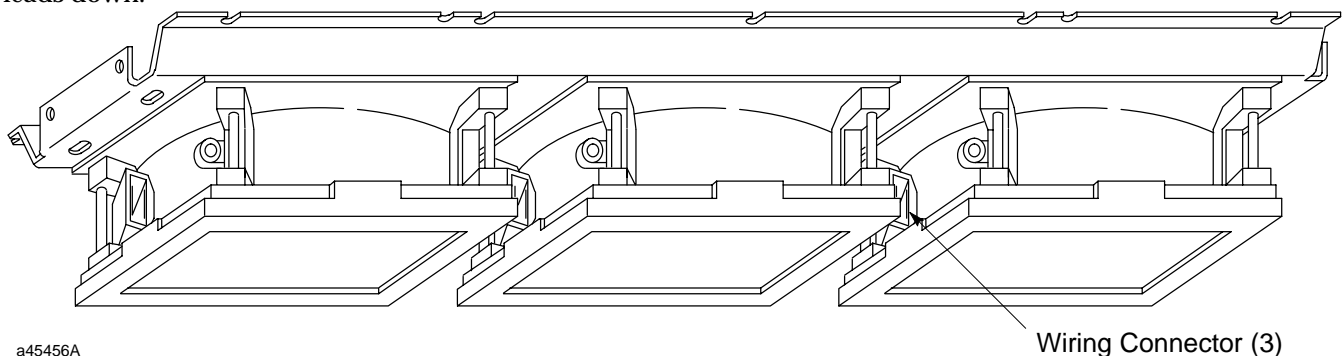

Figure 1. AC Rack Fan Assemblies IC697ACC721/724

GFK-0637E
October 1999

Rack Fan Assembly

The following illustration shows the position of the fan assembly when it is mounted on a rack. Note that it is

mounted on the bottom of the rack with air flow from the bottom towards the top of the rack.

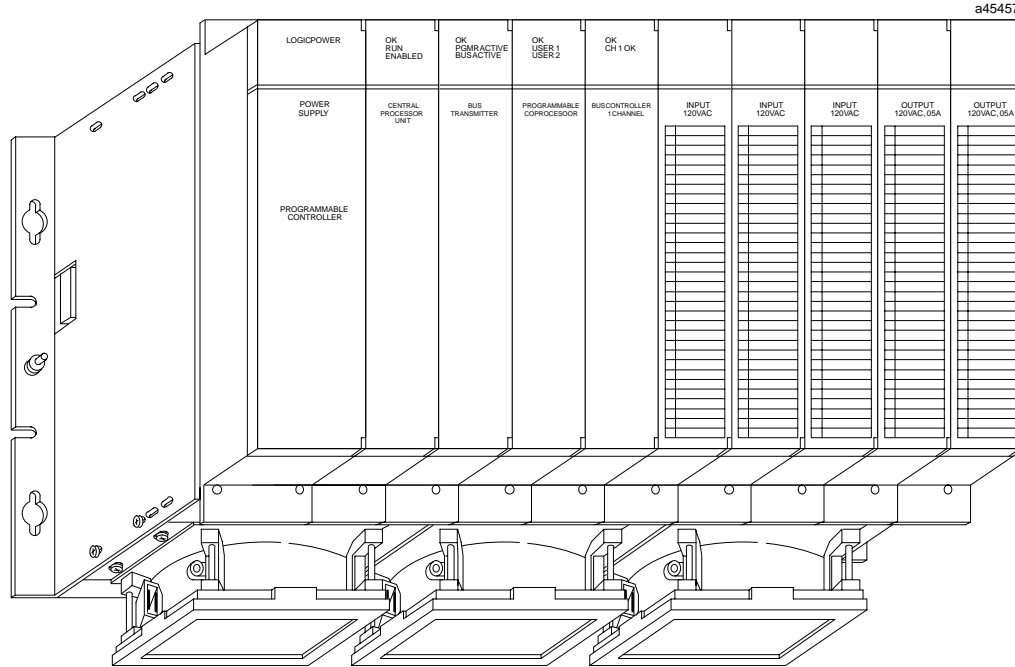

Figure 2. Typical Fan Assembly Mounting (AC Type Fan Assembly Shown)

Installing the Fan Assembly

To install the fan assembly, use the following instructions (refer to Figure 3). *Installation of the fan*

assembly is easy; the only tool you need to attach the fan assembly to the rack is a #2 Phillips screwdriver.

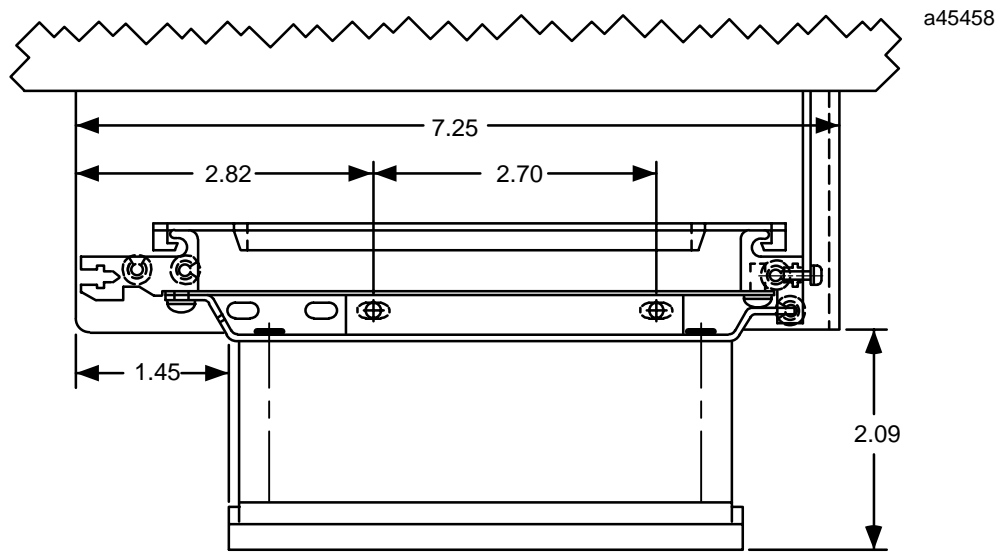

Figure 3. Fan Assembly Dimensions for Mounting

Rack Fan Assembly

GFK-0637E
October 1999

Mounting Fan Assembly on Racks

1. Position the fan assembly on the bottom of the rack and slide the flange on the rear of the fan assembly (flange **without** slots) under the lip of the rear rail on the rack.
2. While doing this, align the two holes in each end of the fan assembly with the holes in the rack side plates.
3. Install two screws in each end and secure the fan assembly by tightening the screws to 10–12 in.-lbs.
4. There are two additional screws that must be installed in the front rail. Install these screws and tighten to 10–12 in.-lbs.

Mounting Fan Assembly on Earlier Versions of Racks (with Optional Bracket)

1. Slide the flange on the two optional brackets under the lip of the front and rear rails on the rack. The bracket tabs must face towards the rack side plates. Slide the brackets out towards the rack side plates.
2. Secure the brackets by aligning the two bracket holes with the two edge slots in each side plate.
3. Install two screws at each end and secure the bracket by tightening the screws to 10–12 in.-lbs.
4. Attach the fan assembly to the optional brackets with four screws; two at each end of the fan assembly. Secure by tightening the screws to 10–12 in.-lbs.

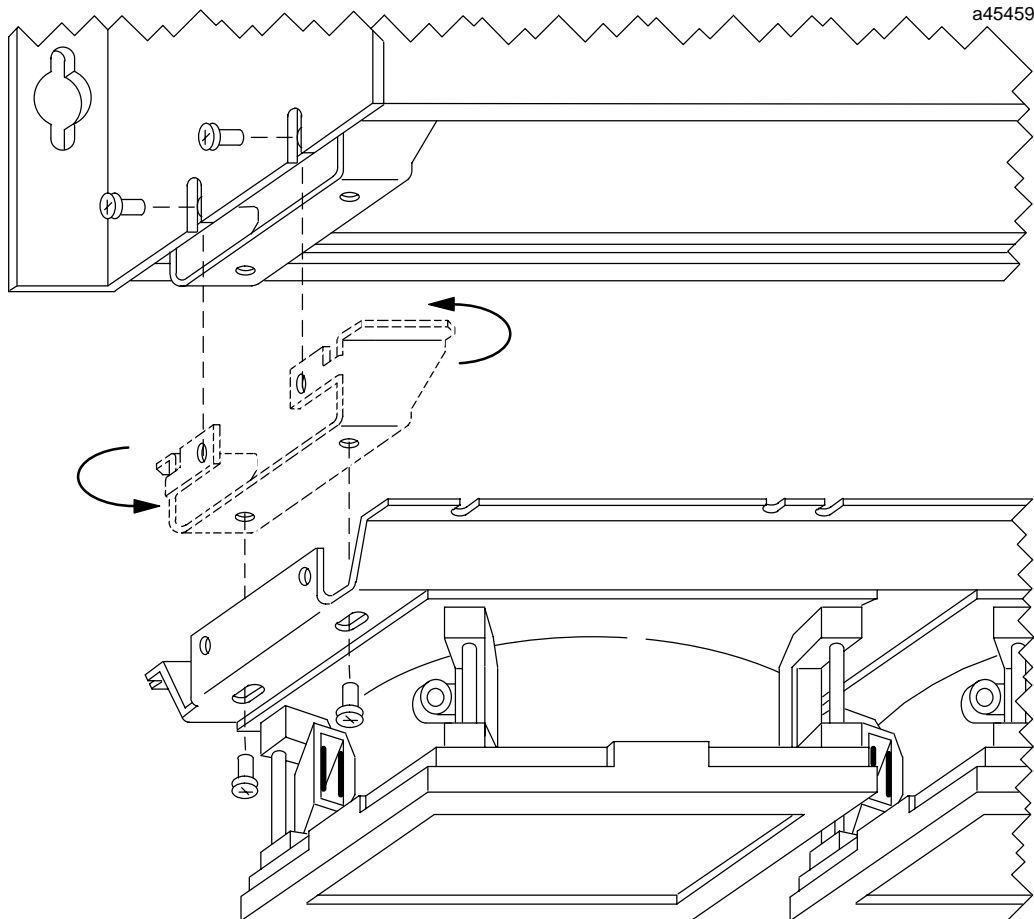

Figure 4. Mounting Details for Fan Assembly (AC Type Shown) and Optional Mounting Bracket

GFK-0637E
October 1999

Rack Fan Assembly

Changing the Filter

Each fan has a polyurethane filter which can be removed, and cleaned or replaced as needed. Removing a filter is easy, simply lift the tabs located on all four sides of the plastic retainer. Remove the filter and either clean it or replace it with a new filter.

To replace a retainer, align the retainer with the filter assembly and snap the retainer back in place. Details of the filter assembly are shown in the following figure.

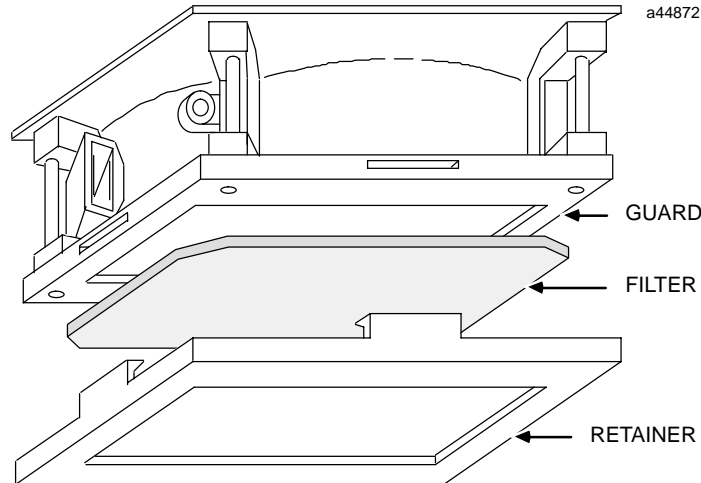

Figure 5. Filter Guard Assembly (AC Type Fan Shown)

Wiring 24 VDC Fans

On the 24 VDC Fan Assembly, IC697ACC744, each fan has a pair of 24 gauge, 12" (310 mm) long leads. Connect

all the Red leads to +24 VDC, and all the Black leads to 24 VDC common.

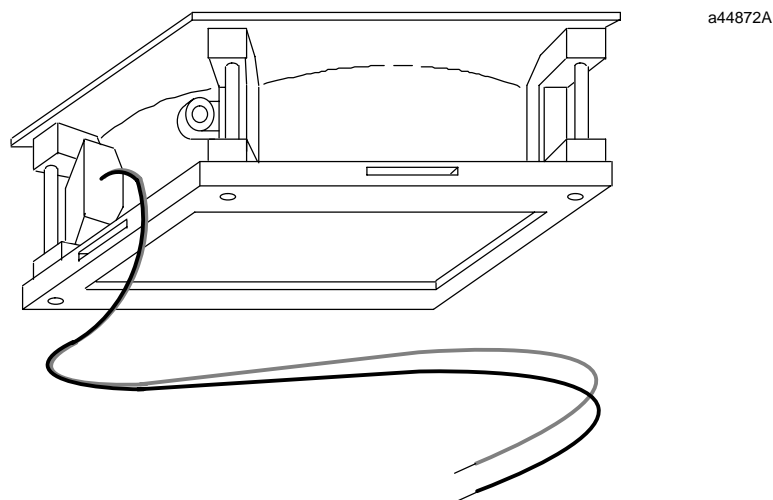

Figure 6. Wire Lead Detail for Fans in the IC697ACC744 24 VDC Rack Fan Assembly

Rack Fan Assembly

GFK-0637E
October 1999

Table 1. Specifications for IC697ACC721/724/744 †

Operating Voltage:	120 VAC, 50/60Hz (IC697ACC721) 240 VAC, 50/60Hz (IC697ACC724) 24 VDC (IC697ACC724)
Input Power (each fan):	15 to 17 watts at 120 VAC 16 to 17 watts at 240 VAC 6.7 watts at 24 VDC
Line Amps (each fan):	0.18 to 0.20 amps at 120 VAC 0.09 to .010 amps at 240 VAC 0.28 amps at 24 VDC
Locked Rotor Amps (each fan):	0.24 to 0.26 amps at 120 VAC 0.12 to 0.14 amps at 240 VAC 0.70 amps at 24 VDC
Operating Temperature:	-28 ° to +70°C (-18.4 ° to +158°F)
Nominal Air Flow (without filter):	@120 or 240 VAC, 60 Hz: 108 CFM (each fan)
Nominal Air Flow (with filter):	@120 or 240 VAC, 60 Hz: 71 CFM (each fan)
Weight of Fan Assembly:	5.94 pounds (2.69 kg)
MTBF for each fan:	@ 40°C (104°F) >80,000 Hours (manufacturers specification) @ 60°C (140°F) >50,000 Hours (manufacturers specification)
Filter Assembly	
Retainer and Guard:	UL94V-0 Plastic
Filter Type:	Polyurethane Foam, 30 PPI (Pores Per Inch)

† Refer to GFK-0867B, or later for product standards and general specifications.

Table 2. Ordering Information

Description	Catalog Number
Rack Fan Assembly, 120 VAC	IC697ACC721
Rack Fan Assembly, 240 VAC	IC697ACC724
Rack Fan Assembly, 24 VDC	IC697ACC744
Replacement Filter Element, Comair Rotron	554146 (5 pack)

The Rack Fan Assembly comes as a kit which includes a fan assembly, two optional mounting brackets, and eight screws.

Power Supplies

IC697PWR724/CE697PWR724

GFK-1047F
August 1997

24 VDC, 90W Power Supply Module

Features

- Operation from 24 VDC
- Three output voltages, 90 watts total
 - +5 VDC output up to 18 amps
 - +12 VDC output up to 1.5 amps
 - 12 VDC output up to 1 amp
- Slide-in rack mount construction
- Electronic short circuit overcurrent protection provided on 5 volt bus
- Two rack operation from a single power supply

Functions

The **90 Watt Power Supply Module** is a rack-mounted

unit that plugs directly into a 48-pin backplane-mounted connector in the leftmost slot in the rack. It provides +5 volt, +12 volt and -12 volt power, and logic level sequencing signals to the backplane.

This power supply can be used either in a single rack application, or can also be used to provide power to a second rack if the total load is within the supply rating. Interconnection to the second rack is through a pre-wired cable (IC697CBL700).

The power supply output will ride through a 10 msec total loss of input power at full load. Protection is provided for overcurrent and overvoltage fault conditions.

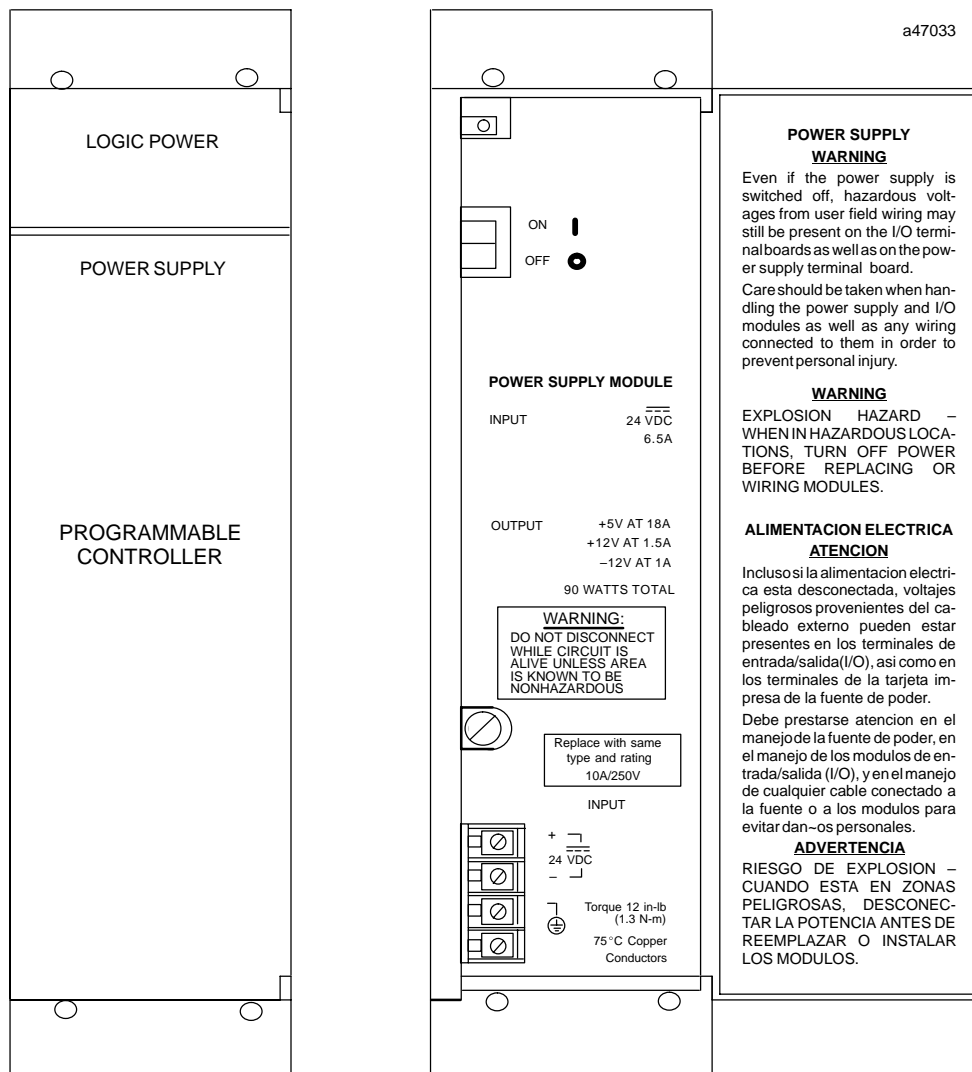

GFK-1047F
August 1997

24 VDC, 90W Power Supply Module

Operation of the Power Supply

This Power Supply Module operates from a 24 VDC nominal line. The power supply can accept an input voltage range of from 18 to 32 VDC.

Overvoltage Protection

The power supply includes an electronic overvoltage protection circuit. This circuit will clamp the output if the 5 V bus exceeds 6.7 volts. External overvoltage on the output will not cause the power supply fuse to open. However, if an internal fault in the power supply caused the overvoltage condition, the fuse may open. Replace this fuse with a 10 amp, 250 volt 5x20 mm fuse.

Overcurrent Protection

The power supply provides an electronic overcurrent limit for each of the three outputs (26 amps for +5 volts, 4 amps for +12 volts, and 2 amps for -12 volts (all maximum)). If the maximum current rating is exceeded, the output voltage will drop.

It will remain in that state until the load is either removed or reduced. A current overload (including a short circuit condition) will not cause the fuse to open.

Temperature Derating

For operation at ambient temperatures that exceed 50°C (122°F), maximum output power must be derated as shown in the derating curve.

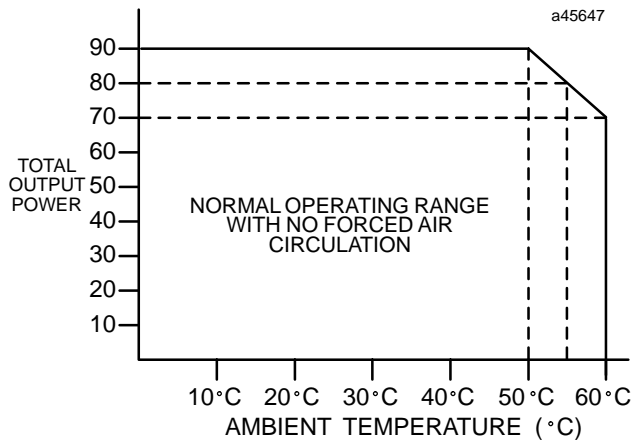

Figure 7. Output Power Derating Curve

Dual Rack Operation

A single power supply can provide power for two racks under the following conditions:

- Only 5 volt power is required in the second rack, and the total power required by both racks is within the capability of the supply.
- The current drawn by the second rack is less than 5.2 amperes.
- The two racks must be mounted in close proximity as limited by the available 3-foot connecting cable.

The connecting cable used for dual rack operation is listed in Table 2, *Ordering Information*. This cable carries the +5 volt power bus as well as the power sequencing signals. It uses a 9-pin D-type connector which connects directly to the backplane through an opening in the rack frame. Note that the cable carries power and power sequencing signals only. Inter-rack communication and bus interface modules must be provided separately. See the applicable *Programmable Controller Installation Manual* for application information.

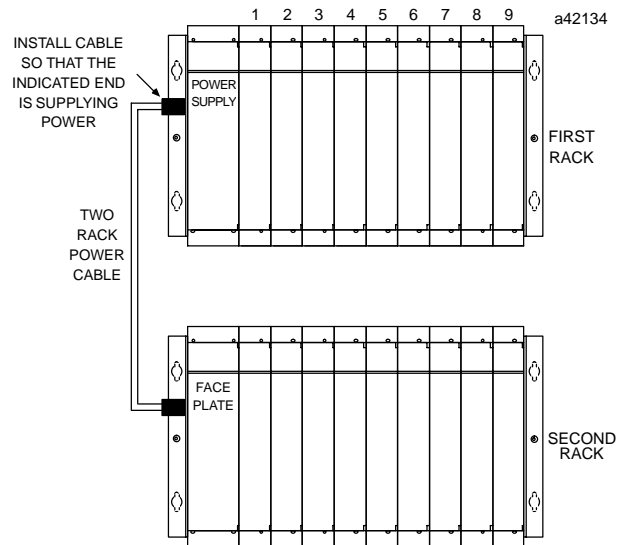

Figure 8. Dual Rack Configuration

Timing Diagram

The timing diagram below shows the relationship of the dc input power to the dc outputs and to the two system signals generated by the power supply: *ACFAIL* and *SYS-RESET*. The *5VSTBY* output may be used for user battery backup schemes as shown.

On application of power, the *ACFAIL* signal goes false soon after the 5 volt bus is within specification. The *sys-*

24 VDC, 90W Power Supply Module

GFK-1047F
August 1997

tem is held in the Reset state by SYSRESET for at least 200 milliseconds after 5 volt power is available (during this time, outputs are forced off).

If input power is interrupted, the 5 volt bus will remain within specifications for at least 10 ms. The system is then given an additional 5 milliseconds to complete an orderly shutdown before SYSRESET stops all processing.

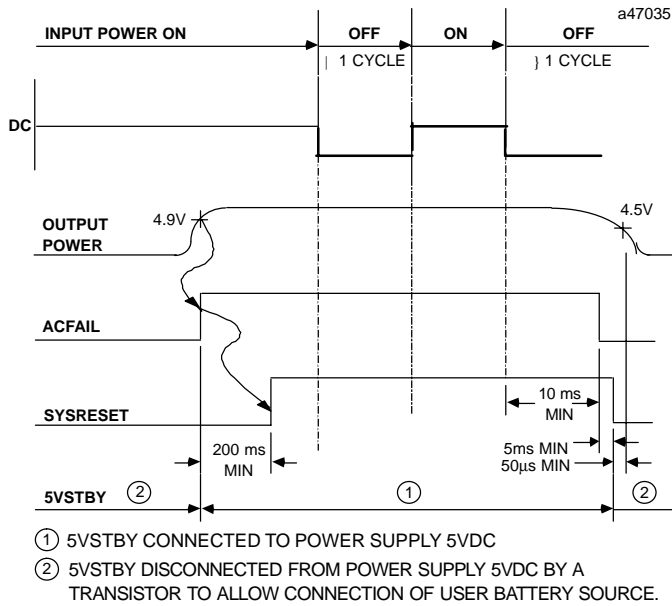

- ① 5VSTBY CONNECTED TO POWER SUPPLY 5VDC
- ② 5VSTBY DISCONNECTED FROM POWER SUPPLY 5VDC BY A TRANSISTOR TO ALLOW CONNECTION OF USER BATTERY SOURCE.

Figure 9. Timing Diagram for 24 VDC Power Supply

Note

Input power interruptions that exceed the power supply ride through time (10 milliseconds minimum) will result in a complete power down/power up cycle of ACFAIL and SYSRESET.

Inrush

When input voltage is initially applied, internal energy storage elements will draw a surge current from the 24 VDC input power source which can be in the range of 100 amps depending on the installation and power source impedance characteristics. Standard best practices should be used for installations where minimizing inrush current is a consideration. Typical best practices include providing local energy storage which can be either system batteries or capacitors at each power supply input, and minimizing resistance from the storage elements to prevent significant voltage drop during the initial energy transfer.

Note that this inrush *only occurs* during the initial application of input voltage to the power supply. Turning the power switch On and OFF *does not* disconnect pow-

er from internal energy storage elements, and therefore does not require inrush energy from the power source.

Mounting

The Power Supply is a plug-in module which is secured to the rack with four M 2.5 screws (included). Be certain that these screws are tightened both to secure the power supply to the rack, and to assure proper power supply-to-rack grounding.

Power Supply Door

The power supply door can be opened by grasping the upper left corner of the door with your right thumb or a fingernail and gently pulling the door towards you. Use care when opening the door since pulling from the bottom can cause the hinge or the door to break.

Input Voltage and Grounding

The power input terminal board provides two terminals for connecting 24 VDC power and an additional terminal for system and noise ground. Power input connections should be made with copper AWG #16 (1.33 mm²) through AWG #12 (3.31 mm²) wire rated for 75°C (167°F).

Each terminal can accept solid or stranded wires, but the wires into any given terminal should be the same type and size.

It is recommended that the GND terminal on the power supply be connected to the GND terminal on the rack and to earth using copper AWG #12 (3.3 mm²) wire rated for 75°C (167°F) and a ring terminal to ensure adequate grounding. Use of a nut and star washer for each wire on the GND lug is recommended.

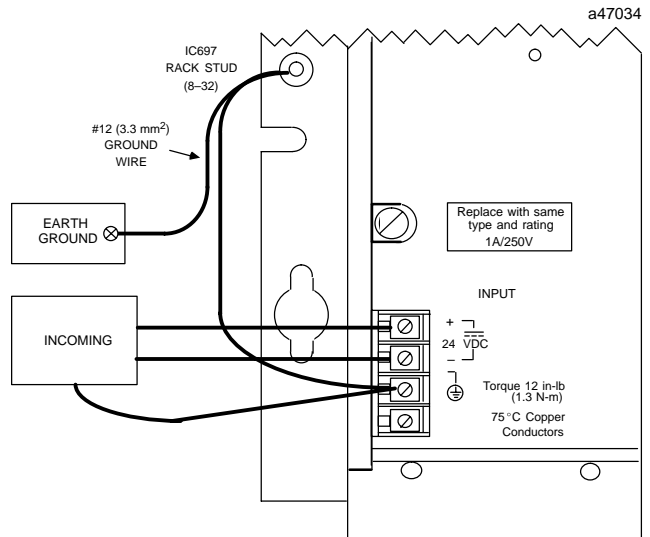

Figure 10. Input Wiring and Ground Connections

GFK-1047F
August 1997

24 VDC, 90W Power Supply Module

Warning

Because the power ON/OFF switch **does not** disconnect power from the internal storage elements, it is possible for the input terminals to discharge to user wiring when power is reapplied. To prevent this condition, **turn the power supply switch on after the removal of user input power** to discharge all stored energy through the supply.

System Noise Immunity

Two easy steps must be taken to properly ground the programmable controller system to reduce the possibility of errors due to electrical noise.

1. The GND terminal on the power supply must be connected to the GND terminal on either side of the rack using AWG #12 (3.3 mm²) wire. Use of a ring terminal and starwasher is recommended.
2. The GND terminal on the rack must be connected to a good earth ground.

Table 1. Specifications For IC697PWR724/CE697PWR724 †

Nominal Rated Voltage:	24 VDC
Input Voltage Range:	18 to 32 VDC
Input Power:	160 watts maximum @ full load
Input Inrush Energy:	22 joules maximum
Output Power:	90 watts maximum (total for all 3 outputs)
Output Voltage:	+5 VDC: 4.90 to 5.25 volts (5.07 volts nominal) +12 VDC: 11.75 to 12.6 volts -12 VDC: -12.6 to -11.75 volts
Protective Limits - Overvoltage Limit:	+5 VDC Output: 5.7 to 6.7 volts
Overcurrent Limit:	+5 VDC output: 26 amps, maximum +12 VDC output: 4 amps, maximum -12 VDC output: 2 amps, maximum
Ride Through Time:	10 milliseconds minimum @20 VDC
VME	System designed to support the VME standard C.1

† Refer to data sheet GFK-0867B, or later for product standards and general specifications.

Table 2. Ordering Information

Description	Catalog Number
Power Supply, 24 Volts DC, 90 Watts	IC697PWR724 CE697PWR724
Power Supply Extension Cable (includes cable and faceplate for vacant power supply slot in second rack).	IC697CBL700

Note: For Low Temperature Testing option please consult the factory for price and availability.

24 VDC, 90W Power Supply Module

GFK-1047F
August 1997

The following markings are required to appear in the applicable Programmable Controller Installation

Manual and data sheet for Class I Div 2 Hazardous Locations.

1. EQUIPMENT LABELED WITH REFERENCE TO CLASS I, GROUPS A, B, C, and D, DIV. 2 HAZARDOUS LOCATIONS IS SUITABLE FOR USE IN CLASS I, DIVISION 2, GROUPS A, B, C, D OR NON-HAZARDOUS LOCATIONS ONLY.
2. WARNING - EXPLOSION HAZARD - SUBSTITUTION OF COMPONENTS MAY IMPAIR SUITABILITY FOR CLASS I, DIVISION 2.
3. WARNING - EXPLOSION HAZARD - DO NOT DISCONNECT EQUIPMENT UNLESS POWER HAS BEEN SWITCHED OFF OR THE AREA IS KNOWN TO BE NON-HAZARDOUS.

GFK-1061D
August 1997

48 VDC 90W Power Supply Module

Features

- Operation from 48 VDC
- Three output voltages, 90 watts total
 - +5 VDC output up to 18 amps
 - +12 VDC output up to 1.5 amps
 - 12 VDC output up to 1 amp
- Slide-in rack mount construction
- Electronic short circuit overcurrent protection provided on 5 volt bus
- Two rack operation from a single power supply

Functions

This 90 Watt Power Supply Module is a rack-mounted

unit that plugs directly into a 48-pin backplane-mounted connector in the leftmost slot in the rack. It provides +5 volt, +12 volt and -12 volt power, and logic level sequencing signals to the backplane.

This power supply can be used either in a single rack application, or can also be used to provide power to a second rack if the total load is within the supply rating. Interconnection to the second rack is through a pre-wired cable (IC697CBL700).

The power supply output will ride through a 10 msec total loss of input power at full load. Protection is provided for overcurrent and overvoltage fault conditions.

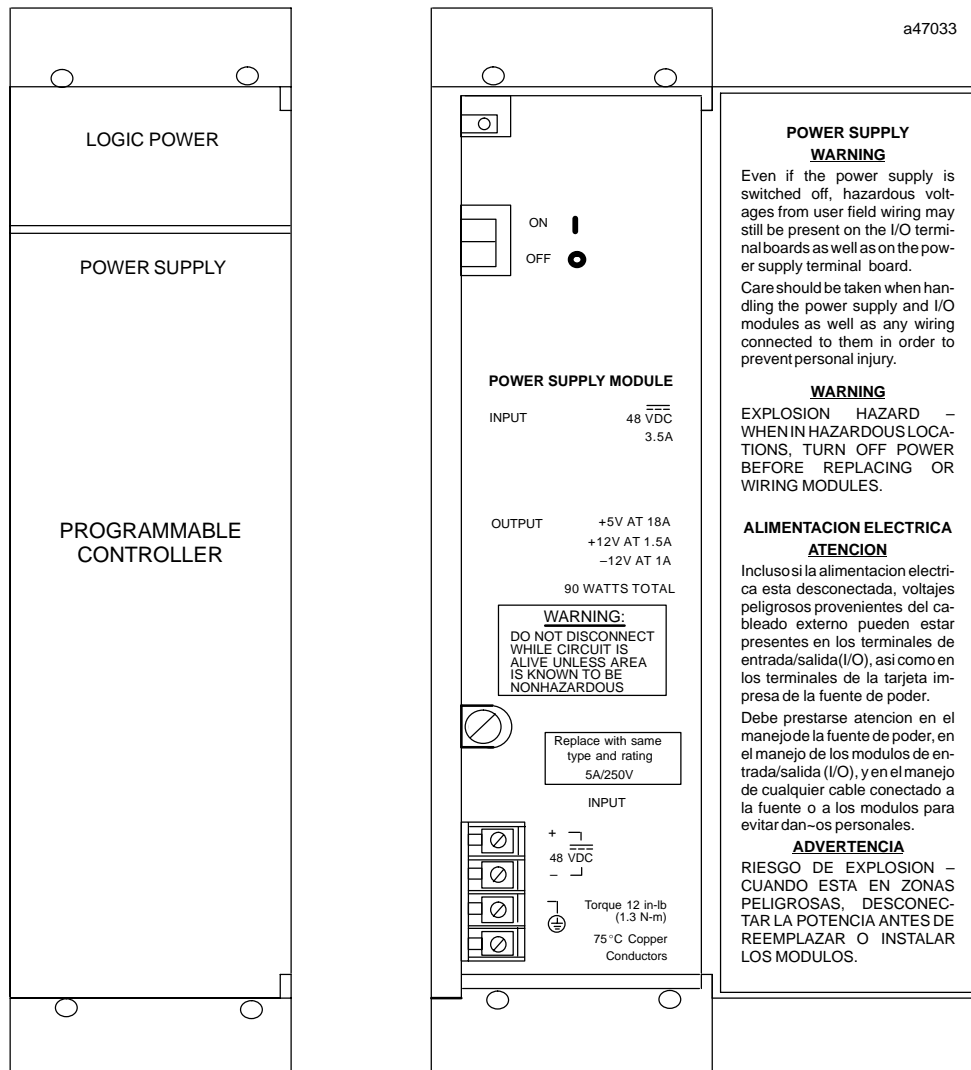

GFK-1061D
August 1997

48 VDC 90W Power Supply Module

Operation of the Power Supply

This Power Supply Module operates from a 48 VDC nominal line. The power supply can accept an input voltage range of from 35 to 60 VDC.

Overvoltage Protection

The power supply includes an electronic overvoltage protection circuit. This circuit will clamp the output if the 5 V bus exceeds 6.7 volts. External overvoltage on the output will not cause the power supply fuse to open. However, if an internal fault in the power supply caused the overvoltage condition, the fuse may open. Replace this fuse with a 5 amp, 250 volt 5x20 mm fuse.

Overcurrent Protection

The power supply provides an electronic overcurrent limit for each of the three outputs (26 amps for +5V, 4 amps for +12 V, and 2 amps for -12 V (all maximum)). If the maximum current rating is exceeded, the output voltage will drop.

It will remain in that state until the load is either removed or reduced. A current overload (including a short circuit condition) will not cause the fuse to open.

Temperature Derating

For operation at ambient temperatures that exceed 50°C (122°F), maximum output power must be derated as shown in the derating curve.

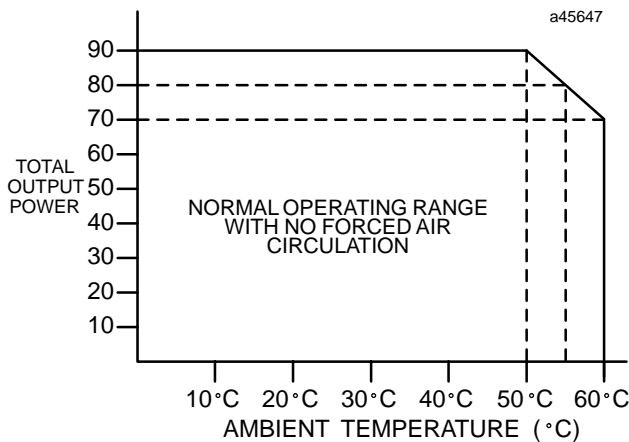

Figure 1. Output Power Derating Curve

Dual Rack Operation

A single power supply can provide power for two racks under the following conditions:

- Only 5 volt power is required in the second rack, and the total power required by both racks is within the capability of the supply.
- The current drawn by the second rack is less than 5.2 amperes.
- The two racks must be mounted in close proximity as limited by the available 3-foot connecting cable.

The connecting cable used for dual rack operation is listed in Table 2, *Ordering Information*. This cable carries the +5 volt power bus as well as the power sequencing signals. It uses a 9-pin D-type connector which connects directly to the backplane through an opening in the rack frame. Note that the cable carries power and power sequencing signals only. Inter-rack communication and bus interface modules must be provided separately. See the applicable *Programmable Controller Installation Manual* for application information.

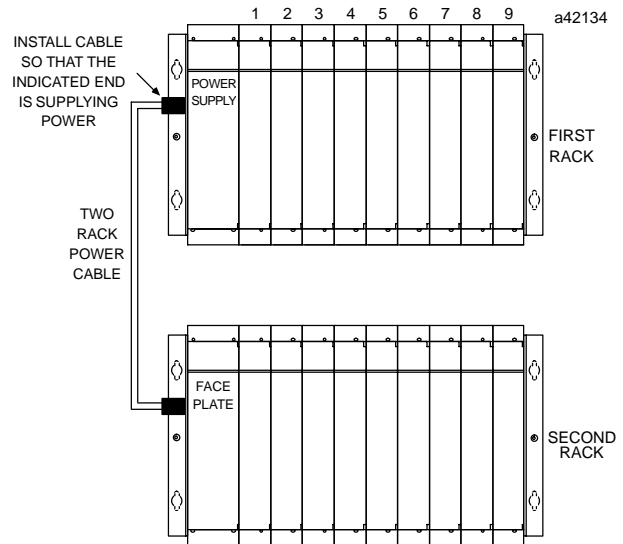

Figure 2. Dual Rack Configuration

Timing Diagram

The timing diagram below shows the relationship of the dc input power to the dc outputs and to the two system signals generated by the power supply: *ACFAIL* and *SYS-RESET*. The *5VSTBY* output can be used for user battery backup schemes as shown.

On application of power, the *ACFAIL* signal goes false soon after the 5 volt bus is within specification. The sys-

48 VDC 90W Power Supply Module

GFK-1061D
August 1997

tem is held in the Reset state by SYSRESET for at least 200 milliseconds after 5 volt power is available (during this time, outputs are forced off).

If input power is interrupted, the 5 volt bus will remain within specifications for at least 10 milliseconds. The system is then given an additional 5 milliseconds to complete an orderly shutdown before SYSRESET stops all processing.

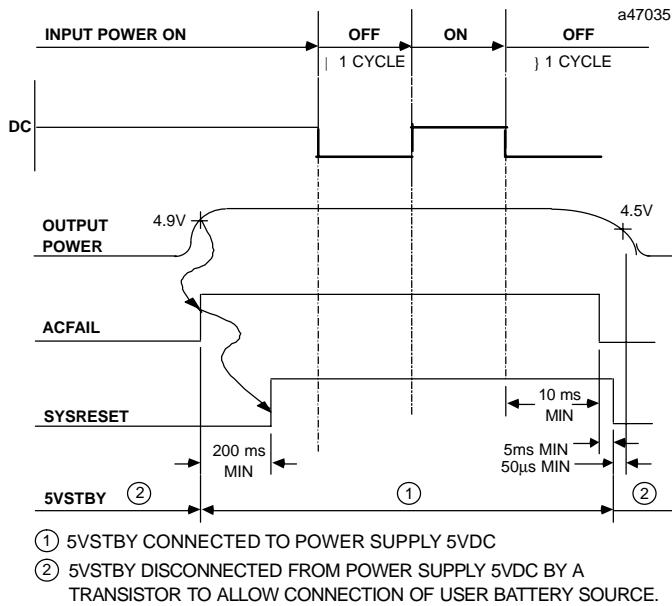

Figure 3. Timing Diagram for 48 VDC Power Supply

Note

Input power interruptions that exceed the power supply ride through time (10 milliseconds minimum) will result in a complete power down/power up cycle of ACFAIL and SYSRESET.

Inrush

When input voltage is initially applied, internal energy storage elements will draw a surge current from the 48 VDC input power source which can be in the range of 100 amps depending on the installation and power source impedance characteristics. Standard best practices should be used for installations where minimizing inrush current is a consideration. Typical best practices include providing local energy storage which can be either system batteries or capacitors at each power supply input, and minimizing resistance from the storage elements to prevent significant voltage drop during the initial energy transfer.

Note that this inrush *only occurs* during the initial application of input voltage to the power supply. Turning

the power switch On and OFF *does not* disconnect power from internal energy storage elements, and therefore does not require inrush energy from the power source.

Mounting

The Power Supply is a plug-in module which is secured to the rack with four M 2.5 screws (included). Be certain that these screws are tightened both to secure the power supply to the rack, and to assure proper power supply-to-rack grounding.

Power Supply Door

The power supply door can be opened by grasping the upper left corner of the door with your right thumb or a fingernail and gently pulling the door towards you. Use care when opening the door since pulling from the bottom can cause the hinge or the door to break.

Input Voltage and Grounding

The power input terminal board provides two terminals for connecting 48 VDC power and an additional terminal for system and noise ground. Power input connections should be made with copper AWG #16 (1.33 mm²) through AWG #12 (3.31 mm²) wire rated for 75°C (167°F).

Each terminal can accept solid or stranded wires, but the wires into any given terminal should be the same type and size.

It is recommended that the GND terminal on the power supply be connected to the GND terminal on the rack and to earth using copper AWG #12 (3.3 mm²) wire rated for 75°C (167°F) and a ring terminal to ensure adequate grounding. Use of a nut and star washer for each wire on the GND lug is recommended.

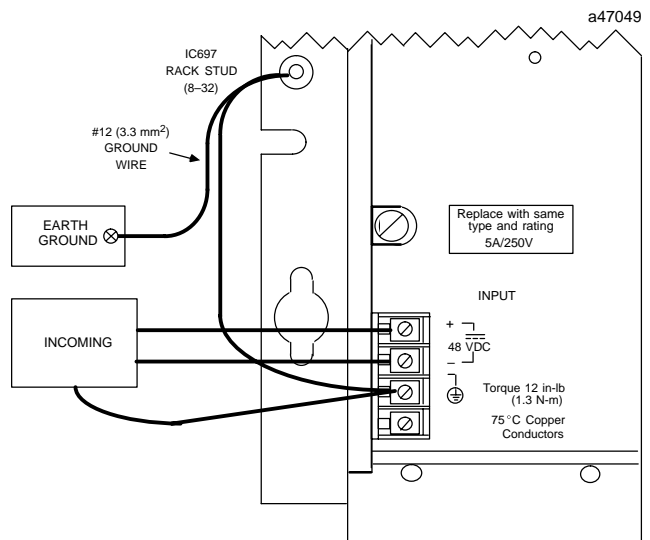

GFK-1061D
August 1997

48 VDC 90W Power Supply Module

Figure 4. Input Wiring and Ground Connections

Warning

Because the power ON/OFF switch **does not** disconnect power from the internal storage elements, it is possible for the input terminals to discharge to user wiring when power is reapplied. To prevent this condition, **turn the power supply switch on** after the removal of user input power to discharge all stored energy through the supply.

System Noise Immunity

Two easy steps must be taken to properly ground the programmable controller system to reduce the possibility of errors due to electrical noise.

- The GND terminal on the power supply must be connected to the GND terminal on either side of the rack using AWG #12 (3.3 mm²) wire. Use of a ring terminal and starwasher is recommended.
- The GND terminal on the rack must be connected to a good earth ground.

Table 1. Specifications For IC697PWR724/CE697PWR724 †

Nominal Rated Voltage:	48 VDC
Input Voltage Range:	35 to 60 VDC
Input Power:	160 watts maximum @ full load
Input Inrush Energy:	28 joules maximum at 60 VDC Input
Output Power:	90 watts maximum (total for all 3 outputs)
Output Voltage:	+5 VDC: 4.90 to 5.25 volts (5.07 volts nominal) +12 VDC: 11.75 to 12.6 volts -12 VDC: -12.6 to -11.75 volts
Minimum Load:	1.0 A on +5 VDC
Protective Limits -	
Overvoltage Limit:	+5 VDC Output: 5.7 to 6.7 volts
Overcurrent Limit:	+5 VDC output: 26 amps, maximum +12 VDC output: 4 amps, maximum -12 VDC output: 2 amps, maximum
Ride Through Time:	10 milliseconds minimum
VME	System designed to support the VME standard C.1

† Refer to data sheet GFK-0867B, or later for product standards and general specifications.

Table 2. Ordering Information

Description	Catalog Number
Power Supply, 48 Volts DC, 90 Watts	IC697PWR748 CE697PWR748
Power Supply Extension Cable (includes cable and faceplate for vacant power supply slot in second rack).	IC697CBL700

Note: For Low Temperature Testing option please consult the factory for price and availability.

48 VDC 90W Power Supply Module

GFK-1061D
August 1997

The following markings are required to appear in the applicable Programmable Controller Installation

Manual and data sheet for Class I Div 2 Hazardous Locations.

1. EQUIPMENT LABELED WITH REFERENCE TO CLASS I, GROUPS A, B, C, and D, DIV. 2 HAZARDOUS LOCATIONS IS SUITABLE FOR USE IN CLASS I, DIVISION 2, GROUPS A, B, C, D OR NON-HAZARDOUS LOCATIONS ONLY.
2. WARNING - EXPLOSION HAZARD - SUBSTITUTION OF COMPONENTS MAY IMPAIR SUITABILITY FOR CLASS I, DIVISION 2.
3. WARNING - EXPLOSION HAZARD - DO NOT DISCONNECT EQUIPMENT UNLESS POWER HAS BEEN SWITCHED OFF OR THE AREA IS KNOWN TO BE NON-HAZARDOUS.

Power Supplies

IC697PWR710/712

GFK-1388A
August 1997

120/240 VAC or 125 VDC, 55W Power Supply Module

- This data sheet (GFK-1388) describes version H (IC697PWR710H/712H), or later versions of this power supply.
- For a description of version G (IC697PWR710G/712G), and earlier versions – see data sheet GFK-0083L.

Features

- Operation from 120/240 VAC or 125 VDC
- Five volt DC output up to 11 amps
- Slide-in rack mount construction
- Electronic short circuit overcurrent protection provided on 5 volt bus
- Two rack operation from a single power supply
- Power factor corrected on AC inputs
- Jumper for overvoltage protection devices

Functions

This **Power Supply Module** for the programmable controller is a rack-mounted unit that plugs directly

into a 48-pin backplane-mounted connector in the leftmost slot in the rack. It provides +5 volt power and logic level sequencing signals to the backplane.

This power supply may be used either in a single rack application, or may also be used to provide power to a second rack if the total load is within the supply rating. Interconnection to the second rack is through an available prewired cable (see the ordering instructions on the last page of this data sheet).

The power supply output will ride through a one-cycle total loss of input power at full load. Protection is provided for overcurrent and overvoltage fault conditions.

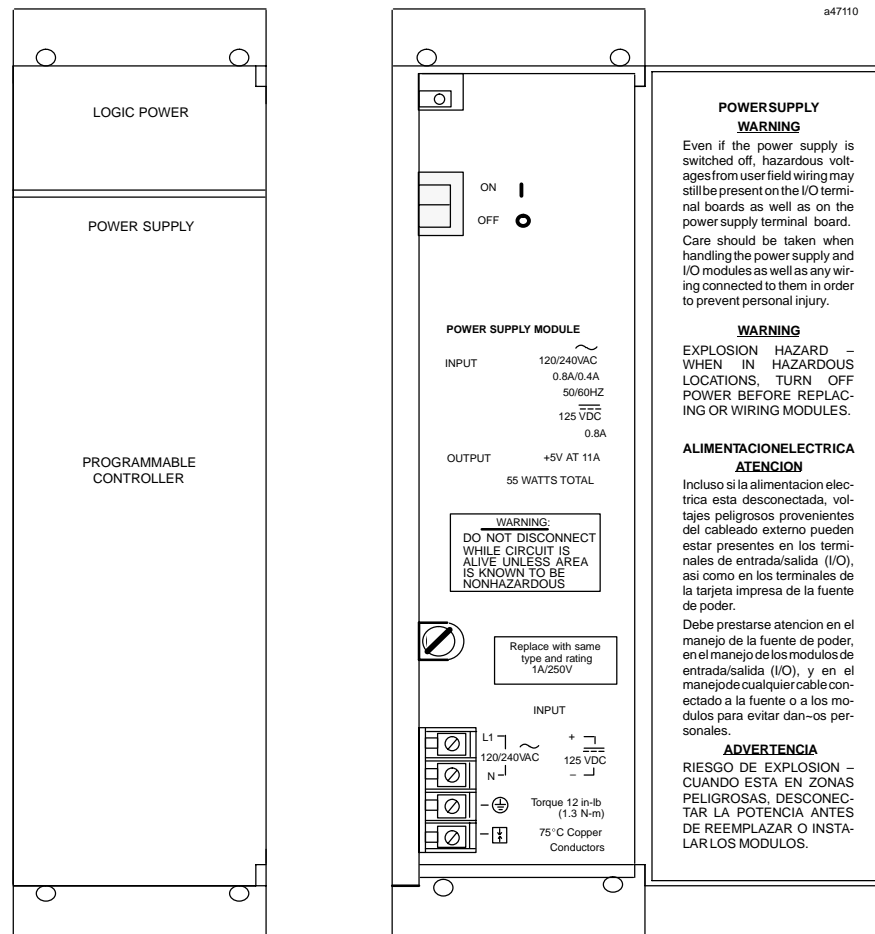

GFK-1388A
August 1997

120/240 VAC or 125 VDC, 55W Power Supply Module

Operation of the Power Supply

This Power Supply Module can operate from either a 120 VAC or 240 VAC nominal line. For these two ranges, the power supply can accept an input voltage range of from 90 to 264 VAC, 47 to 63 Hz. Active power factor correction circuits in this supply maintain a unity power factor which eliminates the need for oversized circuit breakers and wiring.

This power supply will also operate with a 125 VDC nominal line. It will accept a DC input voltage range of 100 to 150 VDC.

Overvoltage Protection

The power supply includes an electronic overvoltage protection circuit. This circuit will clamp the output if the 5 volt bus exceeds 6.2 volts. External overvoltage on the output will not cause the power supply fuse to open. However, if an internal fault in the power supply caused the overvoltage condition, the fuse may open. Replace this fuse with a 1 amp, 250 volt 5x20 mm fuse.

Overcurrent Protection

The power supply provides an electronic overcurrent limit at 12 amperes, typical. If the maximum current rating is exceeded, the output voltage will drop.

It will remain in that state until the load is either removed or reduced. A current overload (including a short circuit condition) will not cause the fuse to open.

Dual Rack Operation

A single power supply can provide power for two racks under the following conditions:

- Only 5 volt power is required in the second rack, and the total power required by both racks is within the capability of the supply.
- The current drawn by the second rack is less than 5.2 amperes.
- The two racks must be mounted in close proximity as limited by the 3-foot connecting cable.

The connecting cable used for dual rack operation is listed in the ordering instructions. This cable carries the +5 volt power bus as well as the power sequencing signals. It uses a 9-pin D-type connector which

connects directly to the backplane through an opening in the rack frame.

Note that the cable carries power and power sequencing signals only. Inter-rack communication and bus interface modules must be provided separately. See the applicable *Programmable Controller Installation Manual* for application information.

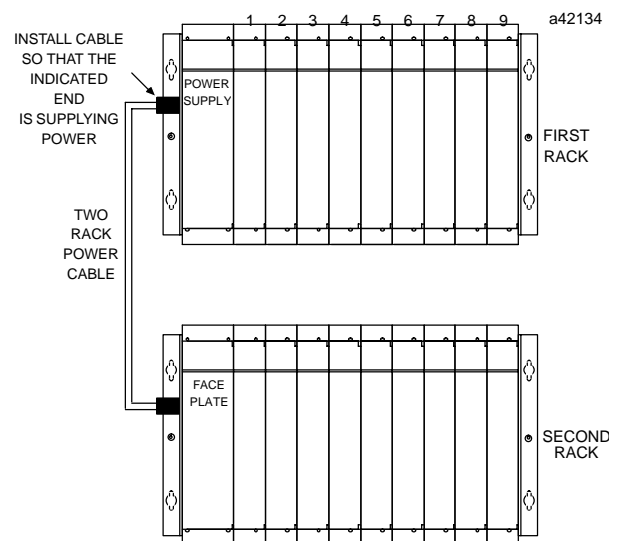

Figure 1. Dual Rack Configuration

Timing Diagram

The timing diagram below shows the relationship of the AC input power to the 5 volt DC output and to the two system signals generated by the power supply: *ACFAIL* and *SYSRESET*.

On application of power, the *ACFAIL* signal goes false soon after the 5 volt bus is within specification. The system is held in the Reset state by *SYSRESET* for at least 200 milliseconds after 5 volt power is available. (During this time, outputs are forced off).

If AC input power is interrupted, the 5 volt bus will remain within specifications for at least one cycle. The system is then given an additional 5 ms to complete an orderly shutdown before *SYSRESET* stops all processing.

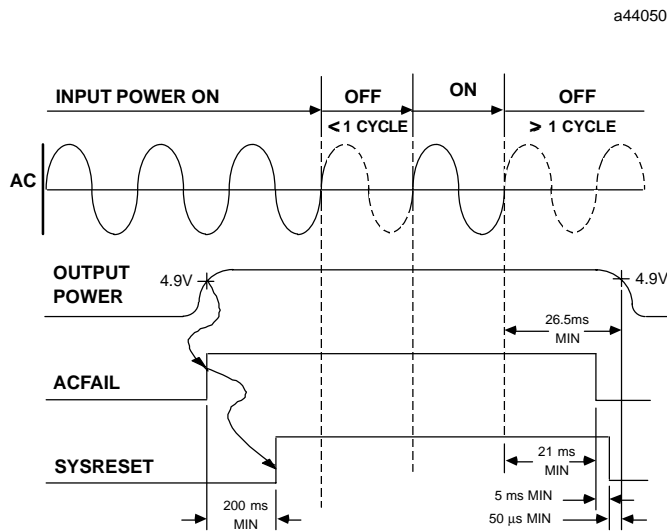

Figure 2. Timing Diagram for Versions D and Later

Note

Input power interruptions which exceed the power supply ride through time (21 milliseconds minimum) will result in a complete power down/power up cycle of ACFAIL and SYSRESET

Mounting

The Power Supply is a plug-in module that is installed in the leftmost slot of any standard IC697 rack or VME Integrator's rack.

Power Supply Door

The power supply door can easily be opened by grasping the upper left corner of the door with your right thumb or a fingernail and gently pulling the door towards you. Use care when opening the door since pulling from the bottom can cause the hinge or the door to break.

Field Wiring Connections

The power input terminal board has four terminals. The top two (L1 and N) are for 120/240 VAC or 125 VDC input power connections; the third and fourth terminals are for ground and overvoltage protection device connections, respectively. Power input connections should be made with copper AWG #16 (1.3 mm²) wire rated for 75°C (167°F). Each terminal can accept solid or stranded wires, but the wires into any given terminal should be the same type and size.

It is recommended that the **ground** terminal on the power supply be connected to the GND terminal on the rack and to earth using copper AWG #12 (3.3 mm²) wire rated for 75°C (167°F) to ensure adequate grounding.

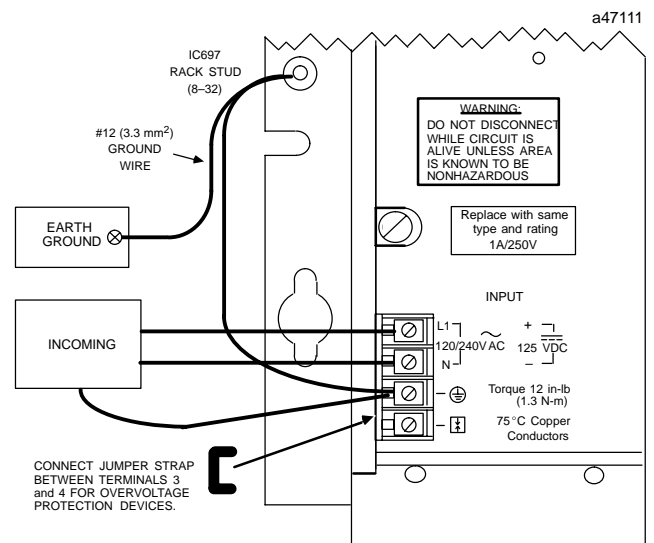

Figure 3. Terminal Board Connections for IC697PWR710/712, Versions H and Later

Overvoltage Protection Devices

The overvoltage protection devices (see Figure 4) for this power supply are connected internally to terminal 4 (bottom terminal) on the input terminal board. This pin is normally connected to frame ground (terminal 3) with the supplied jumper strap which is installed at the factory. If overvoltage protection is not required or is supplied upstream, this feature can be disabled by leaving terminal 4 unconnected by removing the jumper strap.

GFK-1388A
August 1997

120/240 VAC or 125 VDC, 55W Power Supply Module

If you want to Hi-pot test this supply, overvoltage protection **must be disabled** during the test by removing the terminal board strap. Re-enable overvoltage protection after testing by reinstalling the strap.

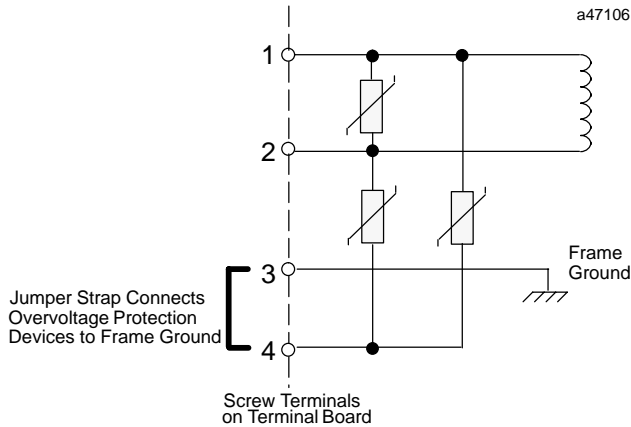

Figure 4. Overvoltage Protection Devices and Jumper

System Noise Immunity

Two easy steps must be taken to properly ground the programmable controller system to reduce the possibility of errors due to electrical noise.

1. A ground terminal on the power supply must be connected to the GND terminal on either side of the rack using AWG #12 (3.3 mm²) wire.
2. The GND terminal on the rack must be connected to a good earth ground.

Table 3. Specifications for IC697PWR710/712 (Versions H and Later) †

Nominal Rated Voltage:	120/240VAC or 125 VDC
Input Voltage Range: AC DC	90 to 264 VAC, 47 to 63 Hz 100 to 150 VDC,
Input Power:	90 watts maximum at full load
Input Half Cycle Peak Inrush:	3 amps (typical)
Power Factor	> .95
Output Power:	56 watts maximum
Output Voltage:	+5 VDC: 4.90 to 5.25 volts (5.1 volts nominal)
Protective Limits -	
Overvoltage Limit:	6.2 volts (typical), <i>electronic overvoltage protection</i>
Overcurrent Limit:	12 amps (typical), <i>electronic current limit</i>
Ride Through Time:	21 milliseconds minimum (from loss of AC input)
VME	System designed to support the VME standard C.1

† Refer to data sheet GFK-0867C, or later for product standards and general specifications.

Table 4. Ordering Information

Description	Catalog Number
Power Supply - 120/240 Volts AC or 125 Volts DC, 55 Watts (H, or later version)	IC697PWR710/712
Power Supply Extension Cable (includes cable and faceplate for vacant power supply slot in second rack)	IC697CBL700/713

Special Installation Instructions for Floating Neutral (IT) Systems

When this power supply is installed in a system where the Neutral line is **not** referenced to Protective Earth Ground, these special installation instructions must be followed to prevent damage to the power supply.

Definition of Floating Neutral Systems

As described in this data sheet a *Floating Neutral System* is a system of power distribution wiring where Neutral and Protective Earth Ground are **not** tied together by a negligible impedance. In Europe this is referred to as an **IT** system (see IEC950). In a *Floating Neutral System*, voltages measured from input terminals to protective earth ground may exceed 264 Volts AC maximum input voltage as specified in the power supply specifications in this data sheet.

Example of Floating Neutral System

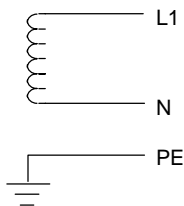

This system **must** be installed using the special installation instructions on this page.

Systems in which one leg of the power distribution wiring is tied to Protective Earth or a tap between two legs of the power distribution wiring is tied to Protective Earth are **not** *Floating Neutral Systems*.

Examples of Non-Floating Neutral System

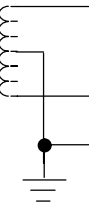
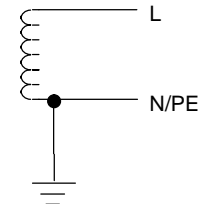
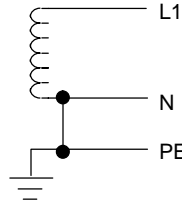

These systems **do not** require these special installation instructions.

Use These Special Installation Instructions for Floating Neutral Systems

1. The input power terminals should be wired according to the instructions in this data sheet.
2. The factory installed jumper between terminals 3 and 4 of the power supply module **must** be removed.
3. Voltage surge protection devices, such as MOVs, **MUST** be installed between the following terminals:
 - From L1 to earth ground
 - From L2 (Neutral) to earth ground

The voltage surge devices must be rated such that the system is protected from power line transients that exceed $Line\ voltage + 100V + (N-PE)_{MAX}$.

For example, in a 240 Volt AC system with neutral floating 50V above earth ground, the transient protection should be rated at:

$$240V + 100V + 50V = 390V$$

GFK-1388A
August 1997

120/240 VAC or 125 VDC, 55W Power Supply Module

The following statements are required to appear for Class I Div 2 Hazardous Locations.

1. EQUIPMENT LABELED WITH REFERENCE TO CLASS I, GROUPS A, B, C, and D, DIV. 2 HAZARDOUS LOCATIONS IS SUITABLE FOR USE IN CLASS I, DIVISION 2, GROUPS A, B, C, D OR NON-HAZARDOUS LOCATIONS ONLY.
2. WARNING - EXPLOSION HAZARD - SUBSTITUTION OF COMPONENTS MAY IMPAIR SUITABILITY FOR CLASS I, DIVISION 2.
3. WARNING - EXPLOSION HAZARD - DO NOT DISCONNECT EQUIPMENT UNLESS POWER HAS BEEN SWITCHED OFF OR THE AREA IS KNOWN TO BE NON-HAZARDOUS.

Power Supplies

IC697PWR711/713

GFK-1448B
August 1997

Power Supply Module, 100W, 120/240 VAC or 125 VDC

-This data sheet describes version H (IC697PWR711H/713H), or later versions of this power supply.
-F or a description of version G (IC697PWR711G/713G), and earlier versions – see data sheet GFK-0392G.

Features

- Operation from 120 VAC, 240 VAC, or 125 VDC
- Three output voltages, 100 watts total
 - +5 VDC output up to 20 amps
 - +12 VDC output up to 2 amps
 - 12 VDC output up to 1 amp
- Slide-in rack mount construction
- Electronic short circuit overcurrent protection
- Two rack operation from a single power supply
- Power Factor correction for AC operation
- Jumper for overvoltage protection devices

Functions

The **100 Watt Power Supply Module** is a rack-mounted unit that plugs directly into a 48-pin backplane-mounted connector in the leftmost slot in the rack. It provides +5 volt, +12 volt and -12 volt power, and logic level sequencing signals to the backplane.

This power supply may be used either in a single rack application, or may also be used to provide power to a second rack if the total load is within the supply rating. Interconnection to the second rack is through a pre-wired cable (see the ordering instructions on the last page of this data sheet).

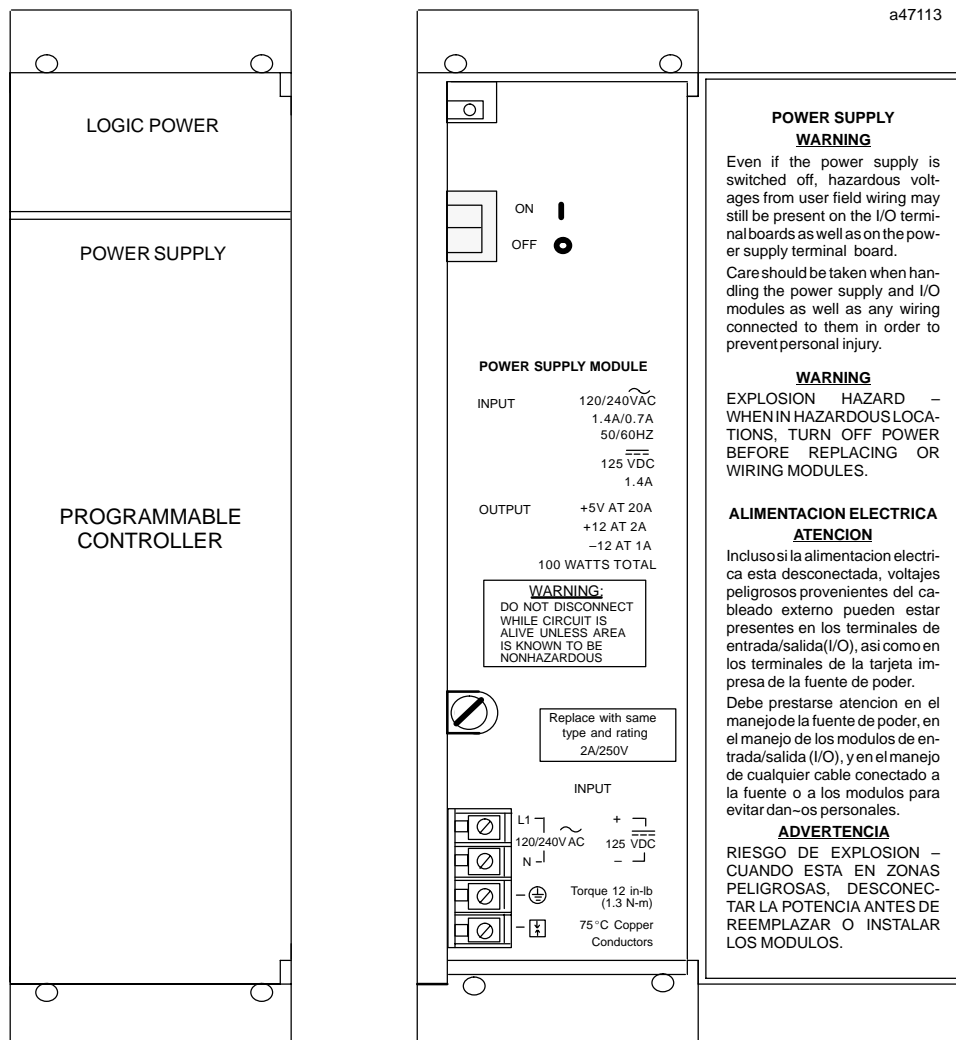

GFK-1448B
August 1997

Power Supply Module, 100W, 120/240 VAC or 125 VDC

The power supply output will ride through at least one input line cycle with a total loss of input power at full load. Protection is provided for overcurrent and over-voltage fault conditions.

Operation of the Power Supply

This Power Supply module can operate from either 120 VAC or 240 VAC nominal inputs. It will also operate from a nominal 125 VDC source. The specified range of operation is from 90 VAC to 264 VAC, and from 100 VDC to 150 VDC.

For continuous operation (greater than one hour) at low line voltages and high temperatures, some power

derating must be applied. Refer to the following figure to determine the normal operating range for specific applications. Normal operating range is shown by the shaded area of the graph for 60°C (140°F) installations. Operation in the non-shaded region for specific applications must be limited to <1 hour. Reducing the maximum operating temperature to 55°C (131°F) will increase the normal operating range as indicated on the graph.

Active power factor correction circuits in this supply maintain a near unity power factor for AC inputs, which eliminates the need for oversized circuit breakers and wiring. This circuitry also limits the half cycle peak inrush currents to a low value.

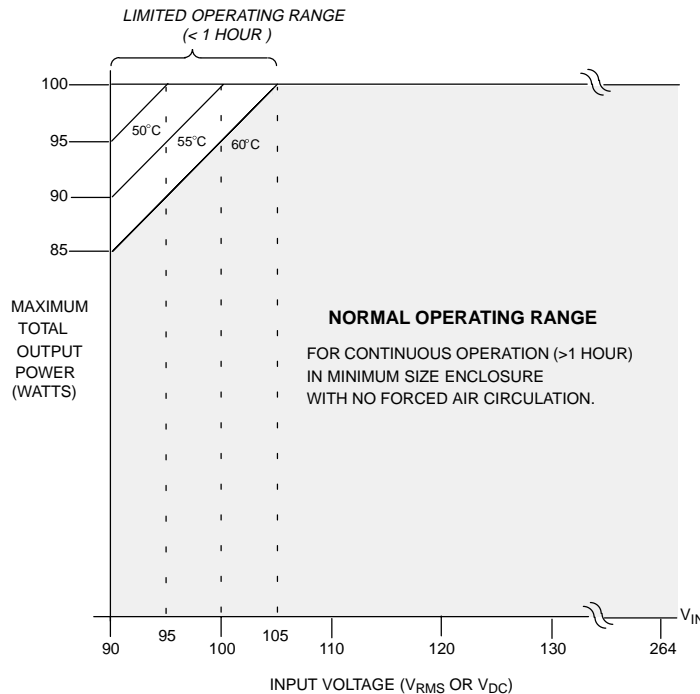

Figure 1. Power Derating for Low Line Voltages

Overvoltage Protection

An electronic shutdown circuit protects against voltages exceeding 6.2 volts. A back-up voltage clamp is provided to protect against sustained overvoltage conditions due to either external influences or internal faults. Overvoltage due to internal faults may cause the fuse to open. For short term overvoltage conditions, normal operation will resume when the cause is removed.

Overcurrent Protection

An electronic current limit is provided on each of the three outputs. An overload on any output will cause the voltage to collapse and may cause the other output voltages to collapse.

Normal operation will resume after removal of the overload. Some component cooling time may be required before normal operation resumes.

Dual Rack Operation

A single power supply can provide power for two racks under the following conditions:

- Only 5 volt power is required in the second rack, and the total power required by both racks is within the capability of the supply.
- The current drawn by the second rack is less than 5.2 amperes.
- The two racks must be mounted in close proximity as limited by the available 3-foot connecting cable.

The connecting cable used for dual rack operation is listed in Table 2, Ordering Information. This cable carries the +5 volts power bus as well as the power sequencing signals. It uses a 9-pin D-type connector which connects directly to the backplane through an opening in the rack frame. Note that the cable carries power and power sequencing signals only. Inter-rack communication and bus interface modules must be provided separately. See the applicable *Programmable Controller Installation Manual* for application information.

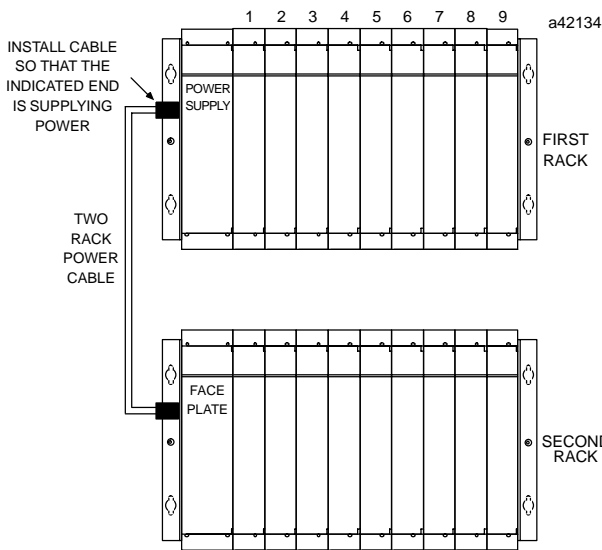

Figure 2. Dual Rack Configuration

Timing Diagram

The timing diagram below shows the relationship of the ac input power to the dc outputs and to the two system signals generated by the power supply: *ACFAIL* and *SYSRESET*.

SET. The 5VSTBY output may be used for user battery backup schemes as shown.

On application of power, the *ACFAIL* signal goes false soon after the 5 volt bus is within specification. The system is held in the Reset state by *SYSRESET* for at least 200 milliseconds after 5 volt power is available (during this time, outputs are forced off).

If AC input power is interrupted, the 5 volt bus will remain within specifications for at least one cycle. The system is then given an additional 5 milliseconds to complete an orderly shutdown before *SYSRESET* stops all processing.

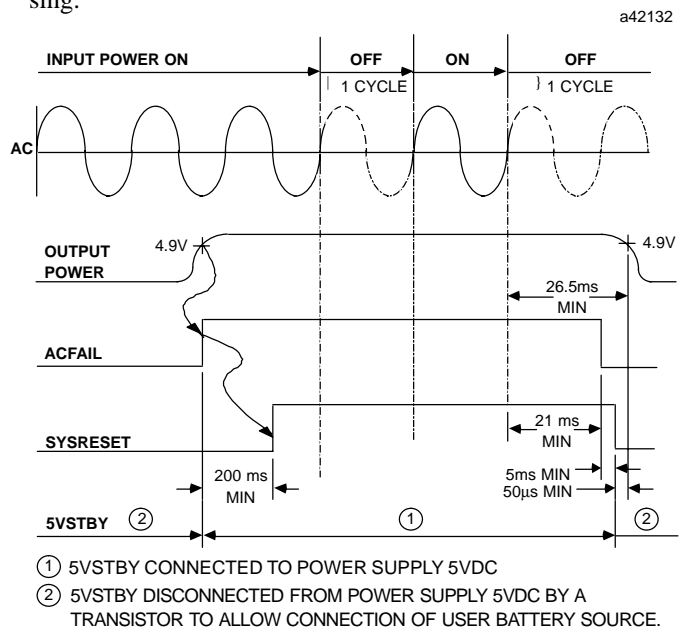

- ① 5VSTBY CONNECTED TO POWER SUPPLY 5VDC
- ② 5VSTBY DISCONNECTED FROM POWER SUPPLY 5VDC BY A TRANSISTOR TO ALLOW CONNECTION OF USER BATTERY SOURCE.

Figure 3. Timing Diagram

Note

Input power interruptions which exceed the power supply holdup time (21 milliseconds minimum) will result in a complete power down/power up cycle of *ACFAIL* and *SYSRESET*.

Mounting

This Power Supply is a plug-in module that is installed in the leftmost slot of any standard IC697 rack or VME Integrator's rack. For additional installation information, refer to GFK-1179, *Installation Guidelines for Conformance to Standards*, shipped with the PLC programming software.

GFK-1448B
August 1997

Power Supply Module, 100W, 120/240 VAC or 125 VDC

Power Supply Door

The power supply door can easily be opened by grasping the upper left corner of the door with your right thumb or a fingernail and gently pulling the door towards you. Use care when opening the door since pulling from the bottom can cause the hinge or the door to break.

Field Wiring Connections

The power input terminal board has four terminals. The top two (L1 and N) are for 120/240 VAC or 125 VDC input power connections; the third and fourth terminals are for ground and overvoltage protection device connections, respectively. Power input connections should be made with copper AWG #16 (1.3 mm²) wire rated for 75 °C (167 °F). Each terminal can accept solid or stranded wires, but the wires into any given terminal should be the same type and size.

It is recommended that the ground terminal on the power supply be connected to the GND terminal on the rack and to earth using copper AWG #12 (3.3 mm²) wire rated for 75 °C (167 °F) to ensure adequate grounding. Use of a nut and star washer for each wire on the ground terminal is recommended.

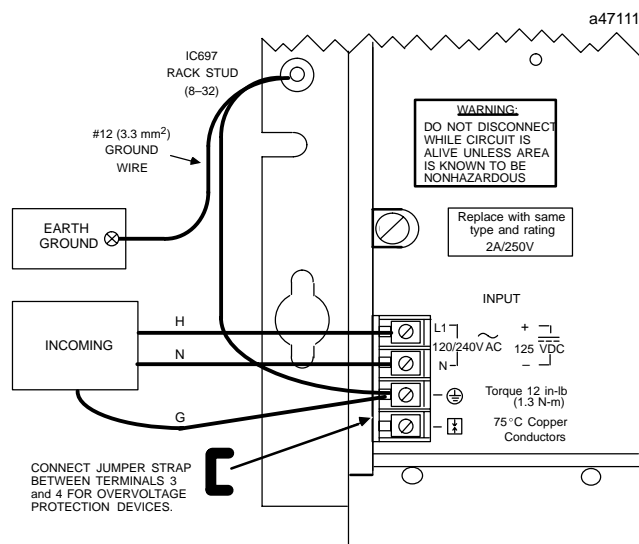

Figure 4. Terminal Board Connections for IC697PWR711/713, Versions H and Later

Overvoltage Protection Devices

The overvoltage protection devices (see Figure 5) for this power supply are connected internally to terminal 4 (bottom terminal) on the input terminal board. This pin is normally connected to frame ground (terminal 3) with the supplied jumper strap which is installed at the factory. If overvoltage protection is not required or is supplied upstream, this feature can be disabled by leaving terminal 4 unconnected by removing the jumper strap.

If you want to Hi-pot test this supply, overvoltage protection **must be disabled** during the test by removing the terminal board strap. Re-enable overvoltage protection after testing by reinstalling the strap.

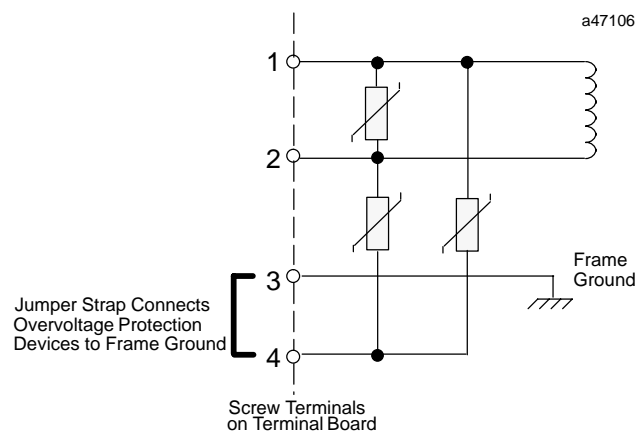

Figure 5. Overvoltage Protection Devices and Jumper

System Noise Immunity

Two easy steps must be taken to properly ground the programmable controller system to reduce the possibility of errors due to electrical noise (see Figure 5).

1. The Ground terminal on the power supply must be connected to the GND terminal on either side of the rack using AWG #12 (3.3 mm²) wire. The Ground terminal should be also be connected to incoming safety ground.
2. The GND terminal on the rack must be connected to a good earth ground.

Power Supply Module, 100W, 120/240 VAC or 125 VDCGFK-1448B
August 1997**Table 1. Specifications FOR IC697PWR711/713
(Version H and Later) †**

Nominal Rated Voltage:	120/240 VAC, or 125 VDC
Input Voltage Range: AC Input DC Input	90 to 264 VAC, 47 to 63 Hz 100 to 150 VDC
Input Power: Input Half Cycle Peak Inrush Power Factor	135 watts (typical), 160 watts (maximum) 3 amps (typical) > .93
Output Power: †† Output Voltage:	100 watts maximum (total for all 3 outputs) +5 VDC: 4.90 to 5.25 volts (5.07 volts nominal) +12 VDC: 11.75 to 12.6 volts -12 VDC: -12.6 to -11.75 volts
Protective Limits - Overvoltage Limit: Overcurrent Limit:	+5 VDC Output: 5.7 to 6.7 volts +5 VDC output: 21A (typical) +12 VDC output: 3.5A (typical) -12 VDC output: 1.6A (typical)
Holdup Time:	21 milliseconds minimum (from loss of AC input)
Environmental - Operating Temperature:	0°C to 60°C (32° to 140°F) operating †† -40°C to +85°C (-40° to +185°F) storage

† Refer to data sheet GFK-0867B, or later for product standards and general specifications.

†† Derate for continuous low input voltage, (see Figure 1)

Table 2. Ordering Information

Description	Catalog Number
Power Supply, 120/240 Volts AC, or 125 Volts DC 100 Watts (with jumper for overvoltage protection devices – version H, or later version)	IC697PWR711/713
Power Supply Extension Cable (includes cable and faceplate for empty power supply slot in second rack).	IC697CBL700

Note: For Low Temperature Testing option please consult the factory for price and availability.

GFK-1448B
August 1997

Power Supply Module, 100W, 120/240 VAC or 125 VDC

Special Installation Instructions for Floating Neutral (IT) Systems

When this power supply is installed in a system where the Neutral line is **not** referenced to Protective Earth Ground, these special installation instructions must be followed to prevent damage to the power supply.

Definition of Floating Neutral Systems

As described in this data sheet a *Floating Neutral System* is a system of power distribution wiring where Neutral and Protective Earth Ground are **not** tied together by a negligible impedance. In Europe this is referred to as an **IT** system (see IEC950). In a *Floating Neutral System*, voltages measured from input terminals to protective earth ground may exceed 264 Volts AC maximum input voltage as specified in the power supply specifications in this data sheet.

Example of Floating Neutral System

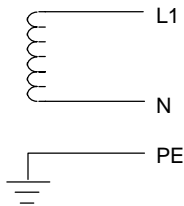

This system **must** be installed using the special installation instructions on this page.

Systems in which one leg of the power distribution wiring is tied to Protective Earth or a tap between two legs of the power distribution wiring is tied to Protective Earth are **not** *Floating Neutral Systems*.

Examples of Non-Floating Neutral System

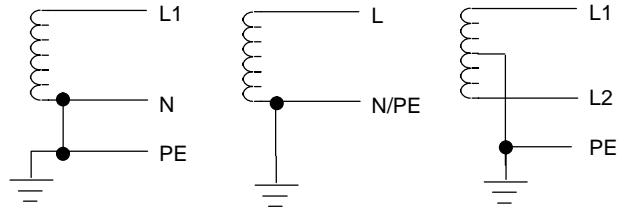

These systems **do not** require these special installation instructions.

Use These Special Installation Instructions for Floating Neutral Systems

1. The input power terminals should be wired according to the instructions in this data sheet.
2. The factory installed jumper between terminals 3 and 4 of the power supply module **must** be removed.
3. Voltage surge protection devices, such as MOVs, **MUST** be installed between the following terminals:
 - From L1 to earth ground
 - From L2 (Neutral) to earth ground

The voltage surge devices must be rated such that the system is protected from power line transients that exceed $\text{Line voltage} + 100V + (N-PE)_{MAX}$.

For example, in a 240 Volt AC system with neutral floating 50V above earth ground, the transient protection should be rated at:

$$240V + 100V + 50V = 390V$$

Power Supply Module, 100W, 120/240 VAC or 125 VDC

GFK-1448B
August 1997

The following statements are required to appear for Class I Div 2 Hazardous Locations.

1. EQUIPMENT LABELED WITH REFERENCE TO CLASS I, GROUPS A, B, C, and D, DIV. 2 HAZARDOUS LOCATIONS IS SUITABLE FOR USE IN CLASS I, DIVISION 2, GROUPS A, B, C, D OR NON-HAZARDOUS LOCATIONS ONLY.
2. WARNING - EXPLOSION HAZARD - SUBSTITUTION OF COMPONENTS MAY IMPAIR SUITABILITY FOR CLASS I, DIVISION 2.
3. WARNING - EXPLOSION HAZARD - DO NOT DISCONNECT EQUIPMENT UNLESS POWER HAS BEEN SWITCHED OFF OR THE AREA IS KNOWN TO BE NON-HAZARDOUS.

GFK-0626D

August 1997

Power Supply Adapter Module

Features

- Interfaces an external power supply to an IC697 rack
- Single-slot module
- Plugs into power supply slot in rack
- Easy connection to power supply

Functions

This **Power Supply Adapter Module (PSA)** for the IC697I/O system is a single-slot module that plugs into the power supply slot, which is the leftmost slot in an IC697 rack. The PSA module must be connected to an external power supply through a cable. The external power supply can be an IC697 power supply module (see GFK-0717), or other external power supply.

The +5, +12, and -12 VDC outputs, as well as the 5V remote sense, which are generated by an external power supply are connected to the IC697 rack backplane through the PSA. The maximum currents that can be supplied to the backplane through the PSA are: 18 amps on the +5 volt output, 2 amps on the +12 volt output, and 1 amp on the -12 volt output.

The PSA monitors the +5 volt output and the ttl compatible Input Power OK signal (*TTL*) from the external power supply. The Input Power OK signal (*TTL*) indicates that the external power supply input voltage is adequate to maintain hold-up time for an orderly system shutdown. The PSA also develops two backplane signals, *ACFAIL** and *SYSRESET**, which are for the power-up/powerdown sequence.

The external power supply must provide adequate hold-up time (5.05 milliseconds minimum, per ANSI/IEEE STD1014-1987) as well as an Input Power OK signal (*TTL*) to ensure an orderly system shutdown when power is removed.

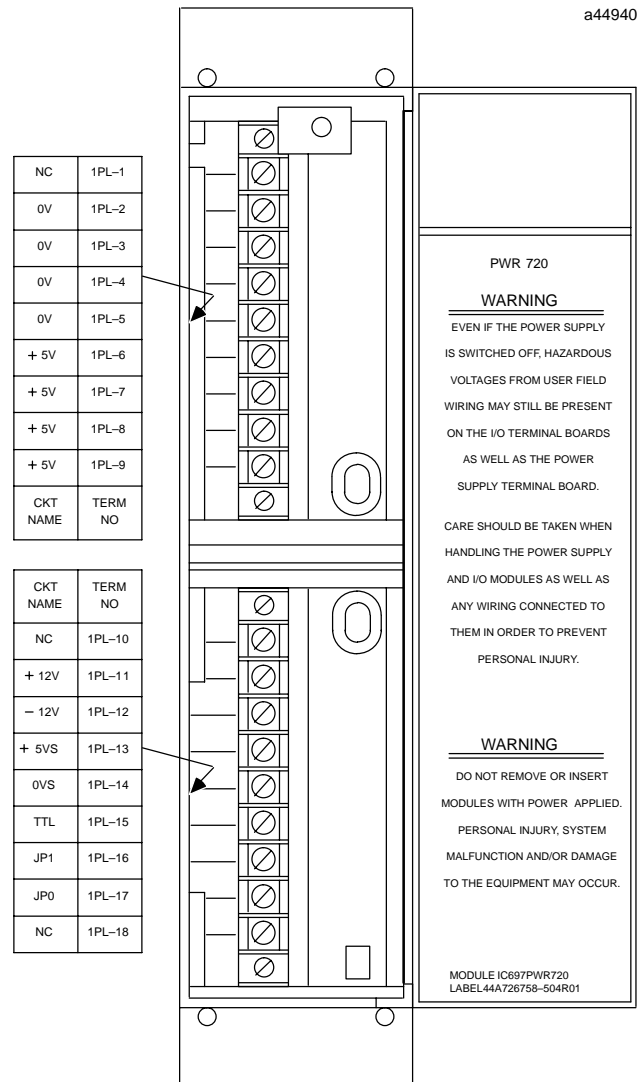

It is recommended that the external power supply have a +5V Remote Sense. When the Remote Sense is connected to the PSA terminal board (positive remote sense to +5VS and negative to 0VS) the +5 volts at the backplane will be regulated to the level set by the power supply.

GFK-0626D
August 1997

Power Supply Adapter Module

The LED indicator on the PSA is ON when the +5 volt output is in regulation at the backplane and the *TTL* signal from the power supply indicates that the power supply input voltage is adequate to maintain hold-up time for an orderly system shutdown. This *TTL* signal can be positive or negative logic. Two terminals on the PSA terminal board (JP1 and JP0) are available for selecting the logic state. If positive logic (Input Power OK if *TTL* = high), no jumper is required; if negative logic (Input Power OK if *TTL* = low), a jumper is required between terminals JP1 and JP0.

Operation of the Power Supply Adapter

This Power Supply Adapter Module operates from +5 VDC power which it receives from the +5 VDC power bus on the IC697 rack backplane.

Dual Rack Operation

A single external power supply can provide power for two racks. In this application, the PSA must be installed in the first rack. For detailed information on this application, refer to the applicable *Programmable Controller Installation Manual*.

Mounting

The Power Supply Adapter is a single-slot module that plugs into the power supply slot, which is the leftmost slot of an IC697 rack. It connects to the external power supply module through a cable that has one end connected to the power supply. The free end of the cable should have spring spade or ring lugs which must be connected to designated terminals on a terminal board on the Power Supply Adapter. This terminal board is accessed by opening the hinged door on the Power Supply Adapter module.

Power Supply Adapter Module Door

The Power Supply Adapter door can easily be opened by grasping the upper left corner of the door with your right thumb or a fingernail and gently pulling the door towards you. Use care when opening the door since pulling from the bottom can cause the hinge or the door to break.

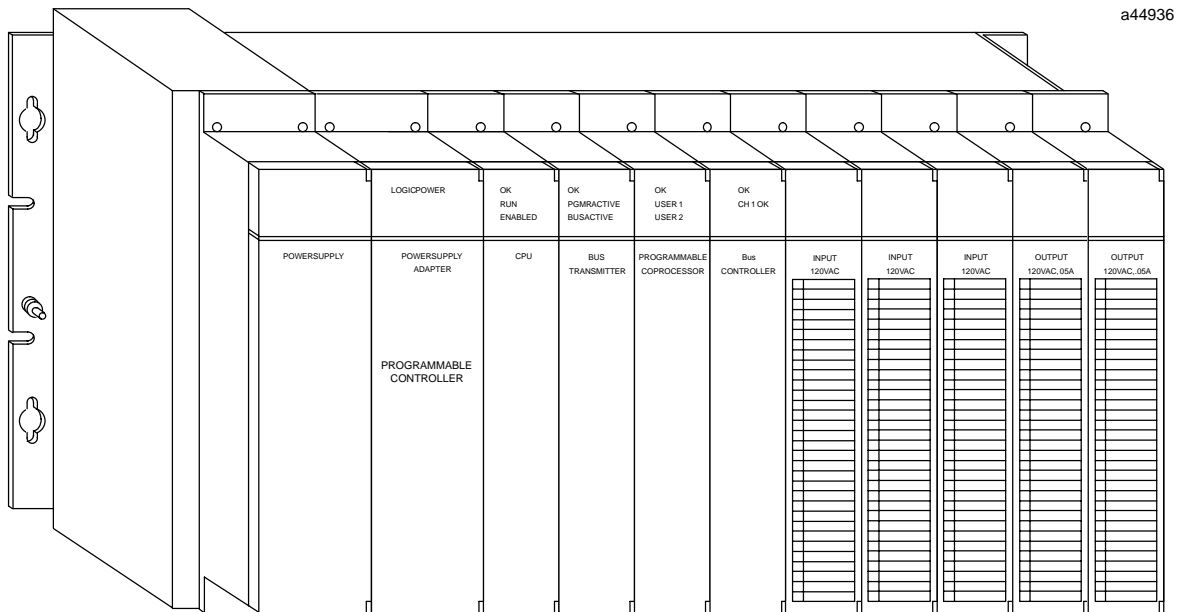

Figure 1. Location of Power Supply Adapter Module in an IC697 PLC Installation

Power Supply Adapter Module

GFK-0626D
August 1997

Table 1. Specifications for IC697PWR720 †

PowerSupply Voltage to Rack Backplane:	+5.02 to +5.12 VDC (5.07 volts nominal) +11.58 to +12.42 VDC (+12 volts nominal) -11.4 to -12.6 VDC (-12 volts nominal)
PowerSupply Current to Rack Backplane: (maximum with PSA only)	+5 VDC at 18A +12 VDC at 2A -12 VDC at 1A
Current Required from 5 V Bus	50 mA (.250W)
VME	System designed to support the VME standard C.1

† Refer to GFK-0867B, or later for product standards and general specifications. For installations requiring compliance to more stringent requirements (for example, European Union), refer to *Installation requirements for Conformance to Standards*.

Table 2. Ordering Information

Description	Catalog Number
Power Supply Adapter module	IC697PWR720
Power Supply Extension Cable (includes cable and faceplate for vacant power supply slot in second rack)	IC697CBL700

Note: For Low Temperature Testing option please consult the factory for price and availability.

GFK-0159J
August 1997

12 MHz, 32 Kbyte Central Processing Unit

Features

- Single slot CPU.
- 512 inputs and outputs (any mix).
- Up to 8K analog I/O.
- 0.4 microseconds per boolean function.
- 12 MHz, 80C186 microprocessor.
- Supports IC660/IC661) and IC697I/O products
- Programmed by MS-DOS® or Windows based software products running on Windows® 95 or Windows NT® over Ethernet TCP/IP or through the SNP port.
- 32 Kbyte battery-backed CMOS memory (fixed size).
- Configurable data and program memory.
- Battery-backed calendar clock.
- Three position operation mode switch.
- Password controlled access.
- Three status LEDs.
- Software configuration (No DIP switches or jumpers to set).
- Reference information inside front door.

Functions

The CPU 731 is a single slot PLC CPU which resides in an IC697CHS PLC rack. The CPU 731 is programmed and configured by MS-DOS or Windows based programming software to perform real time control of machines, processes and material handling systems. The CPU 731 communicates with I/O and smart option modules over the rack mounted backplane (IC697CHS750, 782, 783, 790, 791) by way of the VME C.1 Standard format.

Supported option modules include IC697 LAN Interface modules, several Coprocessor modules, Bus Controller for IC660/661 I/O products, Communications modules, I/O Link Interface, and all of the IC697 family of discrete and analog I/O modules.

Module operation may be controlled by the three position switch or remotely by an attached programmer and programming software. CPU status is indicated by three green LEDs on the front of the module.

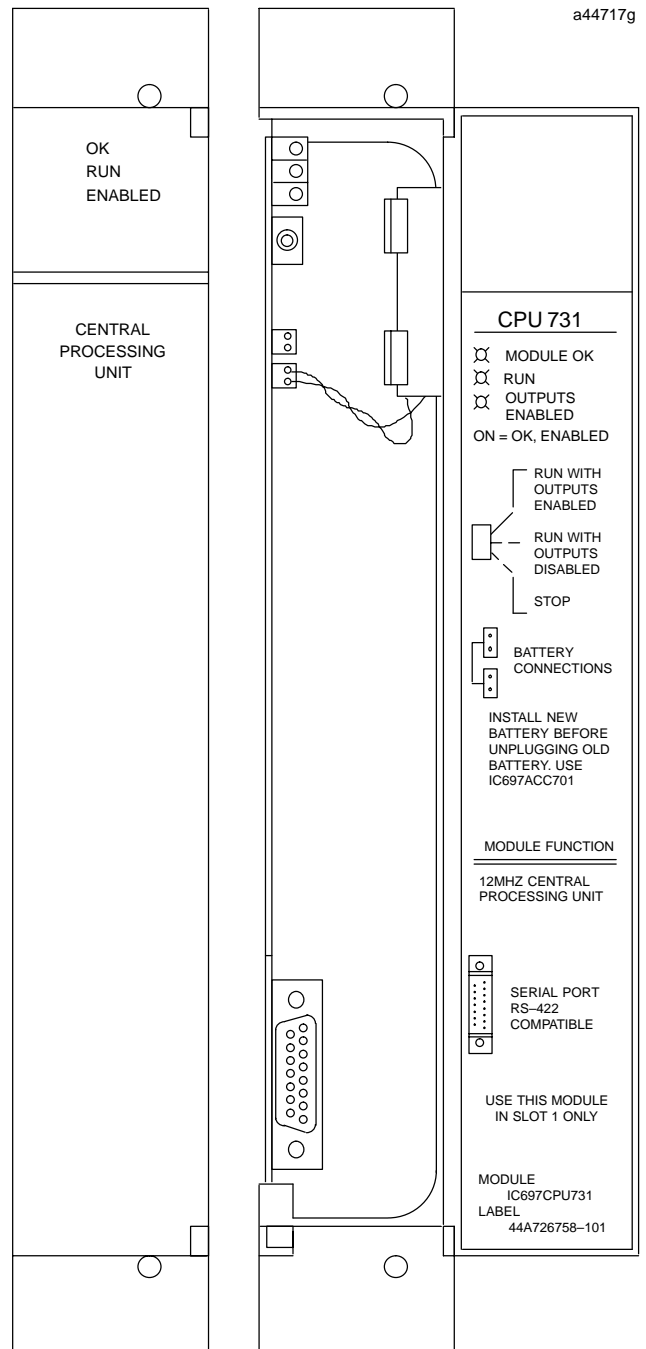

© MS-DOS, Windows, Windows 95, and Windows NT are registered trademarks of Microsoft Corporation.

GFK-0159J
August 1997

12 MHz, 32 Kbyte Central Processing Unit

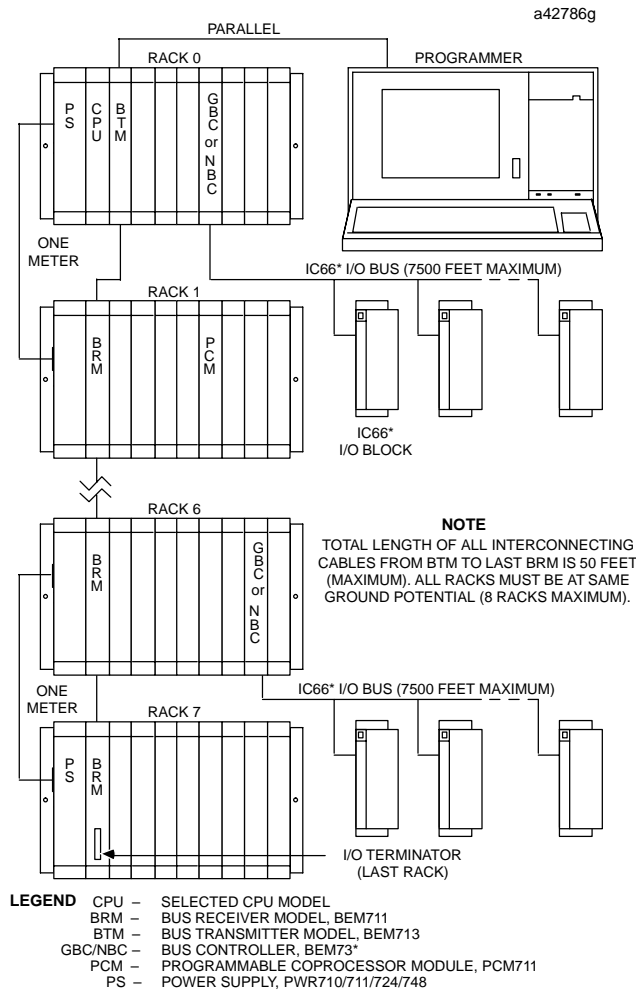

Figure 1. Typical PLC System Configuration

Installation

It is the responsibility of the OEM, system integrator, or end user to properly install the PLC equipment for safe and reliable operation. Product manuals provide detailed information about installation, startup, and proper use of the PLC equipment. The installation manual, shipped with your PLC programming software, describes how to properly install the equipment. If the PLC installation must comply with supported standards, such as FCC or CE Directives, please refer to the *Installation Requirements for Conformance to Standards*, shipped with the PLC programming software, for additional guidelines.

- Be sure that power to the PLC is turned off before installing the CPU 731 module
- Connect the battery to either of the battery connectors on the module (see Figure 2).

- Put toggle switch in the STOP position.
- Install in slot 1 of rack 0. (See Figure 1)
- Turn on power.

The module should power up and blink the top LED. When the diagnostics have completed successfully, the top LED stays on and the second and third LEDs are off. The CPU is now ready to be programmed. After the program has been verified the toggle switch may be moved to the appropriate operation mode position. The LEDs indicate the position of the toggle switch, memory protection status, and the state of the program.

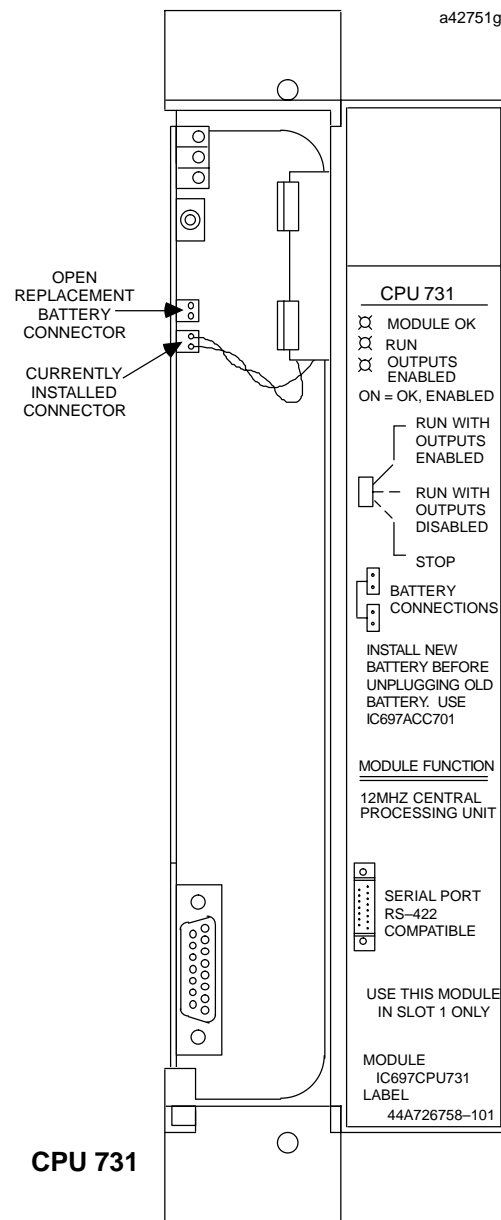

Figure 2. CPU 731- Location of Major Features

12 MHz, 32 Kbyte Central Processing Unit

GFK-0159J
August 1997

Programmer Connection, Parallel

For a parallel interface (MS-DOS programmer only) connect the programmer to the top port connector on the Bus Transmitter Module (IC697BEM713) as shown in Figure 1. Consult Reference 2 for a description of programming functions.

Serial Port

The 15-pin D-connector provides the connection to an RS-485 compatible serial port as shown in Figure 3. This port provides a serial connection to a Standard Serial COM port, or to a Work Station Interface board installed in the programming computer. For more information on serial communications, see references 1, 2, and 3.

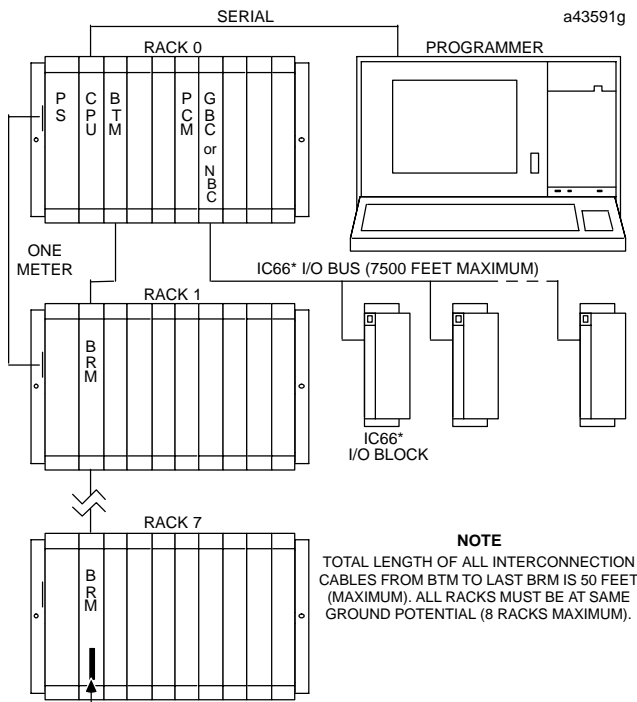

Figure 3. System Configuration, Serial Connection to Programmer

Programmer Connection, Ethernet TCP/IP

Connecting your programmer via an Ethernet TCP/IP network requires installation of an Ethernet Interface module in the PLC. This can be either the Ethernet Controller, IC697CMM741, or Ethernet Interface (Type 2), IC697CMM742. Before connecting your programmer and PLC to the Ethernet TCP/IP network you must set the IP address in the Ethernet Interface. After setting the IP address, connect the PLC and the programmer running Windows software to the Ethernet Interface. For more detailed information on the programmer connection via Ethernet TCP/IP, refer to the *TCP/IP Ethernet Communications (Type 2) User's Manual*, and the Windows programming manual, GFK-1295.

Configuration

The IC697 CPU and I/O system is configured with MS-DOS or Windows based programming software. There are no DIP switches or jumpers used to configure the system. The CPU verifies the actual module and rack configuration at power-up and periodically during operation. The actual configuration must be the same as the programmed configuration. Deviations are reported to the CPU alarm processor function for configured fault response. Consult Reference 1 for a description of configuration functions.

Batteries

A lithium battery (IC697ACC701) is installed as shown in Figure 2. This battery maintains program and data memory when power is removed and operates the calendar clock. Be sure to install the new battery before removing the old battery. If during power-up diagnostics a low battery is detected the Module OK LED (top) will not stay on. Specific indication of a low battery state is detailed in Reference 2.

GFK-0159J
August 1997

12 MHz, 32 Kbyte Central Processing Unit

Removing a Module

The following instructions should be followed when removing a module from its slot in a rack.

- Grasp the board firmly at the top and bottom of the board cover with your thumbs on the front of the cover and your fingers on the plastic clips on the back of the cover.
- Squeeze the rack clips on the back of the cover with your fingers to disengage the clip from the rack rail and pull the board firmly to remove it from the backplane connector.
- Slide the board along the card guide and remove it from the rack.

Table 1. Specifications for IC697CPU731 †

Battery ShelfLife	10 years at 20° C (68° F)
Memory Retention	6 months nominal without applied power
Current required from 5V Bus	1.0Amp
Time of Day Clock (internal timing) Accuracy	± 3.5 seconds per day
Elapsed Time Clock	± .01% maximum
Serial Port	RS422/485 compatible, programmer serial attachment
VME	System designed to support the VME standard C.1

† Refer to GFK-0867B, or later for product standards and general specifications.

Table 2. References

Reference	Title
1	Programming Software User 's Manual
2	Programmable Controller Reference Manual
3	Programmable Controller Installation Manual

Table 3. Ordering Information

Description	Catalog Number
Central processing Unit, 12 MHz, 32 Kbyte, Fixed	IC697CPU731
Lithium Battery	IC697ACC701

Note: For Conformal Coat option, or Low Temperature Testing option please consult the factory for price and availability.

GFK-0349F
August 1997

12 MHz, Expandable Central Processing Unit

Features

- Single slot CPU
- 2K inputs and outputs (any mix)
- Up to 8K analog I/O
- 0.4 microseconds per boolean function
- 12Mhz, 80C186 microprocessor
- Supports IC660/IC661 and IC697 PLC
- Programmed by MS-DOS® or Windows based software products running on Windows® 95 or Windows NT® over Ethernet TCP/IP or through the SNP port.
- Supports up to 512 Kbytes of battery-backed expansion memory in the same slot
- Configurable data and program memory
- Battery-backed calendar clock
- Three position operation mode switch
- Password controlled access
- Three Status LEDs
- Software Configuration (No DIP switches or jumpers)
- Reference information inside front door.

Functions

The CPU 771 is a single slot PLC CPU which is programmed and configured by MS-DOS or Windows based programming software to perform real time control of machines, processes and material handling systems.

The CPU 771 CPU communicates with I/O and smart option modules over the rack-mounted backplane (IC697CHS750, 782, 783, 790, 791) by way of the VME C.1 Standard format.

Supported option modules include all IC697 LAN interface modules, several Coprocessor modules, Bus Controller for IC660/661 I/O and Communications modules, in addition to all of the IC697 family of discrete and analog I/O modules (see the applicable *Programmable Controller Installation Manual* for more information on supported modules).

Program and data memory is available by the attachment of an expansion memory board with up to 512 Kbytes of battery-backed CMOS RAM.

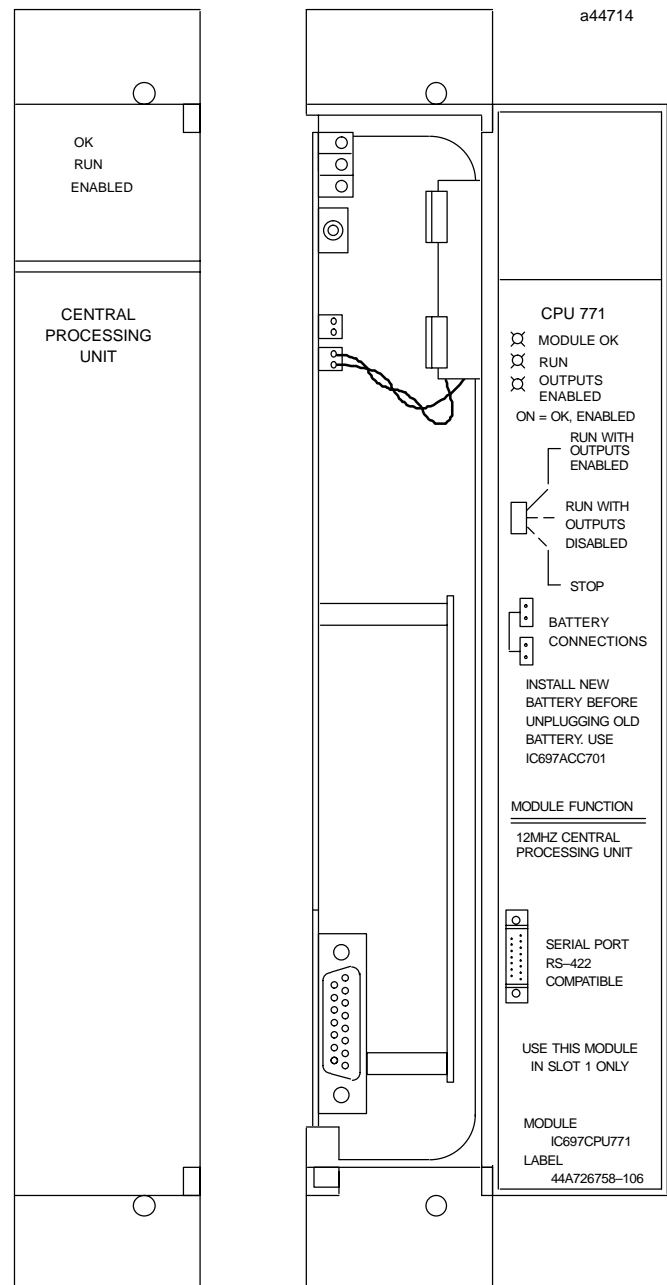

© MS-DOS, Windows, Windows 95, and Windows NT are registered trademarks of Microsoft Corporation.

GFK-0349F
August 1997

Operation of this module may be controlled by the three position switch on the module or remotely by an attached programmer and programming software. CPU status is indicated by three green LEDs on the front of the module.

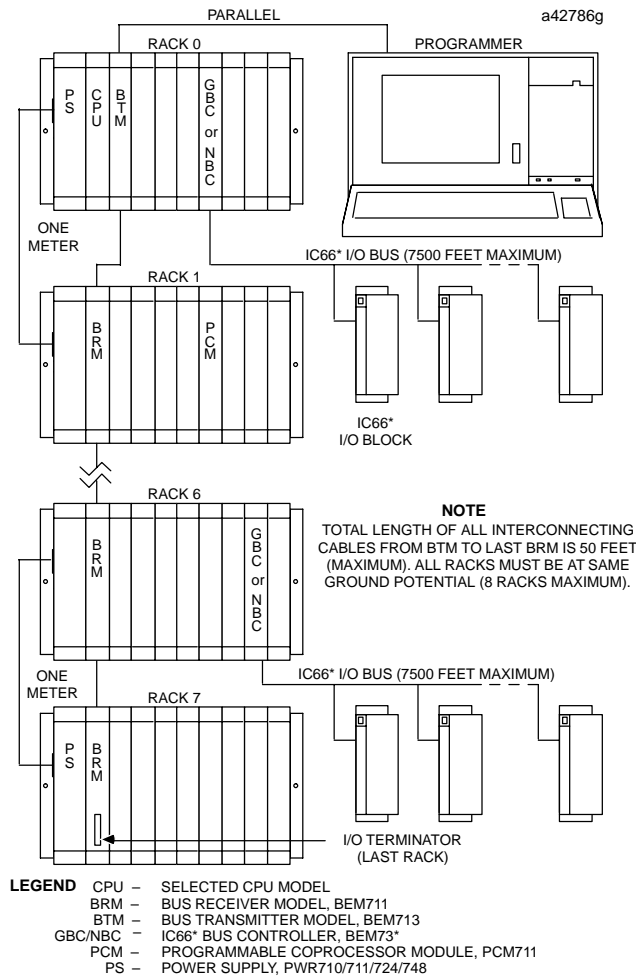

Figure 1. Typical PLC System Configuration

Installation

It is the responsibility of the OEM, system integrator, or end user to properly install the PLC equipment for safe and reliable operation. Product manuals provide detailed information about installation, startup, and proper use of the PLC equipment. The installation

12 MHz, Expandable Central Processing Unit

manual, shipped with your PLC programming software, describes how to properly install the equipment. If the PLC installation must comply with supported standards, such as FCC or CE Directives, please refer to the *Installation Requirements for Conformance to Standards*, shipped with the PLC programming software, for additional guidelines.

- Installation should not be attempted without referring to the applicable *Programmer Controller Installation Manual* (See reference 5).
- Make sure rack power is off.
- Install expansion memory.
- Connect the battery to either of the battery connectors on the module.
- Put toggle switch in Stop position.
- Install in slot 1 of rack 0. (See figure 1)
- Turn on power.

The module should power up and blink the top LED. When the diagnostics have completed successfully the top LED stays on and the middle and bottom LEDs are off. The CPU is now ready to be programmed. After the program has been verified the toggle switch may be moved to the appropriate operation mode position. The LEDs indicate the position of the toggle switch and the state of the program.

Expansion Memory

The CPU 771 must have a CMOS expansion memory board. The CMOS expansion memory board provides CMOS RAM memory of 64, 128, 256 or 512 Kbytes. The battery which supports this memory is located on the main CPU board housing. (See figure 2)

Installation of a CMOS expansion memory board on the CPU will require initialization of the CPU with the programmer (See reference 1).

Programmer Connection, Parallel

For a parallel interface (MS-DOS programmer only) the programmer is connected to the top port on the Bus Transmitter Module (IC697BEM713) as shown in Figure 1. Consult Reference 1 for a description of programming functions.

12 MHz, Expandable Central Processing Unit

GFK-0349F
August 1997

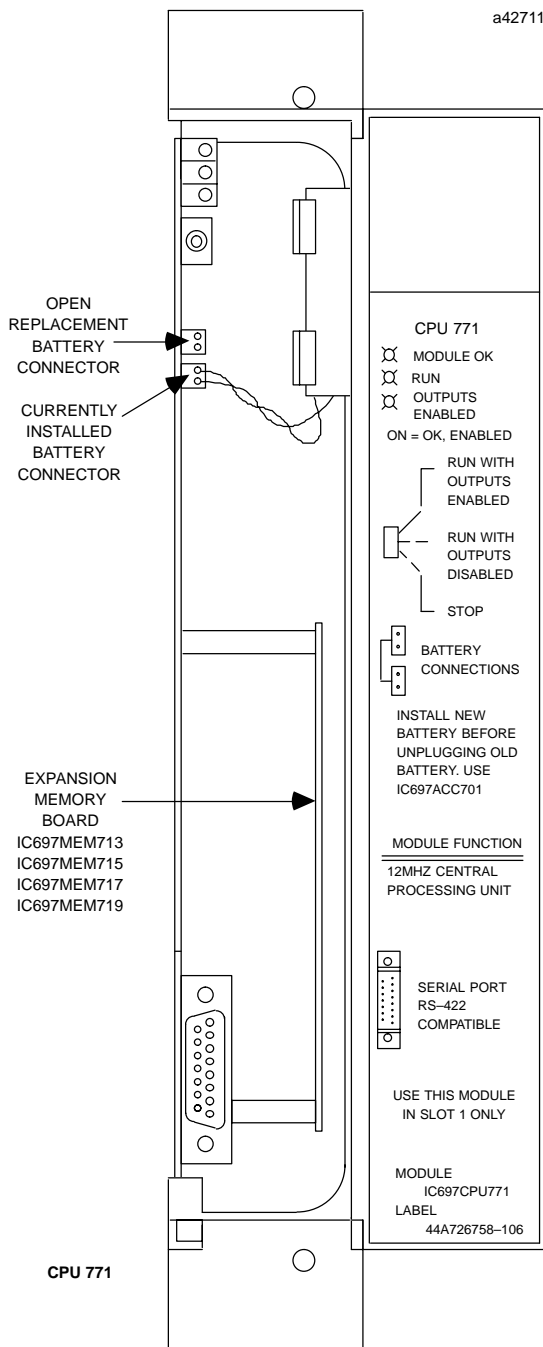

Figure 2. CPU 771 - Location of Major Features

Serial Port

The 15-pin D-connector provides the connection to an RS-485 compatible serial port as shown in Figure 3.

This port provides a serial connection to a Work Station Interface board installed in the programming computer.

The serial connection can also be made from the serial port on the CPU to the serial port on the programming computer, or other serial device, through the RS-422/RS-485 to RS-232 Converter (IC690ACC900) or RS-232 to RS-422 Miniconverter (IC690ACC901). This connection can be made with available cables or you may build cables to fit the needs of your application.

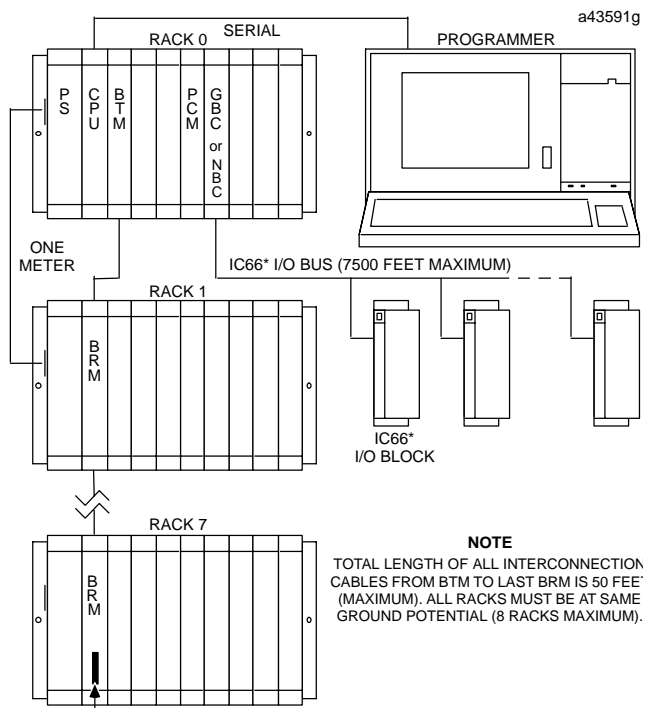

Figure 3. System Configuration, Serial Connection to Programmer

Programmer Connection, Ethernet TCP/IP

Connecting your programmer via an Ethernet TCP/IP network requires installation of an Ethernet Interface module in the PLC. This can be either the Ethernet Controller, IC697CMM741, or Ethernet Interface (Type 2), IC697CMM742. Before connecting your programmer and PLC to the Ethernet TCP/IP network you must set the IP address in the Ethernet Interface. After setting the IP address, connect the PLC and the programmer running Windows software to the Ethernet Interface. For more detailed information on Ethernet TCP/IP, refer to the *TCP/IP Ethernet Communications (Type 2) User's Manual*, and the Windows programming manual, GFK-1295.

GFK-0349F
August 1997

12 MHz, Expandable Central Processing Unit

Configuration

The IC697 CPU and I/O system is configured with MS-DOS or Windows based programming software. There are no DIP switches or jumpers used to configure the system. The CPU verifies the actual module and rack configuration at power-up and periodically during operation. The actual configuration must be the same as the programmed configuration. Deviations are reported to the CPU alarm processor function for configured fault response.

Batteries

A lithium battery (IC697ACC701) is installed as shown in figure 2. This battery maintains program and data memory when power is removed and operates the calendar clock. Be sure to install the new battery before removing the old battery.

If during power-up diagnostics a low battery is detected the Module OK LED (top) will not stay on. Specific indication of a low battery state is detailed in Reference 2.

Removing a Module

The instructions below should be followed when removing a module from its slot in a rack.

- Grasp the board firmly at the top and bottom of the board cover with your thumbs on the front of the cover and your fingers on the plastic clips on the back of the cover.
- Squeeze the rack clips on the back of the cover with your fingers to disengage the clip from the rack rail and pull the board firmly to remove it from the backplane connector.
- Slide the board along the card guide and remove it from the rack.

Table 1. References

Reference	Title
1	Programming Software User's Manual
2	Programmable Controller Reference Manual
5	Programmable Controller Installation Manual

Table 2. Specifications for IC697CPU771 †

Battery	
Shelflife	10 years at 20°C (68°F)
Memory retention	6 months nominal without applied power.
Current Required from 5V Bus	1.1 Amps with Expansion Memory (all sizes) 1.2 Amps
Time of Day Clock accuracy	" 3.5 seconds per day maximum
Elapsed Time Clock (internal timing) accuracy	" .01% maximum
Serial Port	
RS422 compatible	Serial connection to programmer
VME	System designed to support the VME standard C.1

† Refer to GFK-0867B, or later for product standards and general specifications.

Table 3. Ordering Information

Description	Catalog Number
CPU, 12 Mhz, Expandable	IC697CPU771
64 Kbyte CMOS Expansion Memory	IC697MEM713
128 Kbyte CMOS Expansion Memory	IC697MEM715
256 Kbyte CMOS Expansion Memory	IC697MEM717
512 Kbyte CMOS Expansion Memory	IC697MEM719
Lithium Battery	IC697ACC701

Note: For Conformal Coat option, or Low Temperature Testing option please consult the factory for price and availability.

GFK-0588E
August 1997

12 MHz Expandable, Floating Point Central Processing Unit

Features

- Supports floating point calculations.
- Single slot CPU.
- 2K inputs and outputs (any mix).
- Up to 8K analog I/O.
- 0.4 microseconds per boolean function.
- 12 MHz, 80C186 microprocessor.
- Supports IC660/IC661 and IC697I/O.
- Programmed by MS-DOS® or Windows based software products running on Windows® 95 or Windows NT® over Ethernet TCP/IP or through the SNP port.
- Supports up to 512 Kbytes of battery-backed expansion memory in the same slot.
- Configurable data and program memory.
- Battery-backed calendar clock.
- Three position operation mode switch.
- Password controlled access.
- Three status LEDs.
- Software configuration (No DIP switches or jumpers to set).
- Reference information inside front door.

Functions

The CPU 772 is a single slot PLC CPU which allows floating point calculations. The CPU 772 is programmed and configured by MS-DOS or Windows based programming software to perform real time control of machines, processes and material handling systems. The CPU 772 communicates with I/O and smart option modules over the rack mounted backplane (IC697CHS750, 782, 783, 790, 791) by way of the VME C.1 Standard format.

Supported option modules include IC697 LAN interface modules, several Coprocessor modules, Bus Controller for IC660/IC661 I/O products, Communications modules, I/O Link Interface, and all of the IC697 family of discrete and analog I/O modules (see the applicable

Programmable Controller Installation Manual for more information on supported modules).

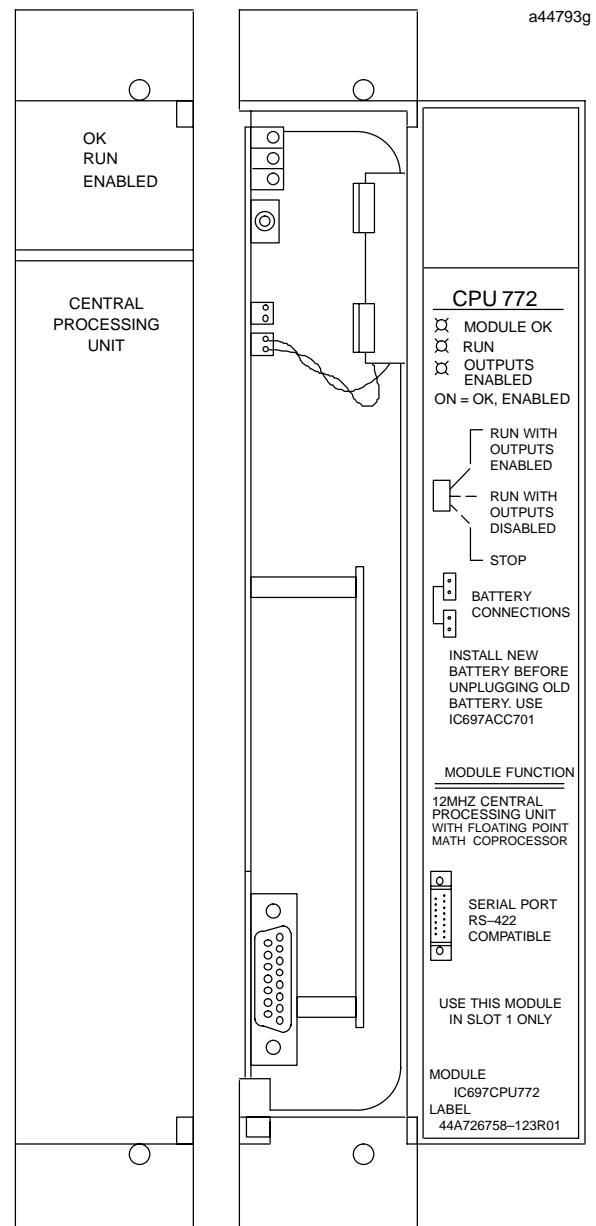

© MS-DOS, Windows, Windows 95, and Windows NT are registered trademarks of Microsoft Corporation.

GFK-0588E
August 1997

12 MHz Expandable, Floating Point Central Processing Unit

Program and data memory for the CPU 772 is available by attachment of an expansion memory board with either 64, 128, 256 or 512 Kbytes of battery-backed CMOS RAM.

Operation of this module may be controlled by the three position switch or remotely by an attached programmer and programming software. CPU status is indicated by three green LEDs on the front of the module.

and reliable operation. Product manuals provide detailed information about installation, startup, and proper use of the PLC equipment. The installation manual, shipped with your PLC programming software, describes how to properly install the equipment. If the PLC installation must comply with supported standards, such as FCC or CE Directives, please refer to the *Installation Requirements for Conformance to Standards*, shipped with the PLC programming software, for additional guidelines.

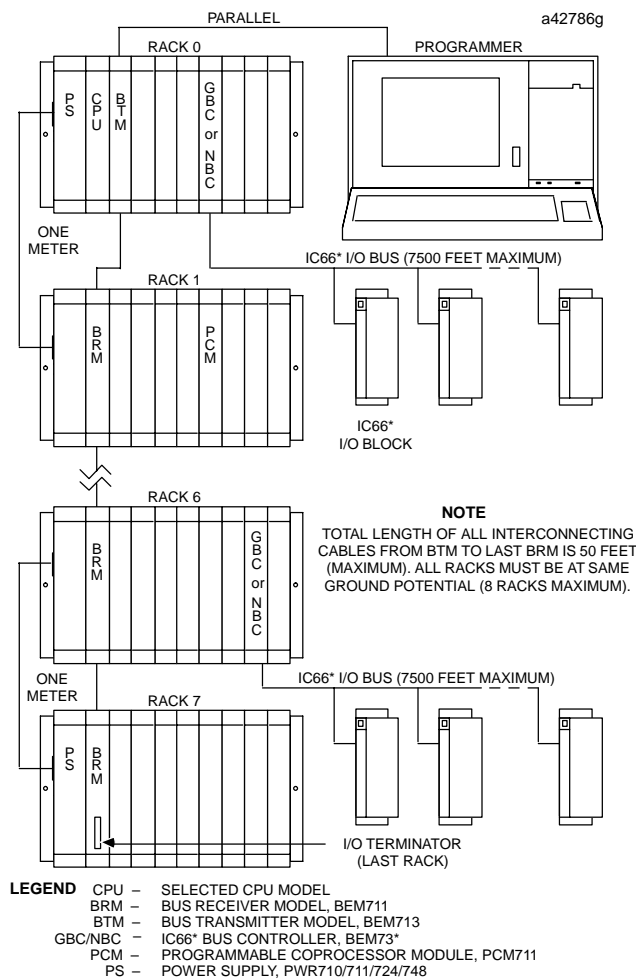

Figure 1. Typical PLC System Diagram

Installation

It is the responsibility of the OEM, system integrator, or end user to properly install the PLC equipment for safe

- Installation should not be attempted without referring to the applicable programmable controller hardware installation manual.
- Be sure that power to the PLC is turned off before installing the CPU 772 module
- Align the captive screws on the memory board with the standoffs already installed on the CPU.
- Push the memory board onto the CPU connector ensuring that the mating screws remain aligned with their respective standoff.
- Screw each memory board screw into the standoffs with a #1 Phillips screwdriver, and tighten.
- Connect the battery to either of the battery connectors on the module.
- Put toggle switch in the STOP position.
- Install in slot 1 of rack 0. (See Figure 1)
- Turn on power.

The module should power up and blink the top LED. When the diagnostics have completed successfully, the top LED stays on and the second and third LEDs are off. The fourth LED is off if the keyswitch is in the OFF position. The CPU is now ready to be programmed (if connected parallel, the CPU can be programmed regardless of key position). After the program has been verified the toggle switch may be moved to the appropriate operation mode position. The LEDs indicate the position of the toggle switch, memory protection status, and the state of the program.

Expansion Memory

The CPU 772 must have a CMOS RAM expansion memory board which provides CMOS RAM memory of 64K, 128K, 256K or 512 Kbytes. The battery which supports this memory is located on the main CPU board (see Figure 2). Installation of a CMOS expansion memory board on the CPU will require initialization of the CPU with the programmer (see Reference 2).

12 MHz Expandable, Floating Point Central Processing Unit

GFK-0588E
August 1997

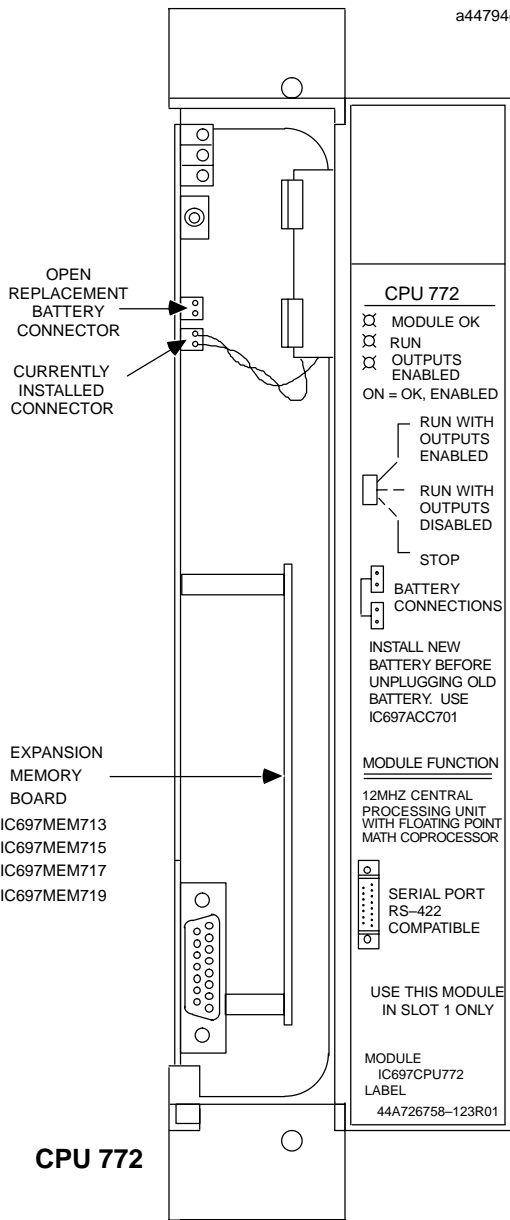

Figure 2. CPU 772 - Location of Major Features

Programmer Connection, Parallel

For a parallel interface (MS-DOS programmer only) the programmer is connected to the top port connector on the Bus Transmitter Module (IC697BEM713) as shown in Figure 1. Consult Reference 2 for a description of programming functions.

Serial Port

The 15-pin D-connector provides the connection to an RS-485 compatible serial port as shown in Figure 3. This port provides a serial connection to a Standard Serial COM port, or to a Work Station Interface board installed in the programming computer.

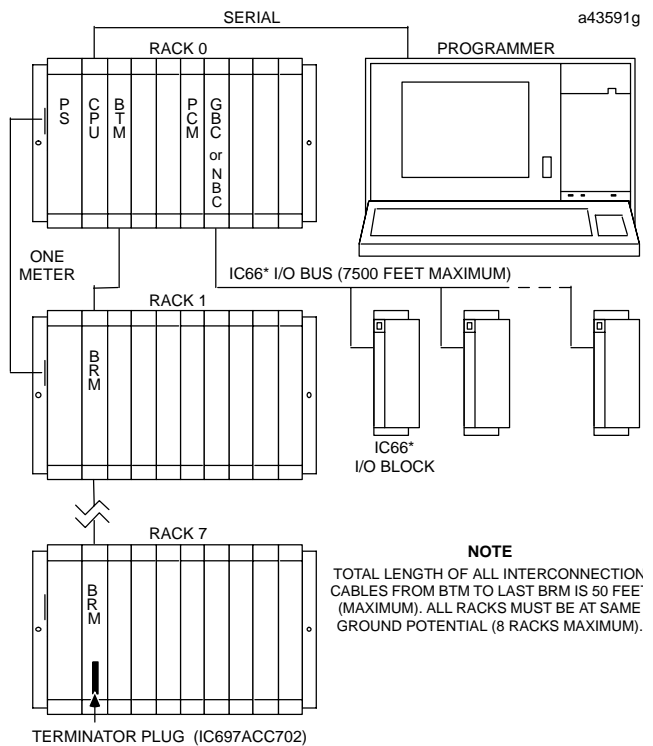

Figure 3. System Configuration, Serial Connection to Programmer

Programmer Connection, Ethernet TCP/IP

Connecting your programmer via an Ethernet TCP/IP network requires installation of an Ethernet Interface module in the PLC. This can be either the Ethernet Controller, IC697CMM741, or Ethernet Interface (Type 2), IC697CMM742. Before connecting your programmer and PLC to the Ethernet TCP/IP network you must set the IP address in the Ethernet Interface. After setting the IP address, connect the PLC and the programmer running Windows software to the Ethernet Interface. For more detailed information on Ethernet TCP/IP, refer to the *TCP/IP Ethernet Communications (Type 2) User's Manual*, and the Windows programming manual, GFK-1295.

GFK-0588E
August 1997

12 MHz Expandable, Floating Point Central Processing Unit

Configuration

The IC697 CPU and I/O system is configured with MS-DOS or Windows based programming software. There are no DIP switches or jumpers used to configure the system. The CPU verifies the actual module and rack configuration at power-up and periodically during operation. The actual configuration must be the same as the programmed configuration. Deviations are reported to the CPU alarm processor function for configured fault response. Consult Reference 1 for a description of configuration functions.

Batteries

A lithium battery (IC697ACC701) is installed as shown in Figure 2. This battery maintains program and data memory when power is removed and operates the calendar clock. Be sure to install the new battery be-

fore removing the old battery. If during power-up diagnostics a low battery is detected the Module OK LED (top) will not stay on. Specific indication of a low battery state is detailed in Reference 3.

Removing a Module

The following instructions should be followed when removing a module from its slot in a rack.

- Grasp the board firmly at the top and bottom of the board cover with your thumbs on the front of the cover and your fingers on the plastic clips on the back of the cover.
- Squeeze the rack clips on the back of the cover with your fingers to disengage the clip from the rack rail and pull the board firmly to remove it from the backplane connector.
- Slide the board along the card guide and remove it from the rack.

Table 1. Specifications for IC697CPU772 †

Battery ShelfLife	10 years at 20° C (68° F)
Memory Retention	6 months nominal without applied power
Current required from 5V Bus	1.2 Amps (includes expansion memory)
Time of Day Clock (internal timing) Accuracy	± 3.5 seconds per day
Elapsed Time Clock	± .01% maximum
Serial Port	RS422/485compatible,Programmer Serial Attachment
VME	System designed to support the VME standard C.1

† Refer to GFK-0867B, or later for product standards and general specifications.

Table 2. References

Reference	Title
1	ProgrammingSoftwareUser's Manual
2	ProgrammableControllerReference Manual
3	ProgrammableControllerInstallationManual

Table 3. Ordering Information

Description	Catalog Number
CPU 772, 16 MHz, Expandable, Floating Point	IC697CPU772
64 Kbyte, CMOS Expansion Memory	IC697MEM713
128 Kbyte, CMOS Expansion Memory	IC697MEM715
256 Kbyte, CMOS Expansion Memory	IC697MEM717
512 Kbyte, CMOS Expansion Memory	IC697MEM719
LithiumBattery	IC697ACC701

Note: For Conformal Coat option, or Low Temperature Testing option please consult the factory for price and availability.

GFK-0766D
August 1997

16 MHz, 32-Bit, Expandable Central Processing Unit

Features

- Single slot CPU.
- 12K inputs and outputs (any mix).
- Up to 8K analog I/O.
- 0.4 microseconds per boolean function.
- 16 MHz, 80386DX microprocessor.
- Supports IC660/IC661 and IC697 I/O products.
- Programmed by MS-DOS® or Windows® software products running on Windows® 95 or Windows NT® over Ethernet TCP/IP or through the SNP port.
- Supports up to 512 Kbytes of battery-backed expansion memory in the same slot.
- Configurable data and program memory.
- Battery-backed calendar clock.
- Three position operation mode switch.
- Password controlled access.
- Keyswitch memory protection
- Four status LEDs.
- Software configuration (No DIP switches or jumpers to set).
- Reference information inside front door.

Functions

The CPU 781 is a single slot programmable controller CPU which is programmed and configured by MS-DOS or Windows based programming software to perform real time control of machines, processes and material handling systems.

The CPU 781 communicates with I/O and smart option modules over the rack mounted backplane (IC697CHS750, 782, 783, 790, 791) by way of the VME C.1 Standard format.

Supported option modules include all IC697 LAN interface modules, several Coprocessor modules, Bus Controller for IC660/IC661 I/O, Communications modules, and all of the IC697 family of discrete and analog I/O modules (see the applicable *Programmable Controller Installation Manual* for more information on supported modules).

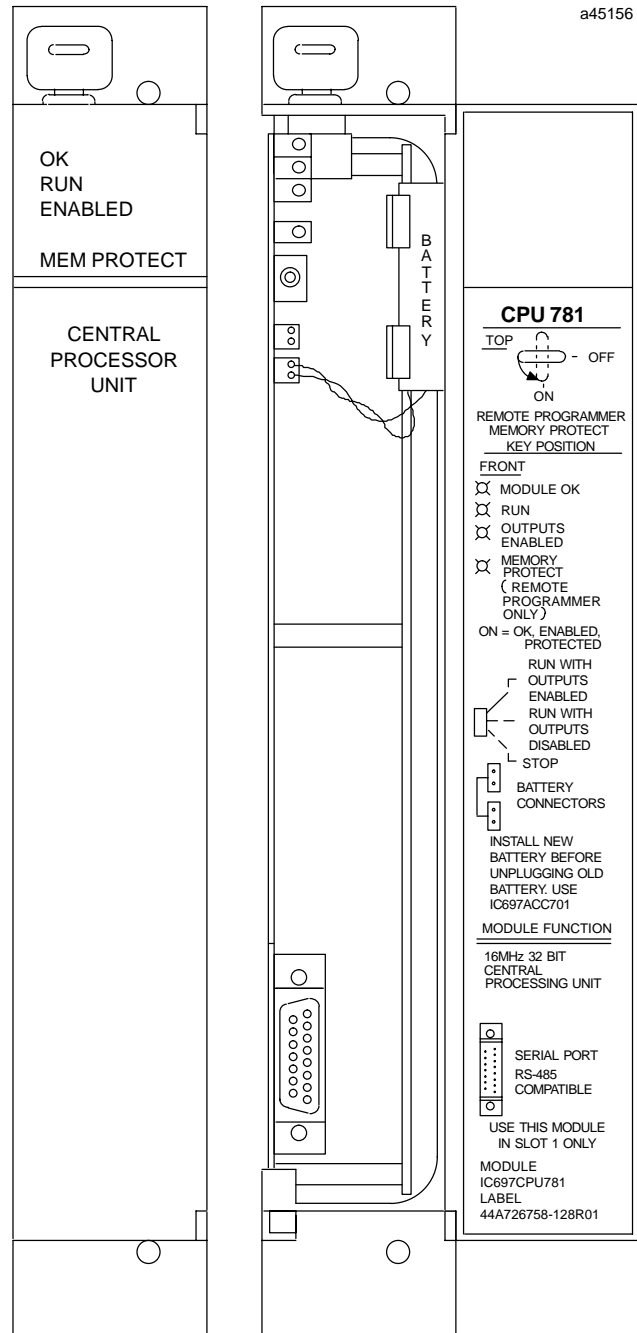

Program and data memory for the CPU 781 is available by the attachment of an expansion memory board with either 128, 256 or 512 KBytes of battery-backed CMOS RAM, or 256 KBytes w/256 KBytes of Non-volatile flash.

© MS-DOS, Windows, Windows 95, and Windows NT are registered trademarks of Microsoft Corporation.

GFK-0766D
August 1997

16 MHz, 32-Bit, Expandable Central Processing Unit

Operation of this module may be controlled by the three position RUN/STOP switch or remotely by an attached programmer and programming software. Program and configuration data can be locked through software passwords or manually by the memory protect keyswitch. When the key is in the *protected* position, program and configuration data can only be changed by a programmer connected parallel only (i.e., via the Bus Transmitter module). The status of the CPU is indicated by the four green LEDs on the front of the module.

detailed information about installation, startup, and proper use of the PLC equipment. The installation manual, shipped with your PLC programming software, describes how to properly install the equipment. If the PLC installation must comply with supported standards, such as FCC or CE Directives, please refer to the *Installation Requirements for Conformance to Standards*, shipped with the PLC programming software, for additional guidelines.

Installation should not be attempted without referring to the applicable hardware installation manual.

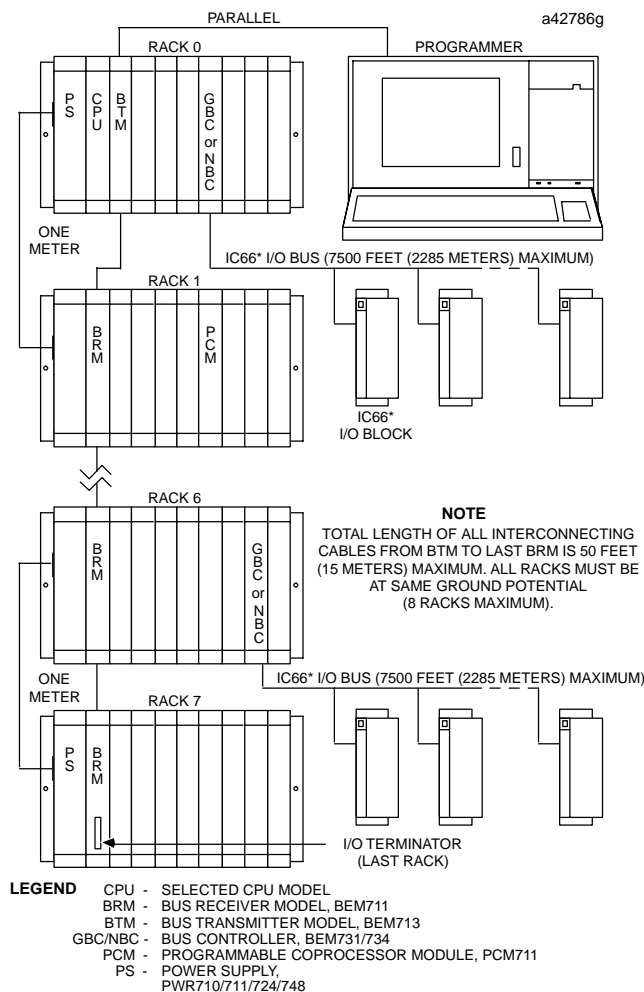

Figure 1. Typical PLC System Diagram

Installation

It is the responsibility of the OEM, system integrator, or end user to properly install the PLC equipment for safe and reliable operation. Product manuals provide

- Align the expansion memory and CPU connectors.
- Align the captive screws on the memory board with the standoffs already installed on the CPU.
- Push the memory board onto the CPU connector ensuring that the mating screws remain aligned with their respective standoff.
- Screw each memory board screw into the standoffs with a #1 Phillips screwdriver, and tighten.
- Connect the battery to either of the battery connectors on the module.
- Put toggle switch in the STOP position.
- Put keyswitch in Memory Protection OFF position.
- Make sure rack power is off.
- Install in slot 1 of rack 0. (See Figure 1)
- Turn on power.

The module should power up and blink the top LED. When the diagnostics have completed successfully, the top LED stays on and the second and third LEDs are off. The fourth LED is off if the keyswitch is in the OFF position. The CPU is now ready to be programmed. After the program has been verified the toggle switch may be moved to the appropriate operation mode position. The LEDs indicate the position of the toggle switch, memory protection status, and the state of the program.

Expansion Memory

The CPU 781 must have a CMOS expansion memory board. Expansion memory boards are available with 128 KBytes, 256 KBytes, 512 KBytes, and 256 KBytes with 256 KBytes of non-volatile Flash memory. The battery which supports the CMOS RAM memory is located on the main CPU board. (See Figure 2).

Installation of an expansion memory board on the CPU will require initialization of the CPU with the programmer (See Reference 2).

16 MHz, 32-Bit, Expandable Central Processing Unit

GFK-0766D
August 1997

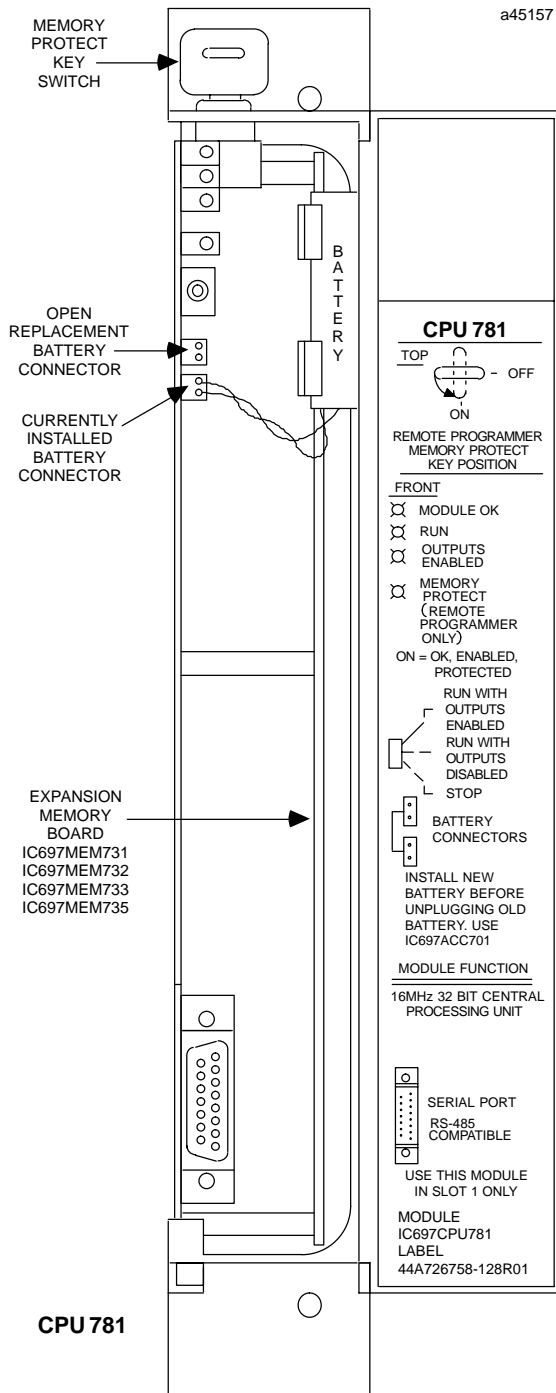

Figure 2. CPU 781 - Location of Major Features

Programmer Connection, Parallel

The programmer connects to the top port on the bus transmitter (IC697BEM713) system interface module for a parallel interface (MS-DOS programmer only), see Figure 1. Consult Reference 2 for a description of programming functions.

Serial Port

The 15-pin D-connector provides the connection to an RS-485 compatible serial port as shown in Figure 3. This port provides a serial connection to an IC647 communications interface board installed in the programming computer.

The serial connection can also be made from the Standard Serial COM port on the CPU to the serial port on the programming computer, or other serial device, through the RS-422/RS-485 to RS-232 Converter (IC690ACC900) or RS-232 to RS-422 Miniconverter (IC690ACC901). This connection can be made with available cables or you may build cables to fit the needs of your particular application. For more information on serial communications, see Reference 3.

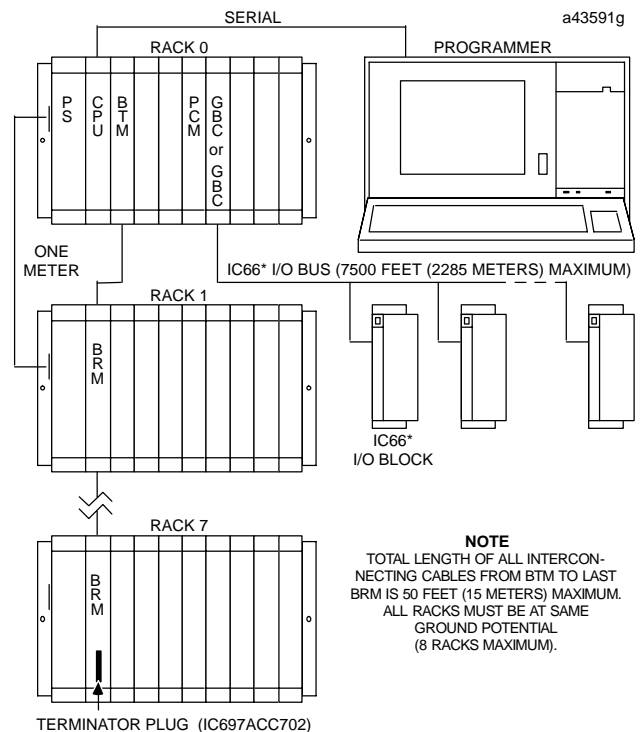

Figure 3. System Configuration, Serial Connection to Programmer

GFK-0766D
August 1997

16 MHz, 32-Bit, Expandable Central Processing Unit

Programmer Connection, Ethernet TCP/IP

Connecting your programmer via an Ethernet TCP/IP network requires installation of an Ethernet Interface module in the PLC. This can be either the Ethernet Controller, IC697CMM741, or Ethernet Interface (Type 2), IC697CMM742. Before connecting your programmer and PLC to the Ethernet TCP/IP network you must set the IP address in the Ethernet Interface. After setting the IP address, connect the PLC and the programmer running Windows software to the Ethernet Interface. For more detailed information on Ethernet TCP/IP, refer to the *TCP/IP Ethernet Communications (Type 2) User's Manual*, and the Windows programming manual, GFK-1295.

Configuration

The IC697 CPU and I/O system is configured with MS-DOS or Windows based programming software. There are no DIP switches or jumpers used to configure the system. The CPU verifies the actual module and rack configuration at power-up and periodically during operation. The actual configuration must be the same as the programmed configuration. Deviations are reported to the CPU alarm processor func-

tion for configured fault response. Consult Reference 1 for a description of configuration functions.

Batteries

A lithium battery (IC697ACC701) is installed as shown in Figure 2. This battery maintains program and data memory when power is removed and operates the calendar clock. Be sure to install the new battery before removing the old battery. If during power-up diagnostics a low battery is detected the Module OK LED (top) will not stay on. Specific indication of a low battery state is detailed in Reference 2.

Removing a Module

The following instructions should be followed when removing a module from its slot in a rack.

- Grasp the board firmly at the top and bottom of the board cover with your thumbs on the front of the cover and your fingers on the plastic clips on the back of the cover.
- Squeeze the rack clips on the back of the cover with your fingers to disengage the clip from the rack rail and pull the board firmly to remove it from the backplane connector.
- Slide the board along the card guide and remove it from the rack.

Table 1. Specifications for IC697CPU781 †

Battery ShelfLife	10 years at 20° C (68° F)
Memory Retention	6 months nominal without applied power
Current required from 5V Bus	1.6 Amps (includes expansion memory)
Time of Day Clock (internal timing) Accuracy	±3.5 seconds per day
Elapsed Time Clock	±.01% maximum
Serial Port	RS422/485compatible,Programmer Serial Attachment
VME	System designed to support the VME standard C.1

† Refer to GFK-0867B, or later for product standards and general specifications.

Table 2. References

Reference	Title
1	ProgrammingSoftwareUser'sManual
2	ProgrammableControllerReferenceManual
3	ProgrammableControllerInstallationManual

16 MHz, 32-Bit, Expandable Central Processing UnitGFK-0766D
August 1997**Table 3. Ordering Information**

Description	Catalog Number
CPU 781, 16 MHz, 32-Bit, Expandable Memory	IC697CPU781
128 Kbyte, 32-Bit CMOS Expansion Memory	IC697MEM731
256 Kbyte with 256 KByte Non-Volatile Flash Memory, 32-Bit CMOS Expansion Memory	IC697MEM732
256 Kbyte, 32-Bit CMOS Expansion Memory	IC697MEM733
512 Kbyte, 32-Bit CMOS Expansion Memory	IC697MEM735
Lithium Battery	IC697ACC701

Note: For Conformal Coat option, or Low Temperature Testing option please consult the factory for price and availability.

GFK-0767D
August 1997

16 MHz, 32-Bit, Expandable, Floating Point Central Processing Unit

Features

- Supports floating point calculations
- Single slot CPU.
- 12K inputs and outputs (any mix).
- Up to 8K analog I/O.
- 0.4 microseconds per boolean function.
- 16MHz, 80386DX microprocessor.
- Supports IC660/IC661 and IC697I/O products.
- Programmed by MS-DOS® or Windows® software products running on Windows® 95 or Windows NT® over Ethernet TCP/IP or through the SNP port.
- Supports up to 512 Kbytes of battery-backed expansion memory in the same slot.
- Configurable data and program memory.
- Battery-backed calendar clock.
- Three position operation mode switch.
- Password controlled access.
- Keyswitch memory protection
- Four status LEDs.
- Software configuration (No DIP switches or jumpers to set).
- Reference information inside front door.

Functions

The CPU 782 is a single slot programmable controller CPU which allows floating point calculations. The CPU782 is programmed and configured by MS-DOS or Windows based programming software to perform real time control of machines, processes and material handling systems.

The CPU 782 communicates with I/O and smart option modules over the rack mounted backplane (IC697CHS750, 782, 783, 790, 791) by way of the VME C.1 Standard format.

Supported option modules include all IC697 LAN interface modules, several Coprocessor modules, Bus Controller for IC660/IC661 I/O, Communications modules, and all of the IC697 family of discrete and analog I/O modules.

© MS-DOS, Windows, Windows 95, and Windows NT are registered trademarks of Microsoft Corporation.

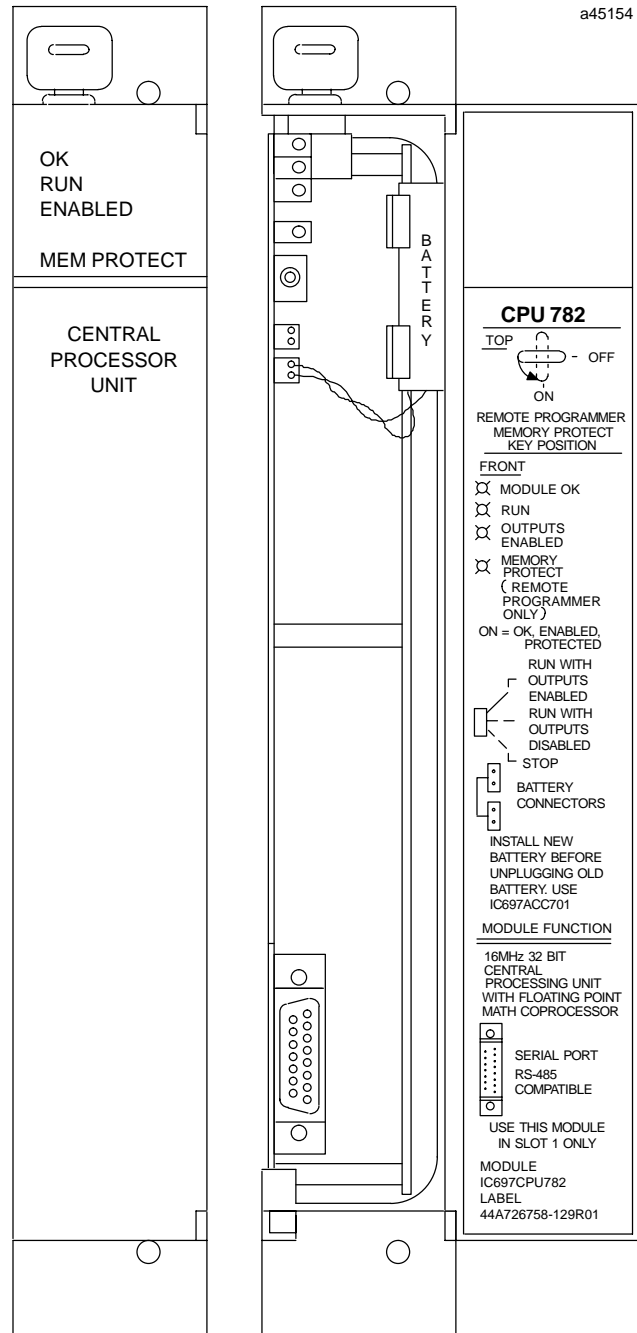

Program and data memory for the CPU 782 is available by the attachment of an expansion memory board with either 128, 256 or 512 KBytes of battery-backed CMOS RAM, or 256 KBytes w/256 KBytes of Non-volatile flash.

GFK-0767D
August 1997

16 MHz, 32-Bit, Expandable, Floating Point Central Processing Unit

Operation of this module may be controlled by the three position RUN/STOP switch or remotely by an attached programmer and programming software. Program and configuration data can be locked through software passwords or manually by the memory protect keyswitch. When the key is in the *protected* position, program and configuration data can only be changed by a programmer connected parallel only (i.e., via the Bus Transmitter module). The status of the CPU is indicated by the four green LEDs on the front of the module.

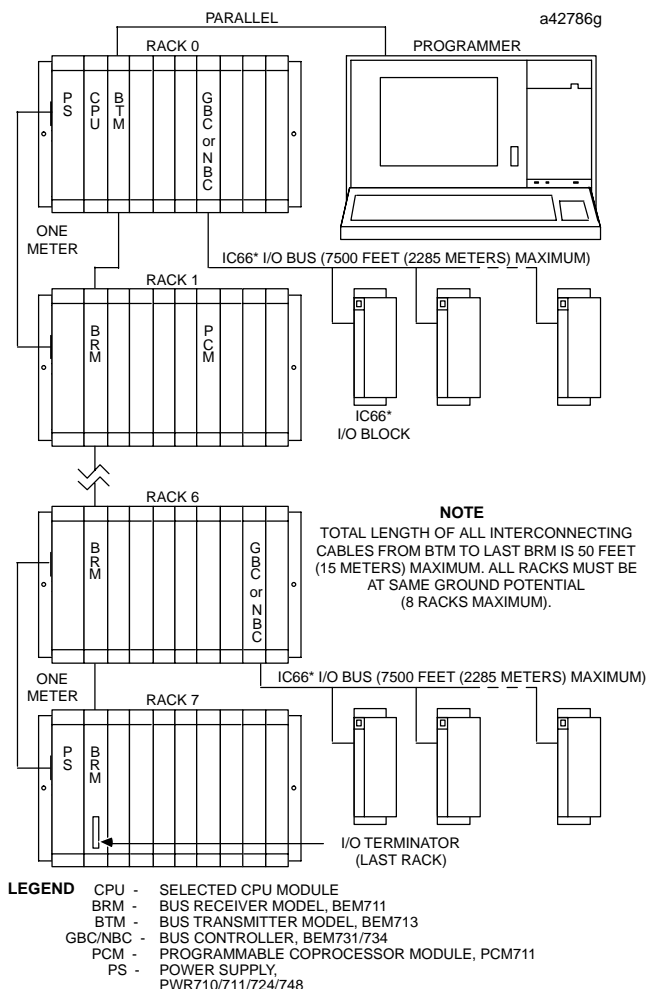

Figure 1. Typical PLC System Diagram

Installation

It is the responsibility of the OEM, system integrator, or end user to properly install the PLC equipment for safe and reliable operation. Product manuals provide detailed information about installation, startup, and

proper use of the PLC equipment. The installation manual, shipped with your PLC programming software, describes how to properly install the equipment. If the PLC installation must comply with supported standards, such as FCC or CE Directives, please refer to the *Installation Requirements for Conformance to Standards*, shipped with the PLC programming software, for additional guidelines.

Installation should not be attempted without referring to the applicable hardware installation manual.

- Align the expansion memory and CPU connectors.
- Align the captive screws on the memory board with the standoffs already installed on the CPU.
- Push the memory board onto the CPU connector ensuring that the mating screws remain aligned with their respective standoff.
- Screw each memory board screw into the standoffs with a #1 Phillips screwdriver, and tighten.
- Connect the battery to either of the battery connectors on the module.
- Put toggle switch in the STOP position.
- Put keyswitch in Memory Protection OFF position.
- Make sure rack power is off.
- Install in slot 1 of rack 0. (See Figure 1)
- Turn on power.

The module should power up and blink the top LED. When the diagnostics have completed successfully, the top LED stays on and the second and third LEDs are off.

The fourth LED is off if the keyswitch is in the OFF position. The CPU is now ready to be programmed. After the program has been verified the toggle switch may be moved to the appropriate operation mode position. The LEDs indicate the position of the toggle switch, memory protection status, and the state of the program.

Expansion Memory

The CPU 781 must have a CMOS expansion memory board. Expansion memory boards are available with 128 KBytes, 256 KBytes, 512 KBytes, and 256 KBytes with 256 KBytes non-volatile flash memory. The battery which supports the CMOS RAM memory is located on the main CPU board. (See Figure 2).

Installation of an expansion memory board on the CPU will require initialization of the CPU with the programmer (See Reference 2).

16 MHz, 32-Bit, Expandable, Floating Point Central Processing Unit

GFK-0767D
August 1997

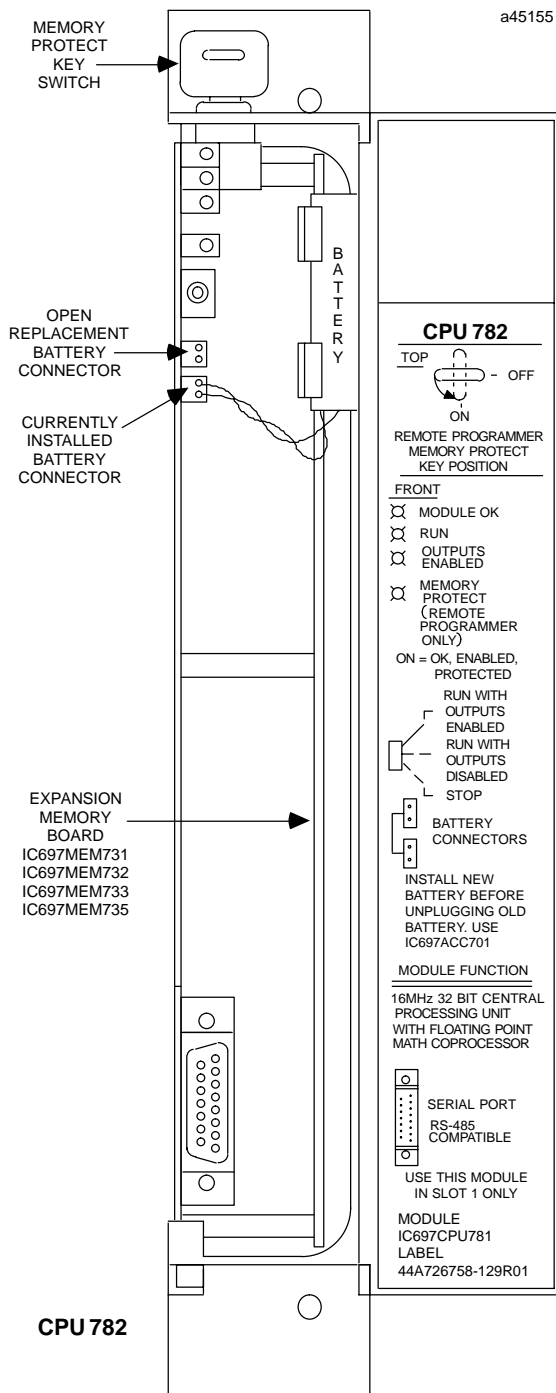

Figure 2. CPU 782 - Location of Major Features

Programmer Connection, Parallel

The programmer connects to the top port on the bus transmitter (IC697BEM713) system interface module for a parallel interface (MS-DOS programmer only), see Figure 1. Consult Reference 2 for a description of programming functions.

Serial Port

The 15-pin D-connector provides the connection to an RS-485 compatible serial port as shown in Figure 3. This port provides a serial connection to an IC647 communications interface board installed in the programming computer.

The serial connection can also be made from the Standard Serial COM port on the CPU to the serial port on the programming computer, or other serial device, through the RS-422/RS-485 to RS-232 Converter (IC690ACC900) or RS-232 to RS-422 Miniconverter (IC690ACC901). This connection can be made with available cables or you may build cables to fit the needs of your particular application. For more information on serial communications, see Reference 3.

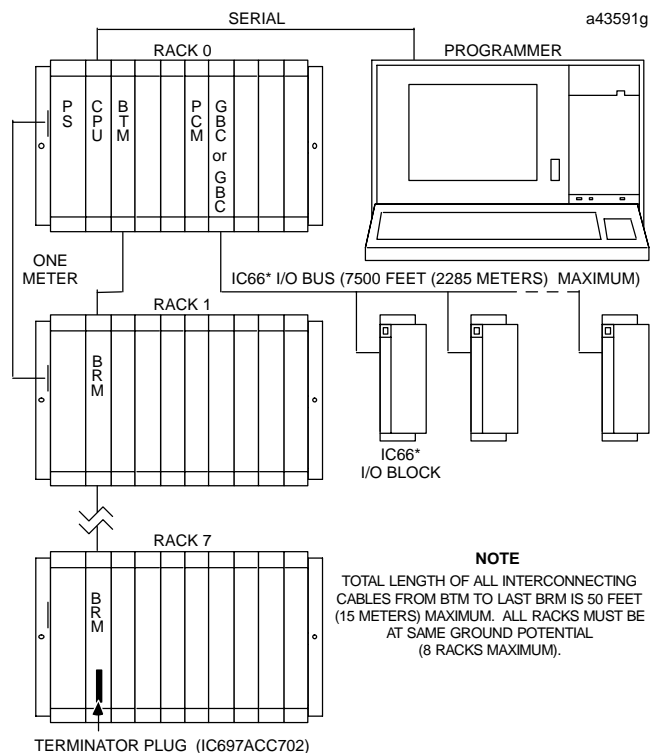

Figure 3. System Configuration, Serial Connection to Programmer

GFK-0767D
August 1997

16 MHz, 32-Bit, Expandable, Floating Point Central Processing Unit

Programmer Connection, Ethernet TCP/IP

Connecting your programmer via an Ethernet TCP/IP network requires installation of an Ethernet Interface module in the PLC. This can be either the Ethernet Controller, IC697CMM741, or Ethernet Interface (Type 2), IC697CMM742. Before connecting your programmer and PLC to the Ethernet TCP/IP network you must set the IP address in the Ethernet Interface. After setting the IP address, connect the PLC and the programmer running Windows software to the Ethernet Interface. For more detailed information on Ethernet TCP/IP, refer to the *TCP/IP Ethernet Communications (Type 2) User's Manual*, and the Windows programming manual, GFK-1295.

Configuration

The IC697 CPU and I/O system is configured with MS-DOS or Windows based programming software. There are no DIP switches or jumpers used to configure the system. The CPU verifies the actual module and rack configuration at power-up and periodically during operation. The actual configuration must be the same as the programmed configuration. Deviations are reported to the CPU alarm processor function for configured fault response. Consult Reference 1 for a description of configuration functions.

Batteries

A lithium battery (IC697ACC701) is installed as shown in Figure 2. This battery maintains program and data memory when power is removed and operates the calendar clock. Be sure to install the new battery before removing the old battery. If during power-up diagnostics a low battery is detected the Module OK LED (top) will not stay on. Specific indication of a low battery state is detailed in Reference 2.

Removing a Module

The following instructions should be followed when removing a module from its slot in a rack.

- Grasp the board firmly at the top and bottom of the board cover with your thumbs on the front of the cover and your fingers on the plastic clips on the back of the cover.
- Squeeze the rack clips on the back of the cover with your fingers to disengage the clip from the rack rail and pull the board firmly to remove it from the backplane connector.
- Slide the board along the card guide and remove it from the rack.

Table 1. Specifications for IC697CPU782 †

Batter	
Shelf Life	10 years at 20° C (68° F)
Memory Retention	6 months nominal without applied power
Current required from 5V Bus	1.6 Amps (includes expansion memory)
Time of Day Clock (internal timing) Accuracy	±3.5 seconds per day
Elapsed Time Clock	±.01% maximum
Serial Port	RS422/485 compatible, Programmer Serial Attachment
VME	System designed to support the VME standard C.1

† Refer to GFK-0867B, or later for product standards and general specifications.

Table 2. References

Reference	Title
1	Programming Software User's Manual
2	Programmable Controller Reference Manual
3	Programmable Controller Installation Manual

16 MHz, 32-Bit, Expandable, Floating Point Central Processing UnitGFK-0767D
August 1997**Table 3. Ordering Information**

Description	Catalog Number
CPU 782, 16 MHz, 32-Bit, Expandable, Floating Point	IC697CPU782
128 Kbyte, 32-Bit CMOS Expansion Memory	IC697MEM731
256 Kbyte with 256 KByte Non-Volatile Flash Memory, 32-bit CMOS Expansion Memory	IC697MEM732
256 Kbyte, 32-Bit CMOS Expansion Memory	IC697MEM733
512 Kbyte, 32-Bit CMOS Expansion Memory	IC697MEM735
Lithium Battery	IC697ACC701

Note: For Conformal Coat option, or Low Temperature Testing option please consult the factory for price and availability.

GFK-1119B
August 1997

32 MHz 32-Bit Floating Point Central Processing Unit, 1 Mbyte Memory

Features

- Single slot CPU
- Provides 1 Mbyte of battery-backed memory in the same slot
- Supports floating point calculations
- 12K inputs and outputs (any mix)
- Up to 8K analog I/O
- 0.4 microseconds per boolean function
- 32 MHz, 80486DX microprocessor
- Supports IC660/IC661 and IC697I/O)
- Programmed by MS-DOS® or Windows® software products running on Windows® 95 or Windows NT® over Ethernet TCP/IP or through the SNP port.
- Configurable data and program memory
- Battery-backed calendar clock
- Three position operation mode switch
- Password controlled access
- Remote programmer keyswitch memory protection
- Four status LEDs
- Software configuration (No DIP switches or jumpers)
- Reference information inside front door
- In-system upgradable firmware

Functions

The CPM 915 Central Processing Unit (CPU) is a single slot programmable controller CPU which allows floating point calculations. The CPM915 is programmed and configured by MS-DOS or Windows based programming software to perform real time control of machines, processes and material handling systems. It communicates with I/O and smart option modules over the rack mounted backplane (IC697CHS750, 782, 783, 790, 791) by way of the VME C.1 Standard format.

Supported option modules include all IC697 LAN interface modules, several Coprocessor modules, Bus Controller for IC660/IC661 I/O, Communications mod-

ules, and all of the IC697 family of discrete and analog I/O modules.

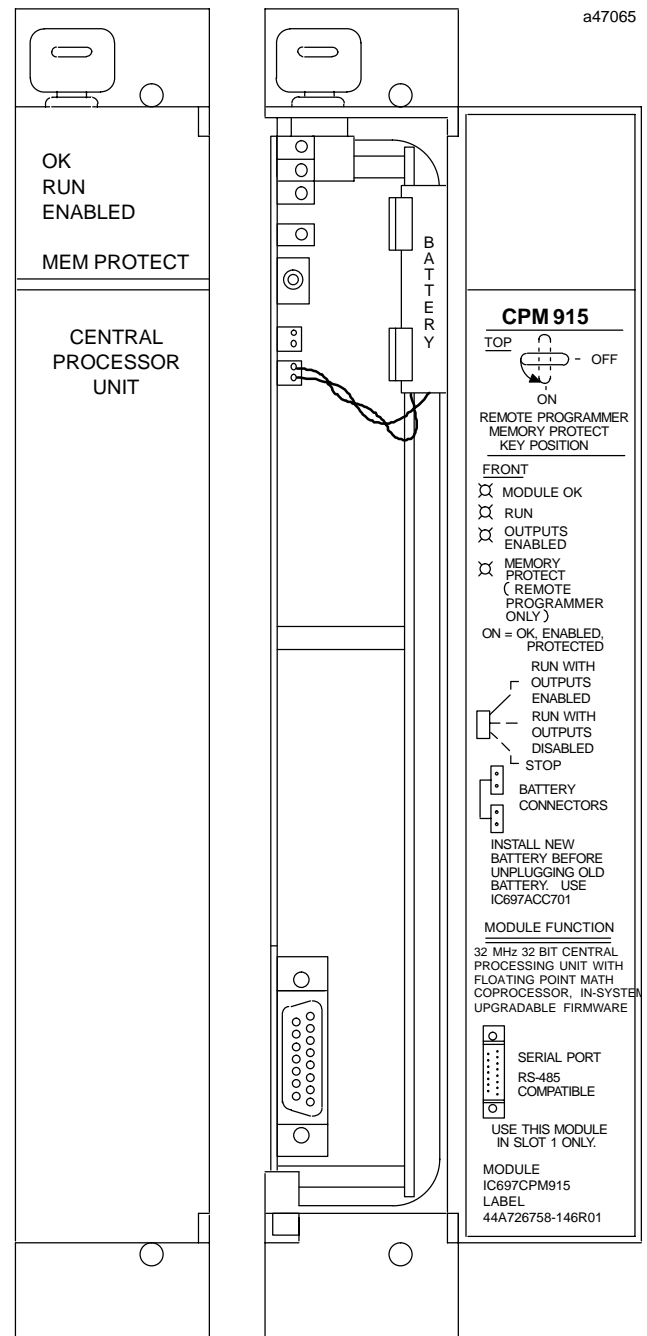

® MS-DOS, Windows, Windows 95, and Windows NT are registered trademarks of Microsoft Corporation.

GFK-1119B
August 1997

32 MHz 32-Bit Floating Point Central Processing Unit, 1 Mbyte Memory

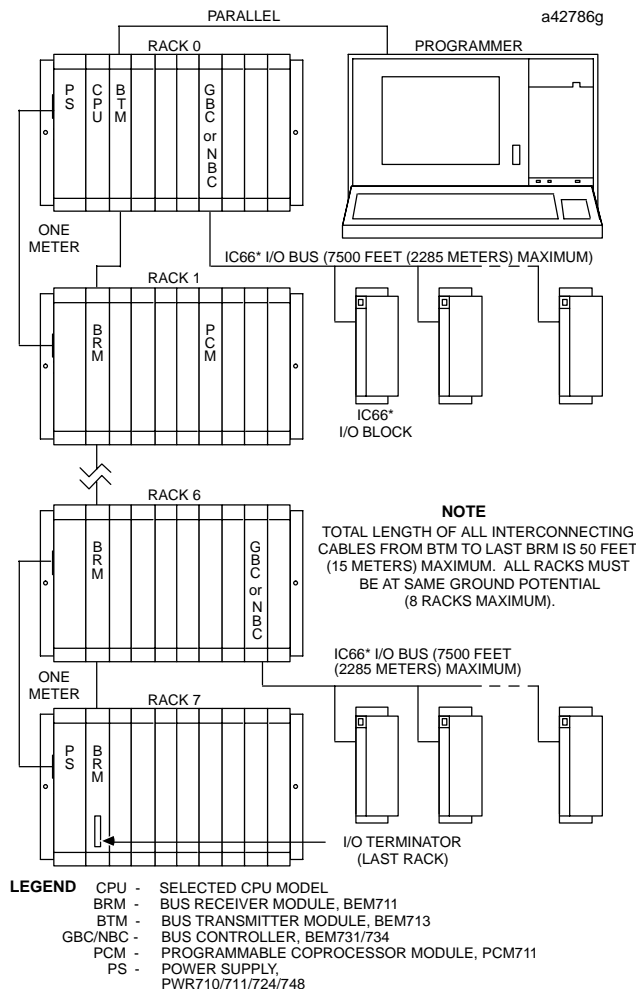

Figure 1. Typical Programmable Controller System Configuration

User Memory

Program and data memory for the CPM 915 is provided by a memory board with 1M byte of battery-backed CMOS RAM. This memory board is an integral part of the CPM 915 module and does not need to be ordered separately.

Flash Memory

This module uses flash memory for storage of the operating system firmware (*Note that this module does not support storage of user program in the flash memory*). This allows updates of the firmware without disassembling the module or replacing EPROMs. The operating system firmware is updated by connecting a PC

compatible computer to the serial port of the module and running the Loader software included with the firmware floppy disk.

Operation, Protection, and Module Status

Operation of this module can be controlled by the three-position RUN/STOP switch or remotely by an attached programmer and programming software. Program and configuration data can be locked through software passwords or manually by the memory protect keyswitch. When the key is in the *protected* position, program and configuration data can only be changed by a programmer connected parallel only (to the Bus Transmitter module). The status of a CPU is indicated by the four green LEDs on the front of the module.

Installation

It is the responsibility of the OEM, system integrator, or end user to properly install the PLC equipment for safe and reliable operation. Product manuals provide detailed information about installation, startup, and proper use of the PLC equipment. The installation manual, shipped with your PLC programming software, describes how to properly install the equipment. If the PLC installation must comply with supported standards, such as FCC or CE Directives, please refer to the *Installation Requirements for Conformance to Standards*, shipped with the PLC programming software, for additional guidelines.

- Installation should not be attempted without referring to the applicable programmable controller hardware installation manual.
- Connect the battery to either of the battery connectors on the module (see Figure 2).
- Put the toggle switch in the STOP position.
- Put the keyswitch in *Memory Protection OFF* position.
- Make sure that rack power is off.
- Install the CPM 915 module in slot 1 of rack 0 (see Figure 1).
- Turn on power.

The module should power up and the top LED should blink. When the diagnostics have completed successfully, the top LED stays on and the second and third LEDs are off. The fourth LED is off if the keyswitch is in the OFF position. The CPU is now ready to be programmed (if connected parallel, the CPU can be programmed regardless of key position).

32 MHz 32-Bit Floating Point Central Processing Unit, 1 Mbyte Memory

GFK-1119B
August 1997

After the program has been verified the toggle switch may be moved to the appropriate operation mode position. The LEDs indicate the position of the toggle switch, memory protection status, and the state of the program.

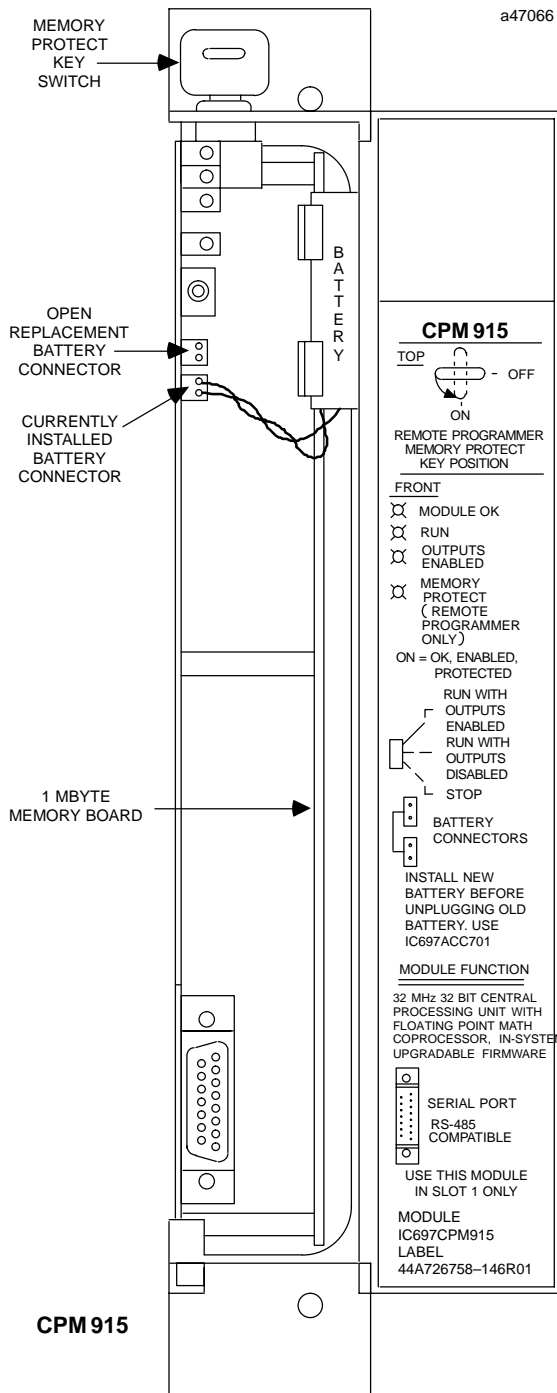

Figure 2. CPM 915 - Location of Major Features

Programmer Connection, Parallel

For a parallel interface (MS-DOS based programmer only) the programmer is connected to the top port on the Bus Transmitter Module (IC697BEM713) as shown in Figure 1. Consult Reference 1 for a description of programming functions.

Serial Port

The 15-pin D-connector provides the connection to an RS-485 compatible serial port on the CPU as shown in Figure 3. This port provides a serial connection to a Work Station Interface board installed in the programming computer.

The serial connection can also be made from the serial port on the CPU to the serial port on the programming computer, or other serial device, through the RS-422/RS-485 to RS-232 Converter (IC690ACC900) or RS-232 to RS-422 Miniconverter (IC690ACC901). This connection can be made with available cables or you may build cables to fit the needs of your particular application. See reference 3 for more information on serial communications.

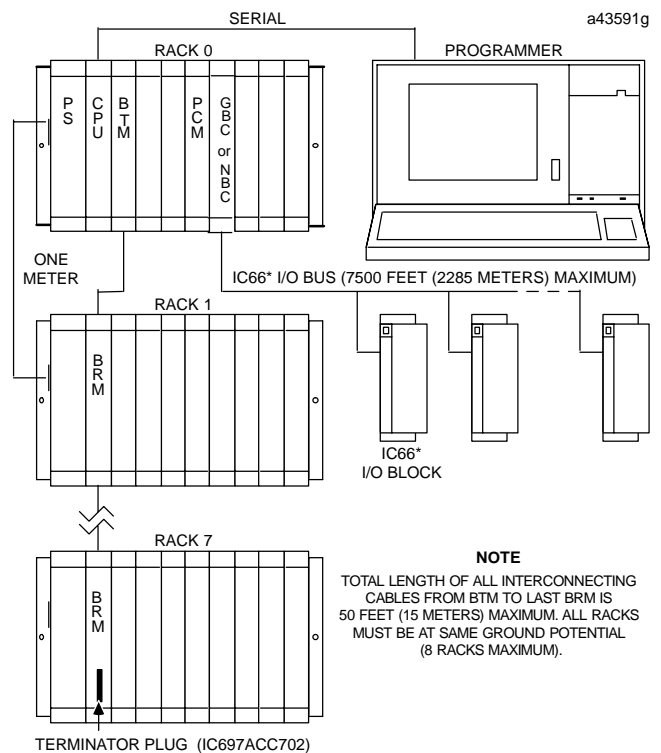

Figure 3. System Configuration, Serial Connection to Programmer

GFK-1119B
August 1997

32 MHz 32-Bit Floating Point Central Processing Unit, 1 Mbyte Memory

Programmer Connection, Ethernet TCP/IP

Connecting your programmer via an Ethernet TCP/IP network requires installation of an Ethernet Interface module in the PLC. This can be either the Ethernet Controller, IC697CMM741, or Ethernet Interface (Type 2), IC697CMM742. Before connecting your programmer and PLC to the Ethernet TCP/IP network you must set the IP address in the Ethernet Interface. After setting the IP address, connect the PLC and the programmer running Windows software to the Ethernet Interface. For more detailed information on Ethernet TCP/IP, refer to the *TCP/IP Ethernet Communications (Type 2) User's Manual*, and the Windows programming manual, GFK-1295.

Configuration

The IC697 CPU and I/O system is configured with MS-DOS or Windows based programming software. There are no DIP switches or jumpers used to configure the system. The CPU verifies the actual module and rack configuration at power-up and periodically during operation. The actual configuration must be the same as the programmed configuration. Deviations are reported to the CPU alarm processor function for configured fault response. Consult Reference 1 for a description of configuration functions.

Batteries

A lithium battery (IC697ACC701) is installed as shown in Figure 2. This battery maintains program and data memory when power is removed and operates the calendar clock. Be sure to install the new battery before removing the old battery. Specific indication of a low battery state is detailed in Reference 2.

Removing a Module

The instructions below should be followed when removing a module from its slot in a rack.

- Grasp the board firmly at the top and bottom of the board cover with your thumbs on the front of the cover and your fingers on the plastic clips on the back of the cover.
- Squeeze the rack clips on the back of the cover with your fingers to disengage the clip from the rack rail and pull the board firmly to remove it from the backplane connector.
- Slide the board along the card guide and remove it from the rack.

Table 1. References

Reference	Title
1	Programming Software User's Manual
2	Programmable Controller Reference Manual
3	Programmable Controller Installation Manual

32 MHz 32-Bit Floating Point Central Processing Unit, 1 Mbyte MemoryGFK-1119B
August 1997

Table 2. Specifications for IC697CPM915 †

Battery	
Shelf life	10 years at 20° C (68° F)
Memory retention	6 months nominal without applied power.
Current required from 5V bus	2.8 Amps nominal
Time of Day Clock accuracy	" 3.5 seconds per day maximum
Elapsed Time Clock (internal timing) accuracy	" .01% maximum
Serial Port	
RS422/485 compatible	Programmer Serial Attachment
VME	System designed to support the VME standard C.1

† Refer to GFK-0867B, or later for product standards and general specifications.

Table 3. Ordering Information

Description	Catalog Number
Central Processing Unit 32 MHz, 32-Bit, Floating Point, 1 Mbyte Memory	IC697CPM915
Lithium Battery	IC697ACC701

Note: For Conformal Coat option, or Low Temperature Testing option please consult the factory for price and availability.

GFK-1120D
November 1999

64 MHz, 32-Bit Floating Point Central Processing Unit, 1 Mbyte Memory

Features

- Single slot CPU
- Provides 1 Mbyte of battery-backed memory in the same slot
- Supports floating point calculations
- 12K inputs and outputs (any mix)
- Up to 8K analog I/O
- 0.4 microseconds per boolean function
- 64 MHz, 80486DX2 microprocessor
- Supports IC660/IC661 and IC697I/O
- Programmed by MS-DOS® or Windows® software products running on Windows® 95 or Windows NT® over Ethernet TCP/IP or through the SNP port
- Configurable data and program memory
- Battery-backed calendar clock
- Three position operation mode switch
- Password controlled access
- Remote programmer keyswitch memory protection
- Four status LEDs
- Software configuration (No DIP switches or jumpers)
- Reference information inside front door
- In-system upgradable firmware

Functions

The CPM 925 is a single slot programmable controller CPU which allows floating point calculations. The CPM 925 CPU is programmed and configured by MS-DOS or Windows based programming software to perform real time control of machines, processes and material handling systems. It communicates with I/O and smart option modules over the rack mounted backplane (IC697CHS750, 782, 783, 790, 791) by way of the VME C.1 Standard format.

Supported option modules include all IC697 LAN interface modules, several Coprocessor modules, Bus Controller for IC660/IC661 I/O, Communications modules, and all of the IC697 family of discrete and analog I/O modules.

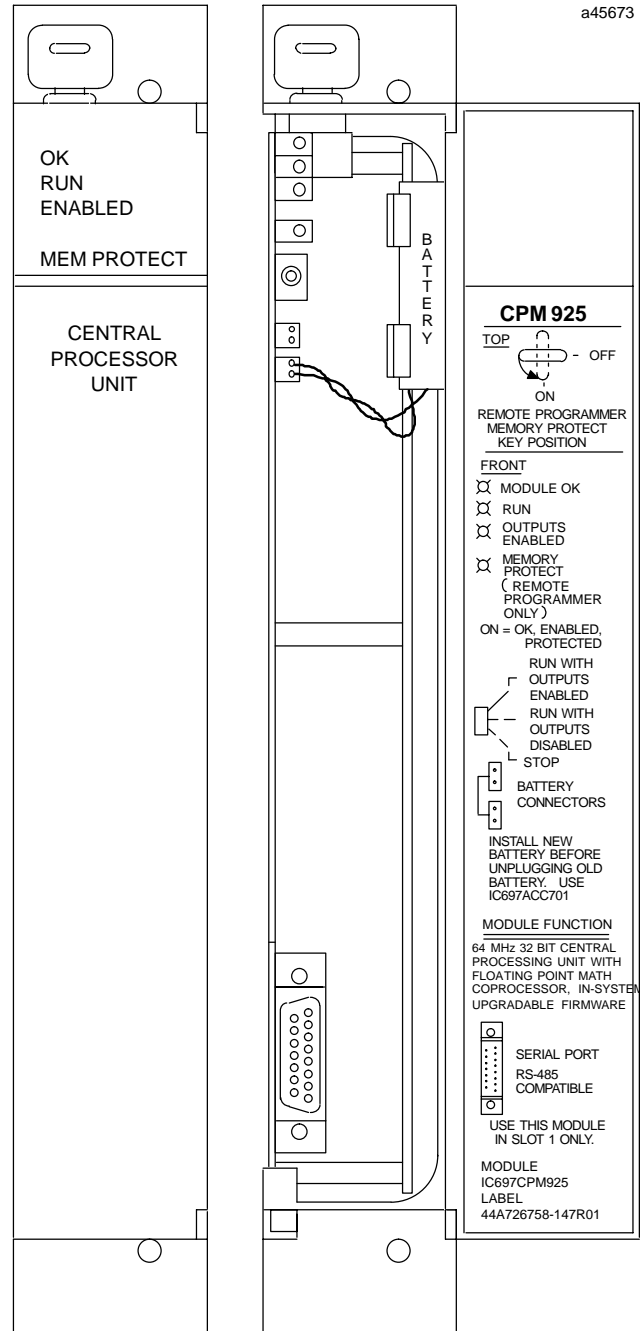

© MS-DOS, Windows, Windows 95, and Windows NT are registered trademarks of Microsoft Corporation.

GFK-1120D
November 1999

64 MHz, 32-Bit Floating Point Central Processing Unit, 1 Mbyte Memory

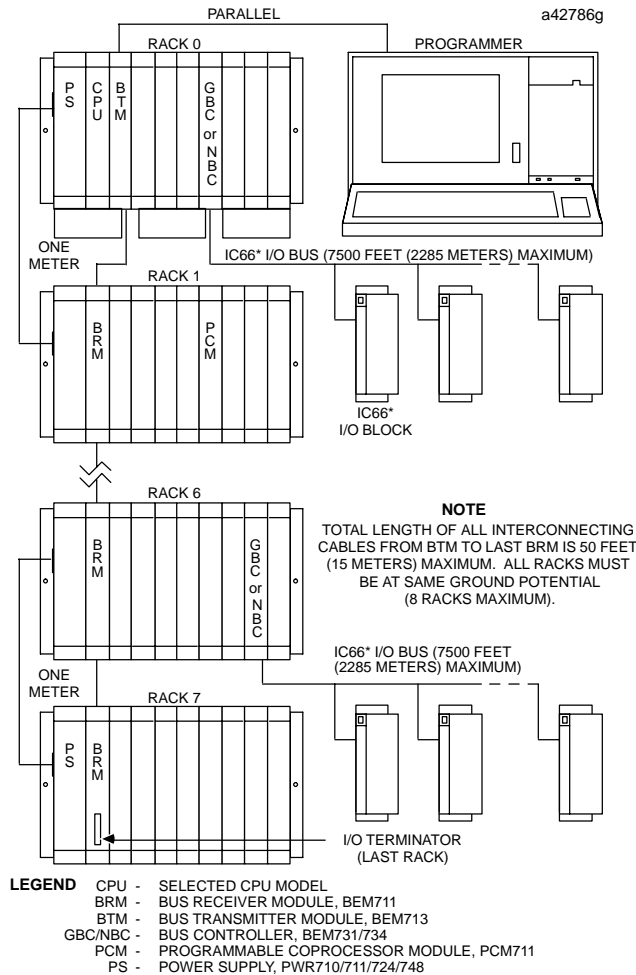

Figure 1. Typical Programmable Controller System Configuration

User Memory

Program and data memory for the CPM 925 is provided by a memory board with 1 Mbyte of battery-backed CMOS RAM. This memory board is an integral part of the CPM 925 module and is included with the module..

Flash Memory

This module uses flash memory for storage of the operating system firmware (*this module does not support storage of user program in the flash memory*). This allows updates of the firmware without disassembling the module or replacing EPROMs. The operating system firmware is updated by connecting a PC compatible computer to the module's serial port and running the Loader software included with the firmware floppy disk.

Operation, Protection, and Module Status

Operation of this module can be controlled by the three-position RUN/STOP switch or remotely by an attached programmer and programming software. Program and configuration data can be locked through software passwords or manually by the memory protect keyswitch. When the key is in the *protected* position, program and configuration data can only be changed by a programmer connected parallel only (to the Bus Transmitter module). The status of a CPU is indicated by the four green LEDs on the front of the module.

The CPM 925 requires forced air cooling for proper operation in ambient temperatures greater than 40°C (104°F). A fan capable of 70 CFM (including filters) should be located beneath slot 1 of the rack containing the CPU.

Fan assemblies (IC697ACC721, IC697ACC724, and IC697ACC744) can be ordered for direct mounting on the IC697 rack. Refer to the applicable *Programmable Controller Installation Manual* for detailed information.

Installation

It is the responsibility of the OEM, system integrator, or end user to properly install the PLC equipment for safe and reliable operation. Product manuals provide detailed information about installation, startup, and proper use of the PLC equipment. The installation manual, shipped with your PLC programming software, describes how to properly install the equipment. If the PLC installation must comply with supported standards, such as FCC or CE Directives, please refer to the *Installation Requirements for Conformance to Standards*, shipped with the PLC programming software, for additional guidelines.

- Installation should not be attempted without referring to the applicable *Programmable Controller Installation Manual*.
- Connect the battery to either of the battery connectors on the module (see Figure 2).
- Put the toggle switch in the STOP position.
- Put the keyswitch in the *Memory Protection OFF* position.
- Make sure that rack power is off.
- Install the CPM 925 module in slot 1 of rack 0 (see Figure 1).
- Turn on power.

64 MHz, 32-Bit Floating Point Central Processing Unit, 1 Mbyte Memory

GFK-1120D
November 1999

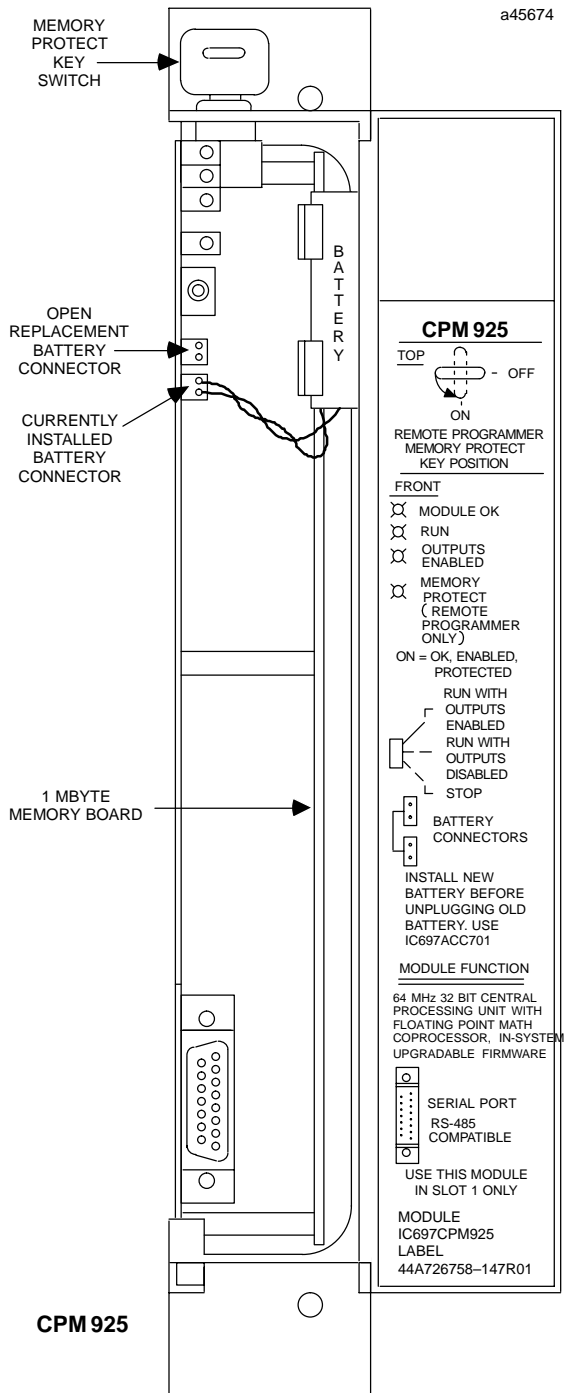

Figure 2. CPM 925 - Location of Major Features

The module should power up and the top LED should blink. When the diagnostics have completed successfully, the top LED stays on and the second and

third LEDs are off. The fourth LED is off if the keyswitch is in the OFF position. The CPU is now ready to be programmed (if connected parallel, the CPU can be programmed regardless of key position). After the program has been verified the toggle switch can be moved to the appropriate operation mode position. The LEDs indicate the position of the toggle switch, memory protection status, and the state of the program.

Programmer Connection, Parallel

For a parallel interface (MS-DOS programmer only) the programmer is connected to the top port on the Bus Transmitter Module (IC697BEM713) as shown in Figure 1. See Reference 1 for a description of programming functions.

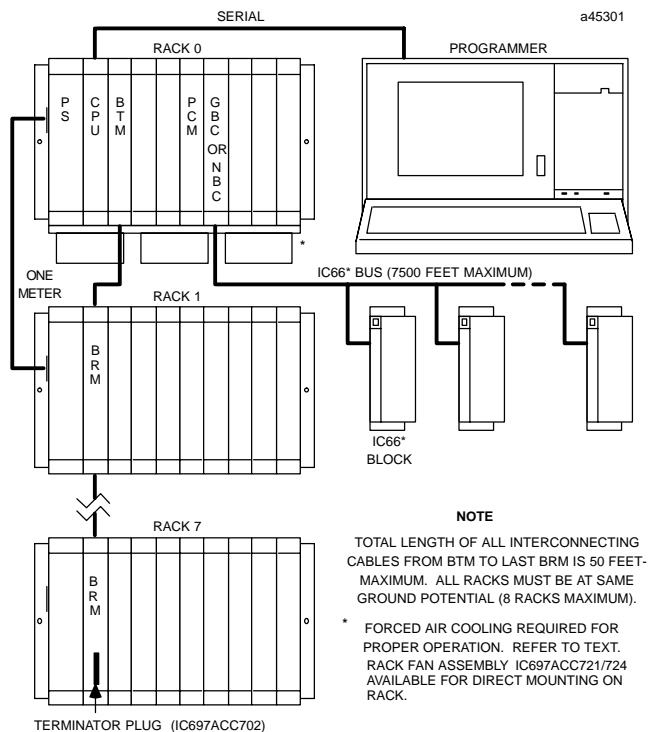

Figure 3. System Configuration, Serial Connection to Programmer

Serial Port

The 15-pin D-conductor provides the connection to an RS-485 compatible serial port on the CPU (see Figure 3). This port provides a serial connection to a Work Station Interface board installed in the programming computer.

The serial connection can also be made from the serial port on the CPU to the serial port on the programming

GFK-1120D
November 1999

64 MHz, 32-Bit Floating Point Central Processing Unit, 1 Mbyte Memory

computer, or other serial device, through the RS-422/RS-485 to RS-232 Converter (IC690ACC900) or RS-232 to RS-422 Miniconverter (IC690ACC901). This connection can be made with available cables or you may build cables to fit the needs of your particular application. See reference 3 for more information on serial communications.

Programmer Connection, Ethernet TCP/IP

Connecting your programmer via an Ethernet TCP/IP network requires installation of an Ethernet Interface module in the PLC. This can be either the Ethernet Controller, IC697CMM741, or Ethernet Interface (Type 2), IC697CMM742. Before connecting your programmer and PLC to the Ethernet TCP/IP network you must set the IP address in the Ethernet Interface. After setting the IP address, connect the PLC and the programmer running Windows software to the Ethernet Interface.

For more detailed information on Ethernet TCP/IP, refer to the *TCP/IP Ethernet Communications (Type 2) User's Manual*, and the Windows programming manual, GFK-1295.

Configuration

The IC697 CPU and I/O system is configured with MS-DOS or Windows based programming software. There are no DIP switches or jumpers used to configure the system. The CPU verifies the actual module and rack configuration at power-up and periodically during operation. The actual configuration must be the same as the programmed configuration. Deviations are reported to the CPU alarm processor function for configured fault response. Consult Reference 1 for a description of configuration functions.

Batteries

A lithium battery (IC697ACC701) is installed as shown in Figure 2. This battery maintains program and data memory when power is removed and operates the calendar clock. Be sure to install the new battery before removing the old battery. Specific indication of a low battery state is detailed in Reference 2.

Removing a Module

The instructions below should be followed when removing a module from its slot in a rack.

- Grasp the board firmly at the top and bottom of the board cover with your thumbs on the front of the cover and your fingers on the plastic clips on the back of the cover.
- Squeeze the rack clips on the back of the cover with your fingers to disengage the clip from the rack rail and pull the board firmly to remove it from the backplane connector.
- Slide the board along the card guide and remove it from the rack.

Table 1. References

Reference	Title
1	Programming Software User's Manual
2	Programmable Controller Reference Manual
3	Programmable Controller Installation Manual

64 MHz, 32-Bit Floating Point Central Processing Unit, 1 Mbyte MemoryGFK-1120D
November 1999**Table 2. Specifications for IC697CPM925 †**

Battery	
Shelf life	10 years at 20° C (68° F)
Memory retention	6 months nominal without applied power.
Current required from 5V bus	3.3 Amps nominal
Operating Temperature	0 to 60° C (32° F to 140° F); <i>70 CFM forced air required</i> 0 to 40° C (32° F to 104° F); <i>without forced air</i>
Time of Day Clock accuracy	" 3.5 seconds per day maximum
Elapsed Time Clock (internal timing) accuracy	" .01% maximum
Serial Port	
RS422/485 compatible	Programmer Serial Attachment
VME	System designed to support the VME standard C.1

† Refer to GFK-0867B, or later for product standards and general specifications.

Table 3. Ordering Information

Description	Catalog Number
Central Processing Unit 64 MHz, 32-Bit, Floating Point, 1 Mbyte Memory	IC697CPM925
Lithium Battery	IC697ACC701
Rack Fan Assembly, 120 VAC	IC697ACC721
Rack Fan Assembly, 240 VAC	IC697ACC724
Rack Fan Assembly, 24 VDC	IC697ACC744

Note: For Conformal Coat option, or Low Temperature Testing option please consult the factory for price and availability.

PLC CPUs

IC697CPX772

GFK-1429F
November 1999

**96 MHz, 32-Bit Point, 512 Kbyte (Slow) Memory
Central Processing Unit**

Features

- Single slot CPU with three serial ports
- Provides 512 Kbyte of battery-backed RAM memory in the same slot
- Contains 256K of non-volatile user flash memory
- Supports BMA in release 7.92 and later
- Supports floating point calculations
- 2K inputs and outputs (any mix), and up to 8K analog I/O
- 0.4 microseconds per boolean function
- 96 MHz, 80486DX4 microprocessor
- Supports IC66 (can be IC660 or IC661) and IC697 I/O
- Programmed by MS-DOS® software products, or Windows® based software products running on Windows® 95 or Windows NT® over Ethernet TCP/IP, or through an SNP port
- Configurable data and program memory
- Battery-backed calendar clock
- Three position operation mode switch
- Password controlled access
- Remote programmer keyswitch memory protection
- Seven status LEDs
- Software configuration (No DIP switches or jumpers)
- Reference information inside front door
- In-system upgradable firmware

Functions

The CPX772 is a single slot PLC CPU that is programmed and configured by MS-DOS or Windows based programming software to perform real time control of machines, processes and material handling systems. It communicates with I/O and smart option modules over the rack-mounted backplane using the VME C.1 Standard format.

Supported option modules include LAN Interface modules, Programmable Coprocessor, Alphanumeric Display Coprocessor, Bus Controller for IC660/661 I/O products, Communications modules, I/O Link Interface, and all of the IC697 family of discrete and analog I/O modules.

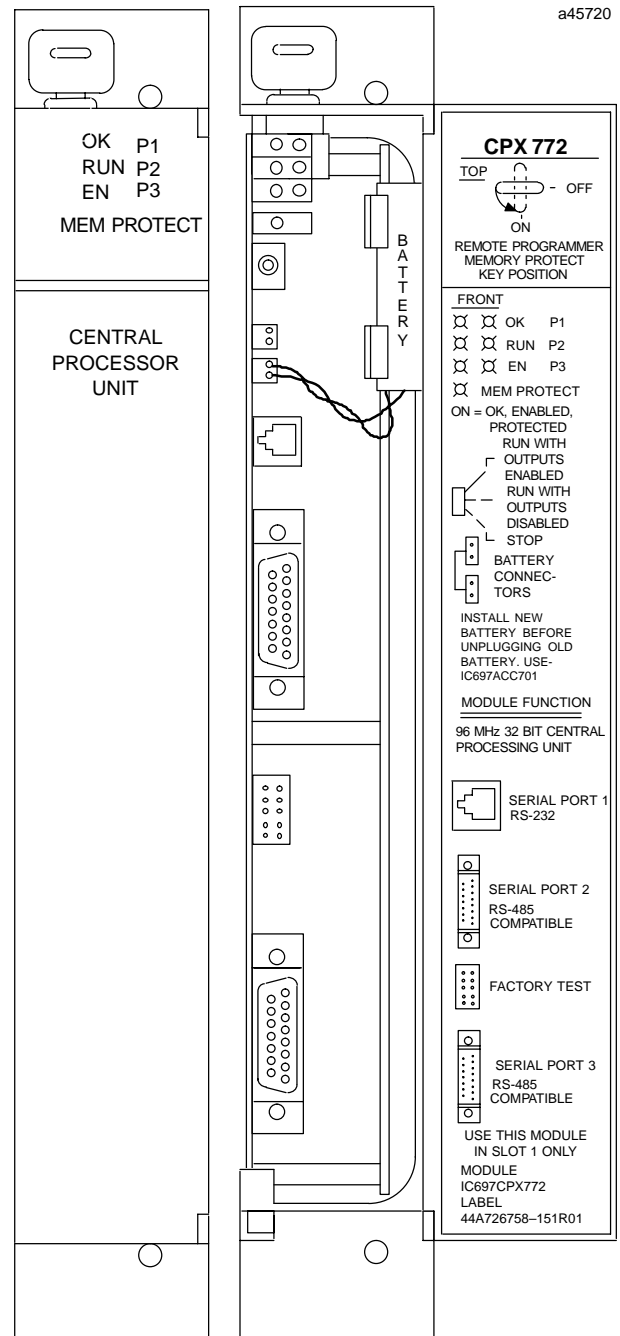

© MS-DOS, Windows, Windows 95, and Windows NT are registered trademarks of Microsoft Corporation.

GFK-1429F
November 1999

**96 MHz, 32-Bit Point, 512 Kbyte (Slow) Memory
Central Processing Unit**

updated by connecting a PC compatible computer to the module's serial port and running the software included with the firmware upgrade kit.

Operation, Protection, and Module Status

Operation of this module can be controlled by the three-position RUN/STOP switch or remotely by an attached programmer and programming software. Program and configuration data can be locked through software passwords or manually by the memory protect keyswitch. When the key is in the *protected* position, program and configuration data can only be changed by a programmer connected parallel only (to the Bus Transmitter module). CPU status is indicated by the seven green LEDs on the front of the module.

Operating Temperature

For continuous operation above 50 degrees C, such as in a minimum size enclosure with no air flow, derating is necessary for the 100W AC/DC Power Supply (PWR711), and the 90W DC Power Supplies (PWR724/PWR748), as shown in the chart below.

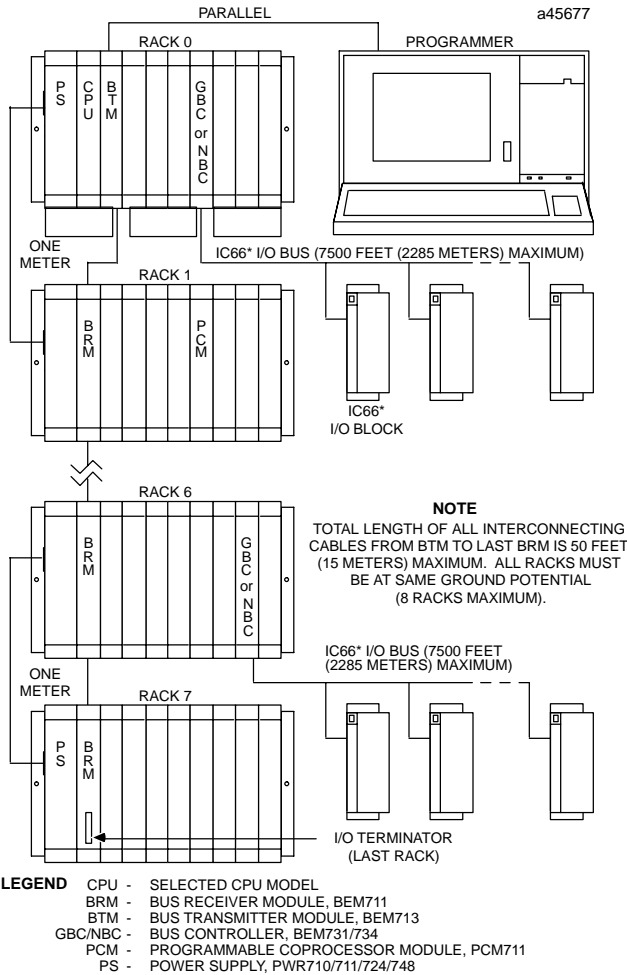
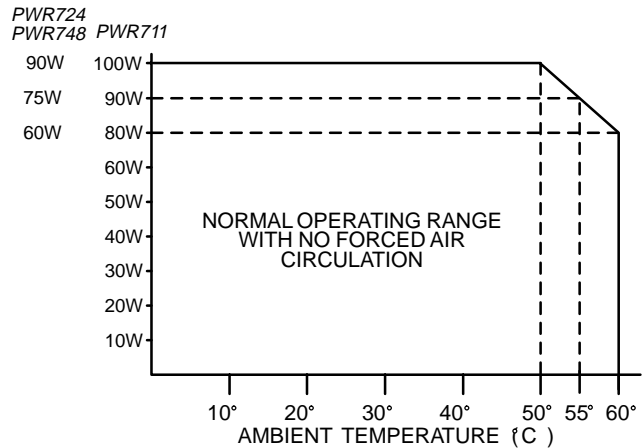

Figure 1. PLC System Configuration Example

User RAM Memory

The CPX772 has a built-in memory board with 512K of battery-backed CMOS RAM memory for user data (program, configuration, and register data) storage.

User Flash Memory

The CPX772 has 256K of built-in, non-volatile flash memory for user data (program, configuration, register data) storage. Use of this flash memory is optional.

Firmware Storage in Flash Memory

This CPU uses non-volatile flash memory for storing the operating system firmware. This allows firmware to be updated without disassembling the module or replacing EPROMs. The operating system firmware is

Installation

It is the responsibility of the OEM, system integrator, or end user to properly install the PLC equipment for safe and reliable operation. Product manuals provide detailed information about installation, startup, and proper use of the PLC equipment. The installation manual, shipped with your PLC programming software, describes how to properly install the equipment.

96 MHz, 32-Bit Point, 512 Kbyte (Slow) Memory Central Processing Unit

GFK-1429F
November 1999

If the PLC installation must comply with supported standards, such as FCC or CE Directives, please refer to the *Installation Requirements for Conformance to Standards*, shipped with the PLC programming software, for additional guidelines.

Installation should not be attempted without referring to the applicable *Programmable Controller Installation Manual*.

- Connect the battery to either of the battery connectors on the module (see Figure 2).
- Put the toggle switch in the STOP position.
- Put the keyswitch in the *Memory Protection OFF* position.
- Make sure that rack power is off.
- Install the CPX 772 module in slot 1 of rack 0 (see Figure 1).
- Turn on power.

The module should power up and the top left (OK) LED should blink. When the diagnostics have completed successfully, the top left LED stays on and the second (RUN) and third (EN) LEDs are off. The fourth (bottom left) LED (MEM PROTECT) is off if the keyswitch is in the OFF position. The CPU is now ready to be programmed (if connected parallel, the CPU can be programmed regardless of key position).

After the program has been verified the toggle switch can be moved to the appropriate operation mode position; RUN WITH OUTPUTS ENABLED, RUN WITH OUTPUTS DISABLED, or STOP. The seven LEDs indicate the position of the toggle switch, memory protection status, status of serial port activity, and the state of the program.

Programmer Connection, Parallel

For a parallel interface (MS-DOS programmer only) the programmer is connected to the top port on the Bus Transmitter Module (IC697BEM713) as shown in Figure 1. Consult the applicable *Programming Software User's Manual* for a description of programming functions.

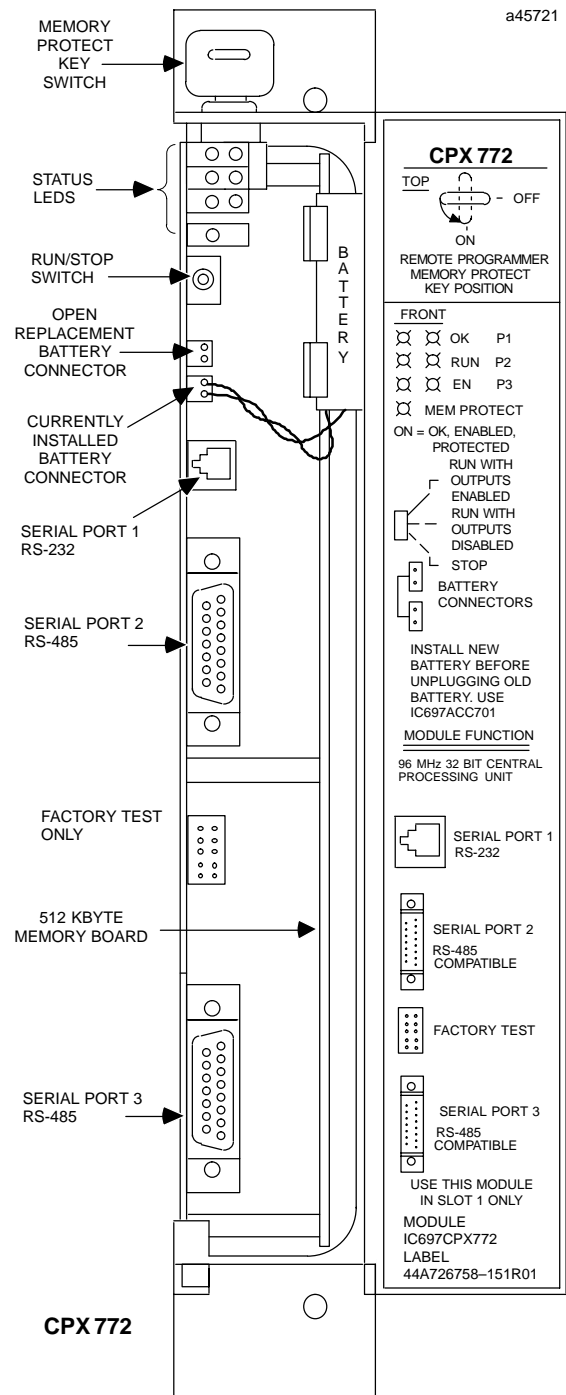

Figure 2. CPX 772 - Location of Major Features

GFK-1429F
November 1999

**96 MHz, 32-Bit Point, 512 Kbyte (Slow) Memory
Central Processing Unit**

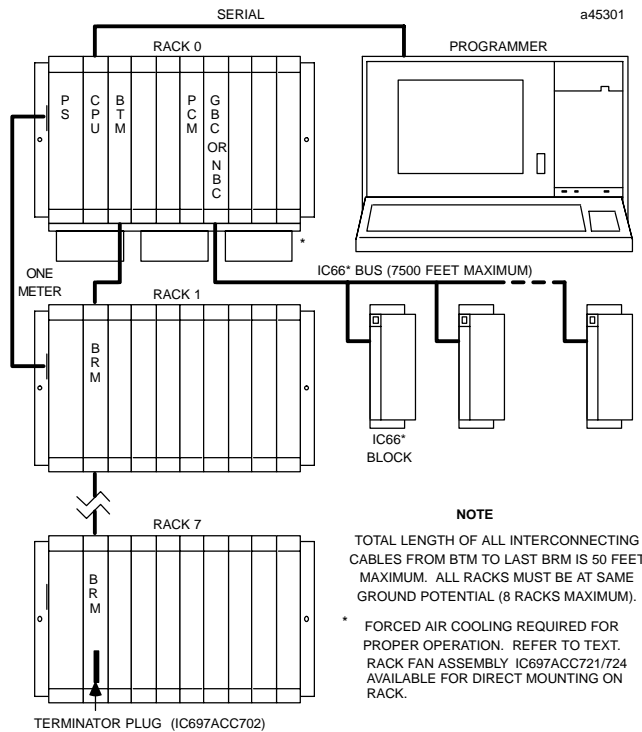

Figure 3. System Configuration, Serial Connection to Programmer

Programmer Connection, Serial Ports

The CPX 772 has three independent, on-board serial ports. These ports, accessed by connectors on the front of the module, are used for serial interface to a programming computer or other serial devices.

Starting with Firmware Release 8.00, support for program Load/Store operations and Datagrams was added to Ports 1 and 2. Also, Break-Free SNP was added as the default protocol for Ports 1 and 2 in Firmware Release 8.00. For details, see the *Important Product Information* sheet that ships with the module.

Protocols Supported

Protocol	Port 1	Port 2	Port 3
SNP (Slave)	Yes	Yes	Yes
Break-Free SNP (Slave)	Yes	Yes	No
SNPX	No	No	No
RTU	No	No	No

- **Port 1**, the top port, is RS-232 compatible. It has a 6-pin, female, RJ-11 connector, which is similar in appearance (although larger) to modular jacks commonly used for telephones and modems.

Table 1. Port 1 RS-232 Signals

Pin Number	Signal Name	Description
1 *	CTS	Clear To Send
2	TXD	Transmit Data
3	0V	Signal Ground
4	0V	Signal Ground
5	RXD	Receive Data
6	RTS	Request to Send

* Pin 1 is at the top of the connector as viewed from the front of the module.

- **Port 2**, the center port, is RS-485 compatible and is optocoupler isolated. Port 2 has a 15-pin, female D-connector.

Table 2. Port 2 RS-485 Signals

Pin Number	Signal Name	Description
1*	Shield	Cable Shield
2	NC	No Connection
3	NC	No Connection
4	NC	No Connection
5	+5VDC	Logic Power **
6	RTS(A)	Differential Request to Send
7	SG	Signal Ground
8	CTS(B')	Differential Clear To Send
9	RT	Resistor Termination
10	RD(A)	Differential Receive Data
11	RD(B')	Differential Receive Data
12	SD(A)	Differential Send Data
13	SD(B)	Differential Send Data
14	RTS(B')	Differential Request To Send
15	CTS(A)	Differential Clear To Send

*Pin 1 is at the bottom right of the connector as viewed from the front of the module.

** Note that Pin 5 provides Isolated +5 VDC power (100 mA maximum) for powering external options.

- **Port 3**, the bottom port, is also RS-485 compatible, but is not isolated. Port 3 has a 15-pin, female D-connector. Pin-out information can be found in the *IC697 PLC Installation Manual*.

**96 MHz, 32-Bit Point, 512 Kbyte (Slow) Memory
Central Processing Unit**GFK-1429F
November 1999

Three of the LED indicators on the front of the CPX 772 provide the status of serial port activity on the CPU without having a terminal connected. The LEDs are labeled as P1, P2, and P3 to correspond to the applicable port.

The connection from a CPU serial port to the serial port on a programming computer or other serial device requires a serial cable and, for Ports 2 and 3, a converter. This connection can be made with the IC690ACC901 cable kit (includes cable and miniconverter) or you may build cables to fit the needs of your particular application. See the *IC697 PLC Installation Manual* for more information on serial communications, cables, and converters.

Programmer Connection, Ethernet TCP/IP

Connecting your programmer via an Ethernet TCP/IP network requires installation of an Ethernet Interface module in the PLC. This can be either the Ethernet Controller, IC697CMM741, or Ethernet Interface (Type 2), IC697CMM742. Before connecting your programmer and PLC to the Ethernet TCP/IP network you must set the IP address in the Ethernet Interface. After setting the IP address, connect the

PLC and the programmer running Windows software to the Ethernet Interface. For more detailed information on the programmer connection via Ethernet TCP/IP, refer to the *TCP/IP Ethernet Communications (Type 2) User's Manual*, and the Windows programming manual, GFK-1295.

Configuration

The IC697 CPU and I/O system is configured with MS-DOS or Windows based programming software, although the MS-DOS software does not support all features, such as Bulk Memory Area (BMA), which requires the Windows software version 2.2 or later. See the IPI shipped with this module for programming software feature support details. There are no DIP switches or jumpers used to configure the system. The CPU verifies the actual module and rack configuration at power-up and periodically during operation. The actual configuration must be the same as the programmed configuration. Deviations are reported to the CPU alarm processor function for configured fault response. Refer to the applicable *Programming Software User's Manual* for a description of configuration functions.

GFK-1429F
November 1999

96 MHz, 32-Bit Point, 512 Kbyte (Slow) Memory Central Processing Unit

Battery

A lithium battery (IC697ACC701) is installed as shown in Figure 2. This battery maintains program and data memory when power is removed and operates the calendar clock. Be sure to install the new battery before removing the old battery. Specific indication of a low battery state is detailed in the applicable *Programmable Controller Reference Manual*.

- Grasp the board firmly at the top and bottom of the board cover with your thumbs on the front of the cover and your fingers on the plastic clips on the back of the cover.
- Squeeze the rack clips on the back of the cover with your fingers to disengage the clip from the rack rail and pull the board firmly to remove it from the backplane connector.
- Slide the board along the card guide and remove it from the rack.

Removing a Module

The instructions listed below should be followed when removing a module from its slot in a rack.

Table 3. Specifications for IC697CPX772 †

Battery: Shelf life	5 years at 20° C (68° F)
Battery: Memory retention	6 months nominal without applied power.
Current required from 5V bus	3.1 Amps nominal
Operating Temperature	0 to 60°C (32°F to 140°F)
Time of Day Clock accuracy	" 3.5 seconds per day maximum
Elapsed Time Clock (internal timing) accuracy	" .01% maximum
Serial Ports Port 1: RS-232 compatible Port 2: RS-485 compatible (optocoupler isolated) Port 3: RS-485 compatible (not isolated)	Programmer Serial Attachment, or other serial devices Protocols supported: SNP Slave only
VME Compatibility	System designed to support the VME standard C.1

† Refer to GFK-0867B, or later for product standards and general specifications. For installations requiring compliance to more stringent requirements (for example, FCC or European Union Directives), refer to *Installation Requirements for Conformance to Standards*.

Table 4. Ordering Information

Description	Catalog Number
Central Processing Unit 96 MHz, 32-Bit, Floating Point, 512 Kbyte Memory	IC697CPX772
Lithium Battery	IC697ACC701
Rack Fan Assembly, 120 VAC	IC697ACC721
Rack Fan Assembly, 240 VAC	IC697ACC724
Rack Fan Assembly, 24 VDC	IC697ACC744

Note: For Conformal Coat option please consult the factory for price and availability.

PLC CPUs

IC697CPX782

GFK-1431F
November 1999

96 MHz, 32-Bit, Floating Point, 1 Mbyte Memory Central Processing Unit

Features

- Single slot CPU with three serial ports
- Provides 1 Mbyte of battery-backed memory in the same slot
- Contains 256K of non-volatile user flash memory
- Supports BMA in release 7.92 and later
- Supports floating point calculations
- 12K inputs and outputs (any mix), and up to 8K analog I/O
- 0.4 microseconds per boolean function
- 96 MHz, 80486DX4 microprocessor
- Supports IC66 (can be IC660 or IC661) and IC697 I/O
- Programmed by MS-DOS® software products, or Windows® based software products running on Windows® 95 or Windows NT® over Ethernet TCP/IP, or through an SNP port
- Configurable data and program memory
- Battery-backed calendar clock
- Three position operation mode switch
- Password controlled access
- Remote programmer keyswitch memory protection
- Seven status LEDs
- Software configuration (No DIP switches or jumpers)
- Reference information inside front door
- In-system upgradable firmware
- Three Series Ninety Protocol (SNP Slave) ports

Functions

The CPX 782 is a single slot PLC CPU that is programmed and configured by MS-DOS or Windows based programming software to perform real time control of machines, processes, and material handling systems. It communicates with I/O and smart option modules over a rack-mounted backplane using the VME C.1 Standard format.

Supported option modules include LAN Interface modules, Programmable Coprocessor, Alphanumeric Display Coprocessor, Bus Controller for IC660/661 I/O products, Communications modules, I/O Link Interface, and all of the IC697 family of discrete and analog I/O modules.

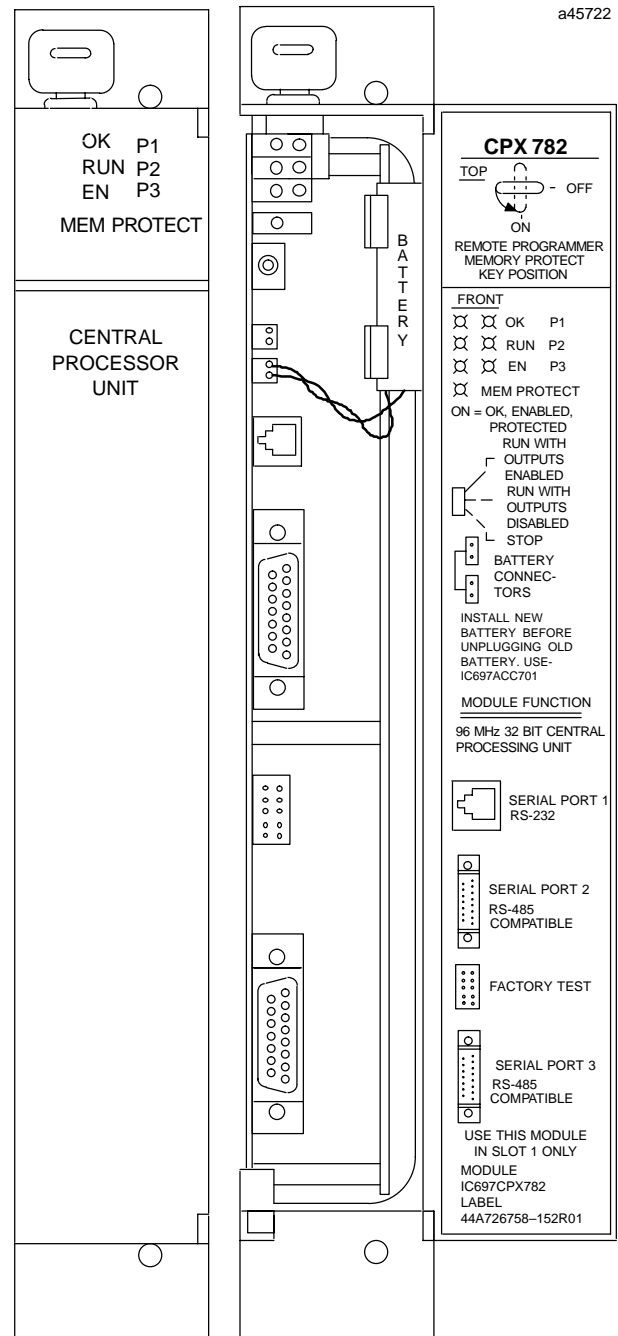

a45722

© MS-DOS, Windows, Windows 95, and Windows NT are registered trademarks of Microsoft Corporation.

GFK-1431F
November 1999

**96 MHz, 32-Bit, Floating Point, 1 Mbyte Memory
Central Processing Unit**

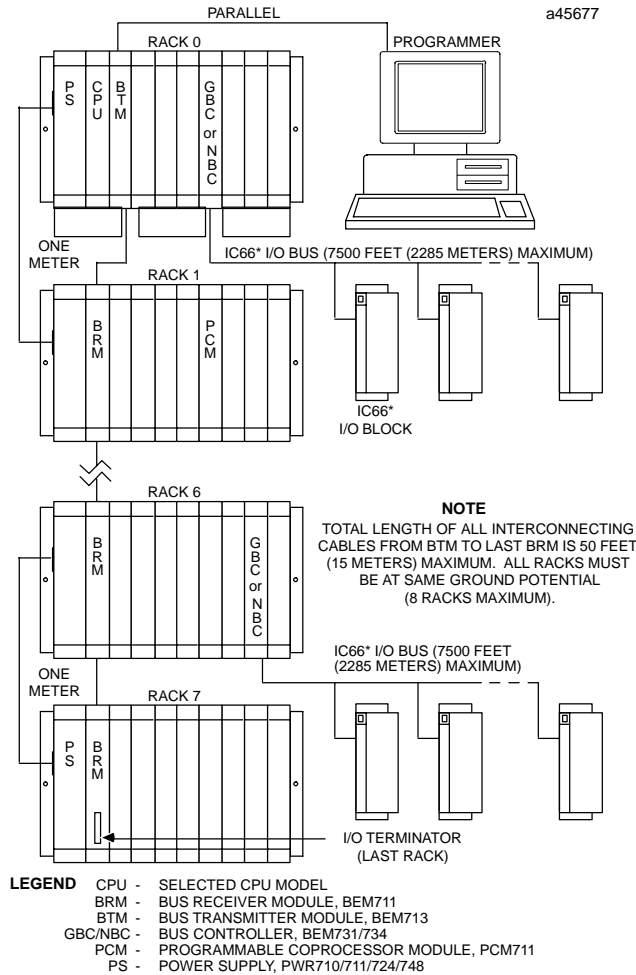

Figure 1. PLC System Configuration Example

User RAM Memory

The CPX782 has a built-in memory board with 1 Mbyte of battery-backed CMOS RAM memory for user data (program, configuration, and register data) storage.

User Flash Memory

The CPX782 has 256K of built-in flash memory for user data (program, configuration, and register data) storage. Use of this flash memory is optional.

Firmware Storage in Flash Memory

This CPU uses non-volatile flash memory for storing the operating system firmware. This allows firmware to be updated without disassembling the module or

replacing EPROMs. The operating system firmware is updated by connecting a PC compatible computer to the module's serial port and running the software included with the firmware upgrade kit.

Operation, Protection, and Module Status

Operation of this module can be controlled by the three-position RUN/STOP switch or remotely by an attached programmer and programming software. Program and configuration data can be locked through software passwords or manually by the memory protect keyswitch. When the key is in the *protected* position, program and configuration data can only be changed by a programmer connected parallel only (to the Bus Transmitter module). The status of a CPU is indicated by the seven green LEDs on the front of the module.

Operating Temperature

For continuous operation in a minimum size enclosure with no air flow, derating is necessary for the 100W AC/DC Power Supply (PWR711), and the 90W DC Power Supplies (PWR724/PWR748) as shown in the chart below.

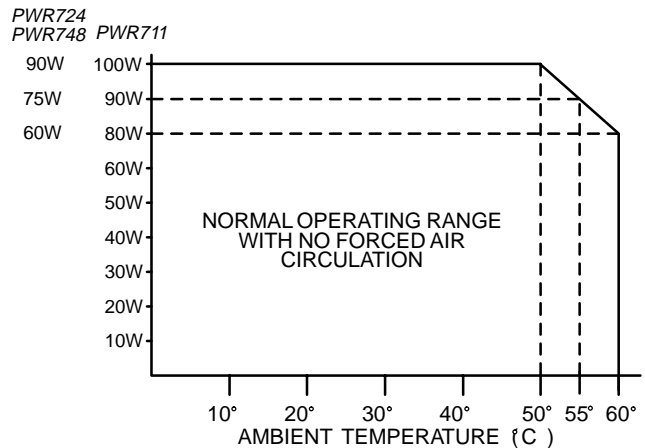

Installation

It is the responsibility of the OEM, system integrator, or end user to properly install the PLC equipment for safe and reliable operation. Product manuals provide detailed information about installation, startup, and proper use of the PLC equipment. The installation manual, shipped with your PLC programming software, describes how to properly install the equipment.

96 MHz, 32-Bit, Floating Point, 1 Mbyte Memory Central Processing Unit

GFK-1431F
November 1999

If the PLC installation must comply with supported standards, such as FCC or CE Directives, please refer to the *Installation Requirements for Conformance to Standards*, shipped with the PLC programming software, for additional guidelines.

Installation should not be attempted without referring to the applicable *Programmable Controller Installation Manual*.

- Connect the battery to either of the battery connectors on the module (see Figure 2).
- Put the toggle switch in the STOP position.
- Put the keyswitch in the *Memory Protection OFF* position.
- Make sure that rack power is off.
- Install the CPX 782 module in slot 1 of rack 0 (see Figure 1).
- Turn on power.

The module should power up and the top left (OK) LED should blink. When the diagnostics have completed successfully, the top left LED stays on and the second (RUN) and third (EN) LEDs are off. The fourth (bottom left) LED (MEM PROTECT) is off if the keyswitch is in the OFF position. The CPU is now ready to be programmed (if connected parallel, the CPU can be programmed regardless of key position).

After the program has been verified the toggle switch can be moved to the appropriate operation mode position; RUN WITH OUTPUTS ENABLED, RUN WITH OUTPUTS DISABLED, or STOP. The seven LEDs indicate the position of the toggle switch, memory protection status, status of serial port activity, and the state of the program.

Programmer Connection, Parallel

For a parallel interface (MS-DOS programmer only) the programmer is connected to the top port on the Bus Transmitter Module (IC697BEM713) as shown in Figure 1. Consult the applicable *Programming Software User's Manual* for a description of programming functions.

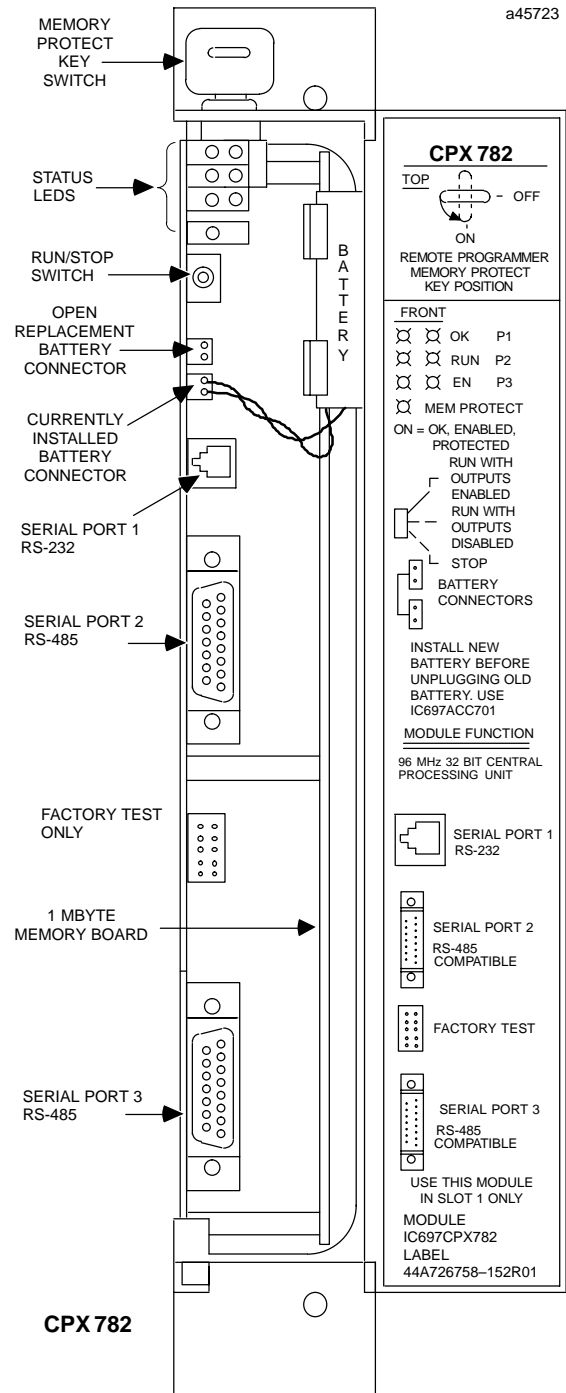

Figure 2. CPX 782 - Location of Major Features

GFK-1431F
November 1999

96 MHz, 32-Bit, Floating Point, 1 Mbyte Memory
Central Processing Unit

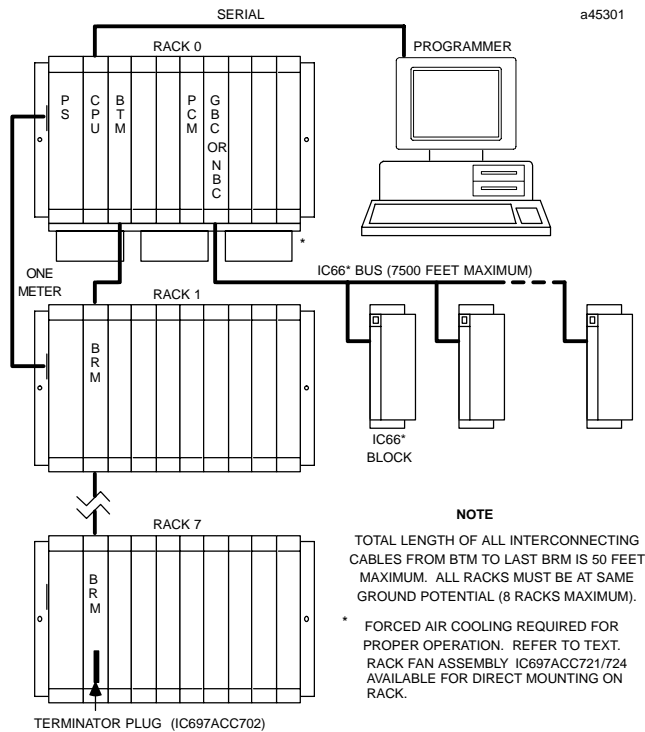

Figure 3. System Configuration, Serial Connection to Programmer

Programmer Connection, Serial Ports

The CPX 772 has three independent, on-board serial ports. These ports, accessed by connectors on the front of the module, are used for serial interface to a programming computer or other serial devices.

Starting with Firmware Release 8.00, support for program Load/Store operations and Datagrams was added to Ports 1 and 2. Also, Break-Free SNP was added as the default protocol for Ports 1 and 2 in Firmware Release 8.00. For details, see the *Important Product Information* sheet that ships with the module.

Protocols Supported

Protocol	Port 1	Port 2	Port 3
SNP (Slave)	Yes	Yes	Yes
Break-Free SNP (Slave)	Yes	Yes	No
SNPX	No	No	No
RTU	No	No	No

- Port 1, the top port, is RS-232 compatible. It has a 6-pin, female, RJ-11 connector, which is similar in appearance (although larger) to modular jacks commonly used for telephones and modems.

Table 1. Port 1 RS-232 Signals

Pin Number	Signal Name	Description
1 *	CTS	Clear To Send
2	TXD	Transmit Data
3	0V	Signal Ground
4	0V	Signal Ground
5	RXD	Receive Data
6	RTS	Request to Send

* Pin 1 is at the top of the connector as viewed from the front of the module.

- Port 2, the center port, is RS-485 compatible and is optocoupler isolated. Port 2 has a 15-pin, female D-connector.

Table 2. Port 2 RS-485 Signals

Pin Number	Signal Name	Description
1*	Shield	Cable Shield
2	NC	No Connection
3	NC	No Connection
4	NC	No Connection
5	+5VDC	Logic Power **
6	RTS(A)	Differential Request to Send
7	SG	Signal Ground
8	CTS(B')	Differential Clear To Send
9	RT	Resistor Termination
10	RD(A)	Differential Receive Data
11	RD(B')	Differential Receive Data
12	SD(A)	Differential Send Data
13	SD(B)	Differential Send Data
14	RTS(B')	Differential Request To Send
15	CTS(A)	Differential Clear To Send

* Pin 1 is at the bottom right of the connector as viewed from the front of the module.

** Note that Pin 5 provides Isolated +5 VDC power (100 mA maximum) for powering external options.

- Port 3, the bottom port, is also RS-485 compatible, but is not isolated. Port 3 has a 15-pin, female, D-connector. Pin-out information can be found in the *IC697 PLC Installation Manual*.

**96 MHz, 32-Bit, Floating Point, 1 Mbyte Memory
Central Processing Unit**GFK-1431F
November 1999

Three of the LED indicators on the front of the CPX 782 provide the status of serial port activity on the CPU without having a terminal connected. The LEDs are labeled as P1, P2, and P3 to correspond to the applicable port.

The connection from a CPU serial port to the serial port on a programming computer or other serial device requires a serial cable and, for Ports 2 and 3, a converter. This connection can be made with the IC690ACC901 cable kit (includes cable and miniconverter) or you may build cables to fit the needs of your particular application. See the *IC697 PLC Installation Manual* for more information on serial communications, cables, and converters.

Programmer Connection, Ethernet TCP/IP

Connecting your programmer via an Ethernet TCP/IP network requires installation of an Ethernet Interface module in the PLC. This can be either the Ethernet Controller, IC697CMM741, or Ethernet Interface (Type 2), IC697CMM742. Before connecting your programmer and PLC to the Ethernet TCP/IP network you must set the IP address in the Ethernet Interface. After setting the IP address, connect the

PLC and the programmer running Windows software to the Ethernet Interface. For more detailed information on the programmer connection via Ethernet TCP/IP, refer to the *TCP/IP Ethernet Communications (Type 2) User's Manual*, and the Windows programming manual, GFK-1295.

Configuration

The IC697 CPU and I/O system is configured with MS-DOS or Windows based programming software, although the MS-DOS software does not support all features, such as Bulk Memory Area (BMA), which requires the Windows software version 2.2 or later. See the IPI shipped with this module for programming software feature support details. There are no DIP switches or jumpers used to configure the system. The CPU verifies the actual module and rack configuration at power-up and periodically during operation. The actual configuration must be the same as the programmed configuration. Deviations are reported to the CPU alarm processor function for configured fault response. Refer to the applicable *Programming Software User's Manual* for a description of configuration functions.

GFK-1431F
November 1999

96 MHz, 32-Bit, Floating Point, 1 Mbyte Memory Central Processing Unit

Battery

A lithium battery (IC697ACC701) is installed as shown in Figure 2. This battery maintains program and data memory when power is removed and operates the calendar clock. Be sure to install the new battery before removing the old battery. Specific indication of a low battery state is detailed in the applicable *Programmable Controller Reference Manual*.

- Grasp the board firmly at the top and bottom of the board cover with your thumbs on the front of the cover and your fingers on the plastic clips on the back of the cover.
- Squeeze the rack clips on the back of the cover with your fingers to disengage the clip from the rack rail and pull the board firmly to remove it from the backplane connector.
- Slide the board along the card guide and remove it from the rack.

Removing a Module

The instructions listed below should be followed when removing a module from its slot in a rack.

Table 3. Specifications for IC697CPX782 †

Battery: Shelf life	5 years at 20° C (68° F)
Battery: Memory retention	6 months nominal without applied power.
Current required from 5V bus	3.1 Amps nominal
Operating Temperature	0 to 60°C (32°F to 140°F)
Time of Day Clock accuracy	" 3.5 seconds per day maximum
Elapsed Time Clock (internal timing) accuracy	" .01% maximum
Serial Ports Port 1: RS-232 compatible Port 2: RS-485 compatible (optocoupler isolated) Port 3: RS-485 compatible (not isolated)	Programmer Serial Attachment, or other serial devices Protocols supported: SNP Slave only
VME Compatibility	System designed to support the VME standard C.1

† Refer to GFK-0867B, or later for product standards and general specifications. For installations requiring compliance to more stringent requirements (for example, FCC or European Union Directives), refer to *Installation Requirements for Conformance to Standards*.

Table 4. Ordering Information

Description	Catalog Number
Central Processing Unit 96 MHz, 32-Bit, Floating Point, 1 Mbyte Memory	IC697CPX782
Lithium Battery	IC697ACC701
Rack Fan Assembly, 120 VAC	IC697ACC721
Rack Fan Assembly, 240 VAC	IC697ACC724
Rack Fan Assembly, 24 VDC	IC697ACC744

Note: For Conformal Coat option, please consult the factory for price and availability.

GFK-1433E
November 1999

96 MHz, 32-Bit, Floating Point, 6 Mbyte (Medium) Memory Central Processing Unit

Features

- Single slot CPU with three serial ports
- Provides 6 Mbytes of battery-backed memory in the same slot
- Contains 256K of non-volatile user flash memory
- Supports BMA in release 7.92 and later
- Supports floating point calculations
- 12K inputs and outputs (any mix), and up to 8K analog I/O
- 0.4 microseconds per boolean function
- 96 MHz, 80486DX4 microprocessor
- Supports IC666 (can be IC660 or IC661) and IC697 I/O
- Programmed by MS-DOS® software products, or Windows® based software products running on Windows® 95 or Windows NT® over Ethernet TCP/IP or through an SNP port
- Configurable data and program memory
- Battery-backed calendar clock
- Three position operation mode switch
- Password controlled access
- Remote programmer keyswitch memory protection
- Seven status LEDs
- Software configuration (No DIP switches or jumpers)
- Reference information inside front door
- In-system upgradable firmware

Functions

The CPX 928 is a single slot PLC CPU that is programmed and configured by MS-DOS or Windows based programming software to perform real time control of machines, processes and material handling systems. It communicates with I/O and smart option modules over the rack-mounted backplane using the VME C.1 Standard format.

Supported option modules include LAN Interface modules, Programmable Coprocessor, Alphanumeric Display Coprocessor, Bus Controller for IC660/661 I/O products, Communications modules, I/O Link Interface, and all of the IC697 family of discrete and analog I/O modules.

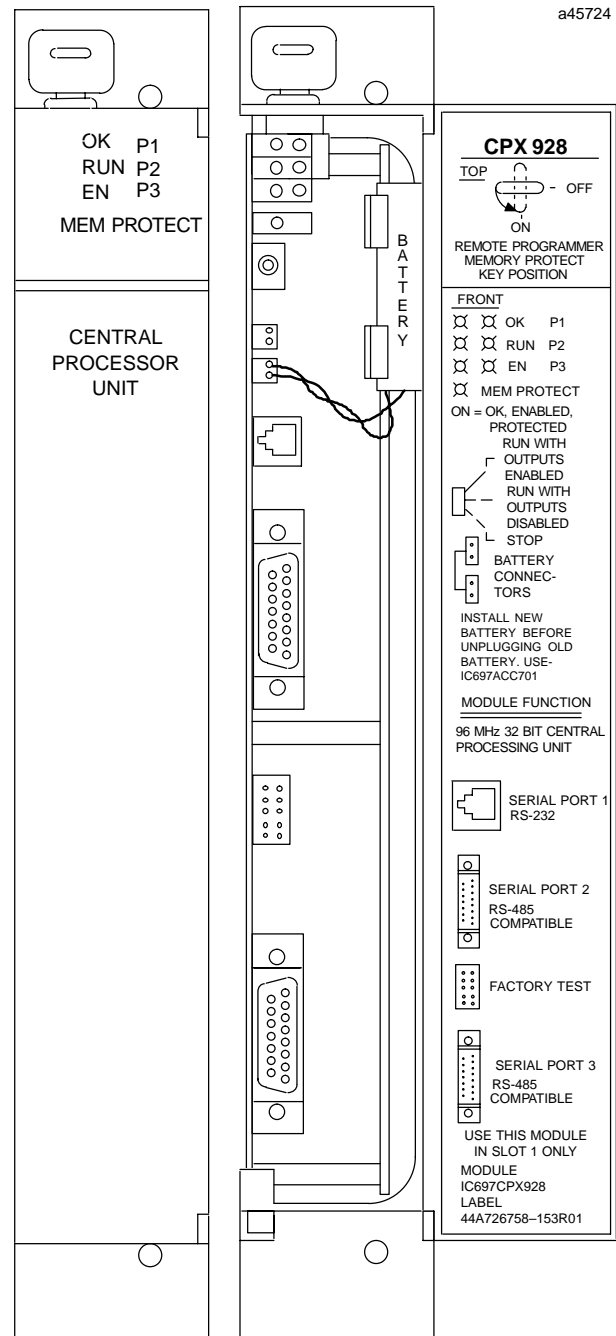

© MS-DOS, Windows, Windows 95, and Windows NT are registered trademarks of Microsoft Corporation.

GFK-1433E
November 1999

96 MHz, 32-Bit, Floating Point, 6 Mbyte (Medium) Memory Central Processing Unit

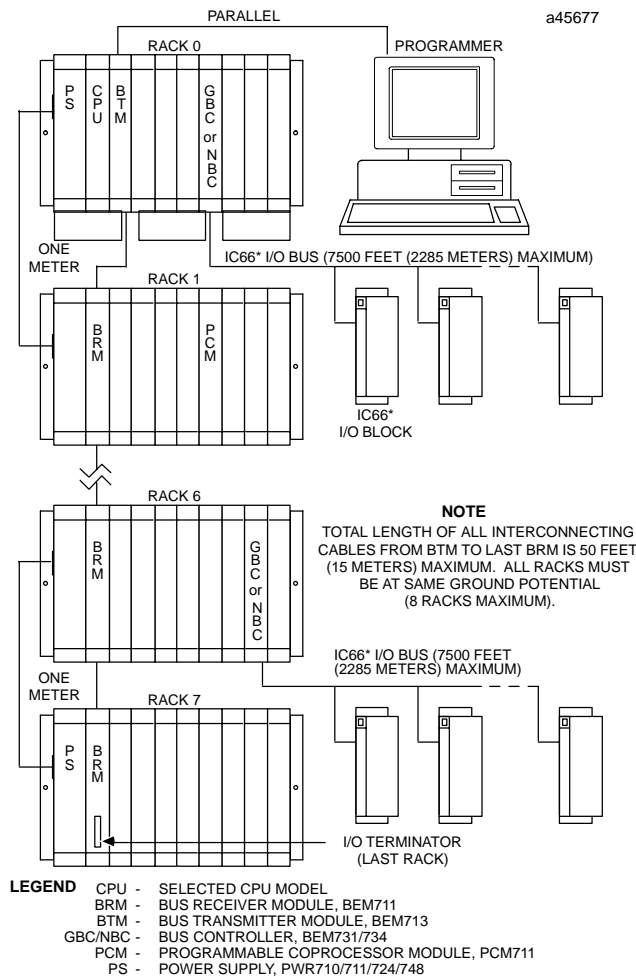

Figure 1. PLC System Configuration Example

User RAM Memory

The CPX928 has a built-in memory board with 6 Mbytes of battery-backed CMOS RAM memory for user data (program, configuration, and register data) storage.

User Flash Memory

The CPX928 has 256K of built-in, non-volatile flash memory for user data (program, configuration, and register data) storage. Use of this flash memory is optional.

Firmware Storage in Flash Memory

This CPU uses flash memory for storing the operating system firmware. This allows firmware to be updated

without disassembling the module or replacing EPROMs. The operating system firmware is updated by connecting a PC compatible computer to the module's serial port and running the software included with the firmware upgrade kit.

Operation, Protection, and Module Status

Operation of this module can be controlled by the three-position RUN/STOP switch or remotely by an attached programmer and programming software. Program and configuration data can be locked through software passwords or manually by the memory protect keyswitch. When the key is in the *protected* position, program and configuration data can only be changed by a programmer connected parallel only (to the Bus Transmitter module). The status of a CPU is indicated by the seven green LEDs on the front of the module.

Operating Temperature

The CPX 928 requires forced air cooling for proper operation in ambient temperatures greater than 50°C (122°F). A fan capable of 70 CFM (including filters) should be located beneath slot 1 of the rack containing the CPU.

Fan assemblies (IC697ACC 721, IC697ACC724, and IC697ACC744) can be ordered for direct mounting on the IC697 rack. Refer to the applicable *Programmable Controller Installation Manual* for detailed information.

Installation

It is the responsibility of the OEM, system integrator, or end user to properly install the PLC equipment for safe and reliable operation. Product manuals provide detailed information about installation, startup, and proper use of the PLC equipment. The installation manual, shipped with your PLC programming software, describes how to properly install the equipment.

If the PLC installation must comply with supported standards, such as FCC or CE Directives, please refer to the *Installation Requirements for Conformance to Standards*, shipped with the PLC programming software, for additional guidelines.

**96 MHz, 32-Bit, Floating Point, 6 Mbyte (Medium) Memory
Central Processing Unit**

GFK-1433E
November 1999

- Installation should not be attempted without referring to the applicable *Programmable Controller Installation Manual*.
- Connect the battery to either of the battery connectors on the module (see Figure 2).
- Put the toggle switch in the STOP position.
- Put the keyswitch in the *Memory Protection OFF* position.
- Make sure that rack power is off.
- Install the CPX 928 module in slot 1 of rack 0 (see Figure 1).
- Turn on power.

The module should power up and the top left (OK) LED should blink. When the diagnostics have completed successfully, the top left LED stays on and the second (RUN) and third (EN) LEDs are off. The fourth (bottom left) LED (MEM PROTECT) is off if the keyswitch is in the OFF position. The CPU is now ready to be programmed (if connected parallel, the CPU can be programmed regardless of key position).

After the program has been verified the toggle switch can be moved to the appropriate operation mode position; RUN WITH OUTPUTS ENABLED, RUN WITH OUTPUTS DISABLED, or STOP. The seven LEDs indicate the position of the toggle switch, memory protection status, status of serial port activity, and the state of the program.

Programmer Connection, Parallel

For a parallel interface (MS-DOS programmer only) the programmer is connected to the top port on the Bus Transmitter Module (IC697BEM713) as shown in Figure 1. Consult the applicable *Programming Software User's Manual* for a description of programming functions.

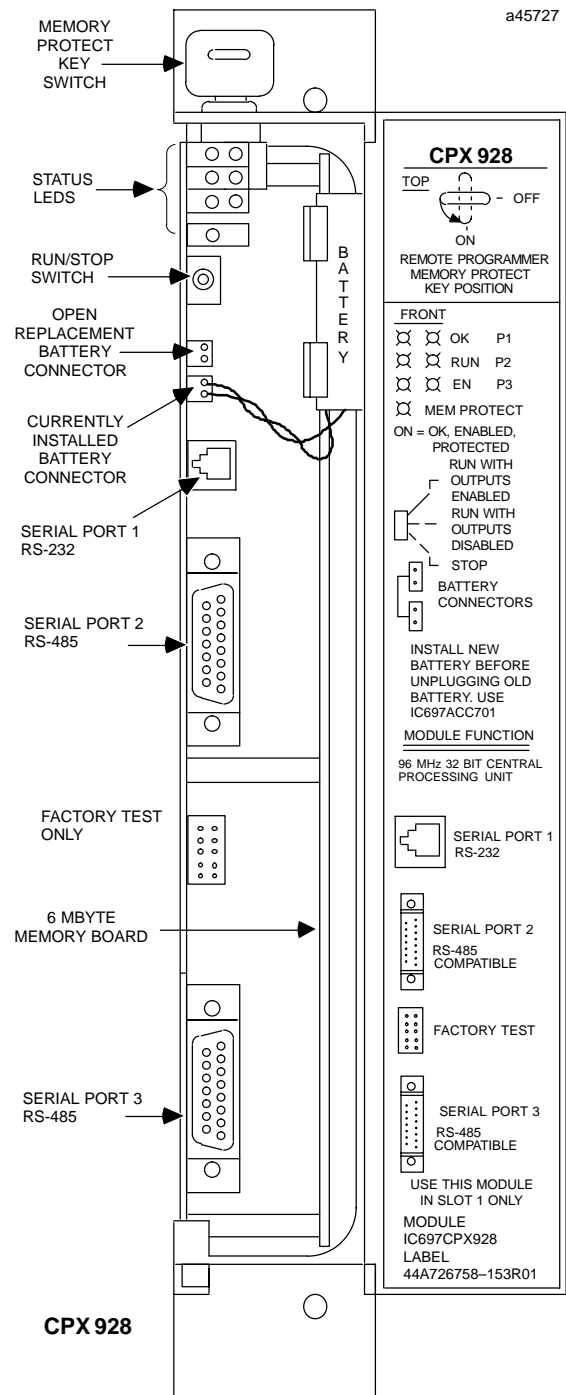

Figure 2. CPX 928 - Location of Major Features

GFK-1433E
November 1999

**96 MHz, 32-Bit, Floating Point, 6 Mbyte (Medium) Memory
Central Processing Unit**

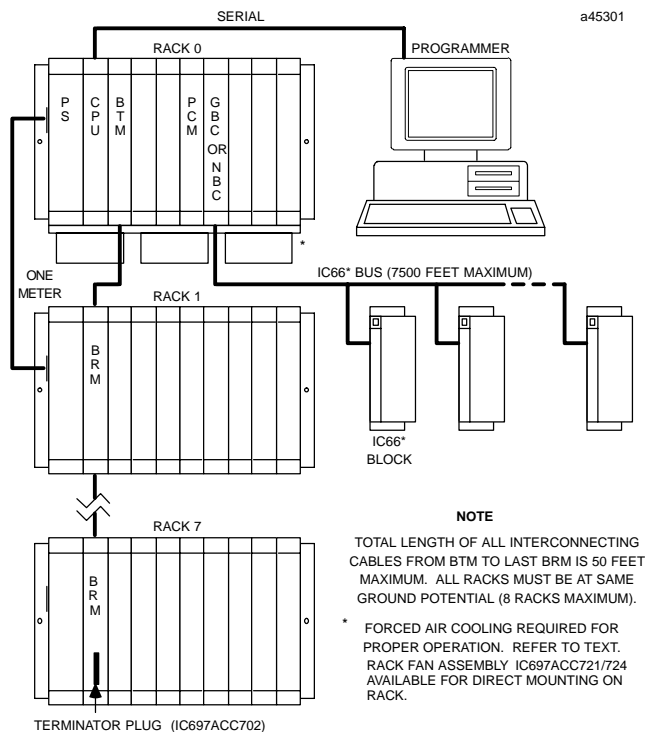

Figure 3. System Configuration, Serial Connection to Programmer

Programmer Connection, Serial Ports

The CPX 772 has three independent, on-board serial ports. These ports, accessed by connectors on the front of the module, are used for serial interface to a programming computer or other serial devices.

Starting with Firmware Release 8.00, support for program Load/Store operations and Datagrams was added to Ports 1 and 2. Also, Break-Free SNP was added as the default protocol for Ports 1 and 2 in Firmware Release 8.00. For details, see the *Important Product Information* sheet that ships with the module.

Protocols Supported

Protocol	Port 1	Port 2	Port 3
SNP (Slave)	Yes	Yes	Yes
Break-Free SNP (Slave)	Yes	Yes	No
SNPX	No	No	No
RTU	No	No	No

- **Port 1**, the top port, is RS-232 compatible. It has a 6-pin, female, RJ-11 connector, which is similar in appearance (although larger) to modular jacks commonly used for telephones and modems.

Table 1. Port 1 RS-232 Signals

Pin Number	Signal Name	Description
1 *	CTS	Clear To Send
2	TXD	Transmit Data
3	0V	Signal Ground
4	0V	Signal Ground
5	RXD	Receive Data
6	RTS	Request to Send

* Pin 1 is at the top of the connector as viewed from the front of the module.

- **Port 2**, the center port, is RS-485 compatible and is optocoupler isolated. Port 2 has a 15-pin, female D-connector.

Table 2. Port 2 RS-485 Signals

Pin Number	Signal Name	Description
1*	Shield	Cable Shield
2	NC	No Connection
3	NC	No Connection
4	NC	No Connection
5	+5VDC	Logic Power **
6	RTS(A)	Differential Request to Send
7	SG	Signal Ground
8	CTS(B')	Differential Clear To Send
9	RT	Resistor Termination
10	RD(A)	Differential Receive Data
11	RD(B')	Differential Receive Data
12	SD(A)	Differential Send Data
13	SD(B)	Differential Send Data
14	RTS(B')	Differential Request To Send
15	CTS(A)	Differential Clear To Send

*Pin 1 is at the bottom right of the connector as viewed from the front of the module.

** Note that Pin 5 provides Isolated +5 VDC power (100 mA maximum) for powering external options.

- **Port 3**, the bottom port, is also RS-485 compatible, but is not isolated. Port 3 has a 15-pin, female D-connector. Pin-out information can be found in the *IC697 PLC Installation Manual*.

**96 MHz, 32-Bit, Floating Point, 6 Mbyte (Medium) Memory
Central Processing Unit**GFK-1433E
November 1999

Three of the LED indicators on the front of the CPX 928 provide the status of serial port activity on the CPU without having a terminal connected. The LEDs are labeled as P1, P2, and P3 to correspond to the applicable port.

The connection from a CPU serial port to the serial port on a programming computer or other serial device requires a serial cable and, for Ports 2 and 3, a converter. This connection can be made with the IC690ACC901 cable kit (includes cable and miniconverter) or you may build cables to fit the needs of your particular application. See the *IC697 PLC Installation Manual* for more information on serial communications, cables, and converters.

Programmer Connection, Ethernet TCP/IP

Connecting your programmer via an Ethernet TCP/IP network requires installation of an Ethernet Interface module in the PLC. This can be either the Ethernet Controller, IC697CMM741, or Ethernet Interface (Type 2), IC697CMM742. Before connecting your programmer and PLC to the Ethernet TCP/IP network you must set the IP address in the Ethernet Interface. After setting the IP address, connect the

PLC and the programmer running Windows software to the Ethernet Interface. For more detailed information on the programmer connection via Ethernet TCP/IP, refer to the *TCP/IP Ethernet Communications (Type 2) User's Manual*, and the Windows programming manual, GFK-1295.

Configuration

The IC697 CPU and I/O system is configured with MS-DOS or Windows based programming software, although the MS-DOS software does not support all features, such as Bulk Memory Area (BMA), which requires the Windows software version 2.2 or later. See the IPI shipped with this module for programming software feature support details. There are no DIP switches or jumpers used to configure the system. The CPU verifies the actual module and rack configuration at power-up and periodically during operation. The actual configuration must be the same as the programmed configuration. Deviations are reported to the CPU alarm processor function for configured fault response. Refer to the applicable *Programming Software User's Manual* for a description of configuration functions.

GFK-1433E
November 1999

96 MHz, 32-Bit, Floating Point, 6 Mbyte (Medium) Memory Central Processing Unit

Battery

A lithium battery (IC697ACC701) is installed as shown in Figure 2. This battery maintains program and data memory when power is removed and operates the calendar clock. Be sure to install the new battery before removing the old battery. Specific indication of a low battery state is detailed in the applicable *Programmable Controller Reference Manual*.

- Grasp the board firmly at the top and bottom of the board cover with your thumbs on the front of the cover and your fingers on the plastic clips on the back of the cover.
- Squeeze the rack clips on the back of the cover with your fingers to disengage the clip from the rack rail and pull the board firmly to remove it from the backplane connector.
- Slide the board along the card guide and remove it from the rack.

Removing a Module

The instructions listed below should be followed when removing a module from its slot in a rack.

Table 3. Specifications for IC697CPX928 †

Battery: Shelf life	5 years at 20° C (68° F)
Battery: Memory retention	6 months nominal without applied power.
Current required from 5V bus	3.1 Amps nominal
Operating Temperature	0 to 60°C (32°F to 140°F); 70 CFM forced air required 0 to 50°C (32°F to 122°F); without forced air
Time of Day Clock accuracy	" 3.5 seconds per day maximum
Elapsed Time Clock (internal timing) accuracy	" .01% maximum
Serial Ports Port 1: RS-232 compatible Port 2: RS-485 compatible (optocoupler isolated) Port 3: RS-485 compatible (not isolated)	Programmer Serial Attachment, or other serial devices Protocols supported: SNP Slave only
VME Compatibility	System designed to support the VME standard C.1

† Refer to GFK-0867B, or later for product standards and general specifications. For installations requiring compliance to more stringent requirements (for example, FCC or European Union Directives), refer to *Installation Requirements for Conformance to Standards*.

Table 4. Ordering Information

Description	Catalog Number
Central Processing Unit 96 MHz, 32-Bit, Floating Point, 6 Mbyte Memory	IC697CPX928
Lithium Battery	IC697ACC701
Rack Fan Assembly, 120 VAC	IC697ACC721
Rack Fan Assembly, 240 VAC	IC697ACC724
Rack Fan Assembly, 24 VDC	IC697ACC744

Note: For Conformal Coat option, please consult the factory for price and availability.

GFK-1435E
November 1999

96 MHz, 32-Bit, Floating Point, 1 Mbyte Fast Memory Central Processing Unit

Features

- Single slot CPU with three serial ports
- Provides 1 Mbyte of battery-backed memory in the same slot
- Contains 256K of non-volatile user flash memory
- Supports BMA in release 7.92 and later
- Supports floating point calculations
- 12K inputs and outputs (any mix), and up to 8K analog I/O
- 0.4 microseconds per boolean function
- 96 MHz, 80486DX4 microprocessor
- Supports IC666 (can be IC660 or IC661) and IC697 I/O
- Programmed by MS-DOS® software products, or Windows® based software products running on Windows® 95 or Windows NT® over Ethernet TCP/IP or through an SNP port
- Configurable data and program memory
- Battery-backed calendar clock
- Three position operation mode switch
- Password controlled access
- Remote programmer keyswitch memory protection
- Seven status LEDs
- Software configuration (No DIP switches or jumpers)
- Reference information inside front door
- In-system upgradable firmware

Functions

The CPX 935 is a single slot PLC CPU that is programmed and configured by MS-DOS or Windows based programming software to perform real time control of machines, processes, and material handling systems. It communicates with I/O and smart option modules over a rack mounted backplane using the VME C.1 Standard format.

Supported option modules include LAN Interface modules, Programmable Coprocessor, Alphanumeric Display Coprocessor, Bus Controller for IC660/661 I/O products, Communications modules, I/O Link Interface, and all of the IC697 family of discrete and analog I/O modules.

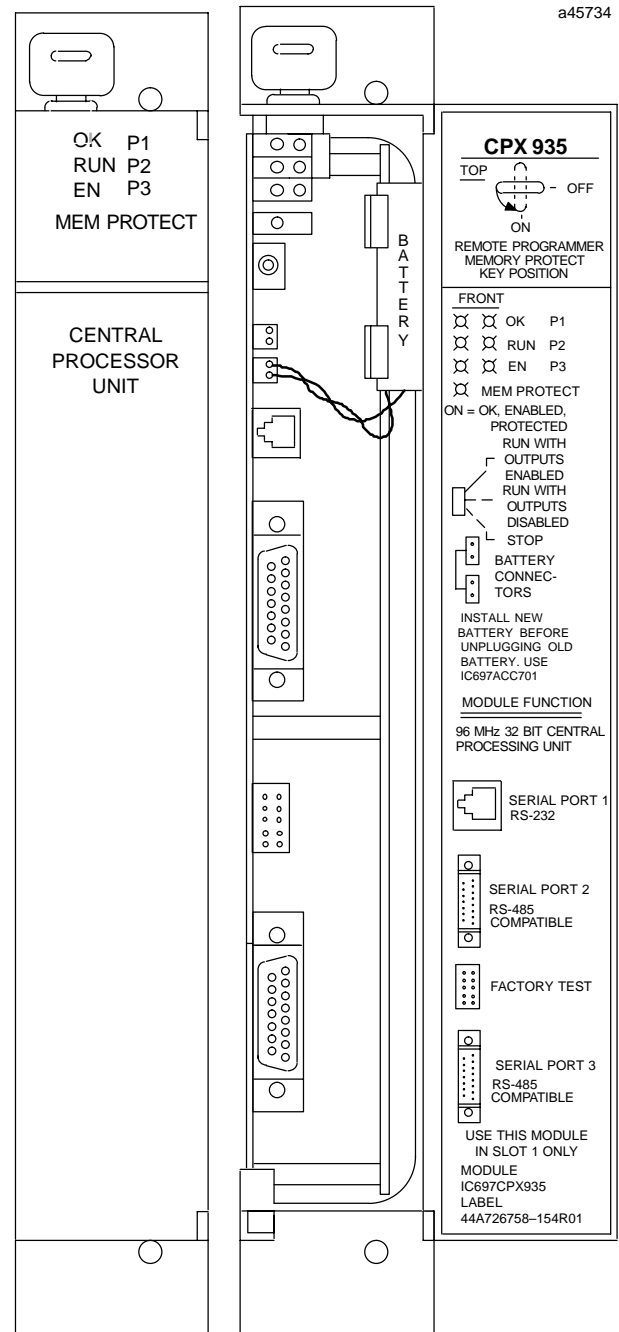

© MS-DOS, Windows, Windows 95, and Windows NT are registered trademarks of Microsoft Corporation.

GFK-1435E
November 1999

96 MHz, 32-Bit, Floating Point, 1 Mbyte Fast Memory Central Processing Unit

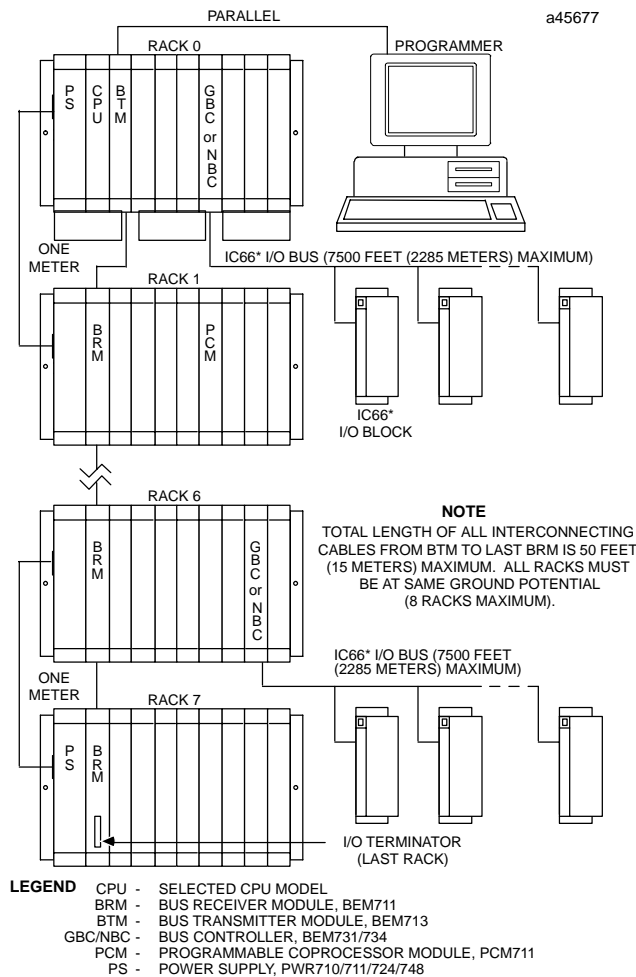

Figure 1. PLC System Configuration Example

User RAM Memory

The CPX935 has a built-in memory board with 1 Mbyte of battery-backed Fast CMOS RAM memory for user data (program, configuration, and register data) storage.

User Flash Memory

The CPX935 has 256K of built-in, non-volatile flash memory for user data (program, configuration, and register data) storage. Use of this flash memory is optional.

Firmware Storage in Flash Memory

This CPU uses non-volatile flash memory for storing the operating system firmware. This allows firmware

to be updated without disassembling the module or replacing EPROMs. The operating system firmware is updated by connecting a PC compatible computer to the module's serial port and running the software included with the firmware upgrade kit.

Operation, Protection, and Module Status

Operation of this module can be controlled by the three-position RUN/STOP switch or remotely by an attached programmer and programming software. Program and configuration data can be locked through software passwords or manually by the memory protect keyswitch. When the key is in the *protected* position, program and configuration data can only be changed by a programmer connected parallel only (to the Bus Transmitter module). The status of a CPU is indicated by the seven green LEDs on the front of the module.

Operating Temperature

The CPX 935 requires forced air cooling for proper operation in ambient temperatures greater than 50°C (122°F). A fan capable of 70 CFM (including filters) should be located beneath slot 1 of the rack containing the CPU.

Fan assemblies (IC697ACC 721, IC697ACC724, and IC697ACC744) can be ordered for direct mounting on the IC697 rack. Refer to the applicable *Programmable Controller Installation Manual* for detailed information.

Installation

It is the responsibility of the OEM, system integrator, or end user to properly install the PLC equipment for safe and reliable operation. Product manuals provide detailed information about installation, startup, and proper use of the PLC equipment. The installation manual, shipped with your PLC programming software, describes how to properly install the equipment.

If the PLC installation must comply with supported standards, such as FCC or CE Directives, please refer to the *Installation Requirements for Conformance to Standards*, shipped with the PLC programming software, for additional guidelines.

**96 MHz, 32-Bit, Floating Point, 1 Mbyte Fast Memory
Central Processing Unit**

GFK-1435E
November 1999

- Installation should not be attempted without referring to the applicable *Programmable Controller Installation Manual*.
- Connect the battery to either of the battery connectors on the module (see Figure 2).
- Put the toggle switch in the STOP position.
- Put the keyswitch in the *Memory Protection OFF* position.
- Make sure that rack power is off.
- Install the CPX 935 module in slot 1 of rack 0 (see Figure 1).
- Turn on power.

The module should power up and the top left (OK) LED should blink. When the diagnostics have completed successfully, the top left LED stays on and the second (RUN) and third (EN) LEDs are off. The fourth (bottom left) LED (MEM PROTECT) is off if the keyswitch is in the OFF position. The CPU is now ready to be programmed (if connected parallel, the CPU can be programmed regardless of key position).

After the program has been verified the toggle switch can be moved to the appropriate operation mode position; RUN WITH OUTPUTS ENABLED, RUN WITH OUTPUTS DISABLED, or STOP. The seven LEDs indicate the position of the toggle switch, memory protection status, status of serial port activity, and the state of the program.

Programmer Connection, Parallel

For a parallel interface (MS-DOS programmer only) the programmer is connected to the top port on the Bus Transmitter Module (IC697BEM713) as shown in Figure 1. Consult the applicable *Programming Software User's Manual* for a description of programming functions.

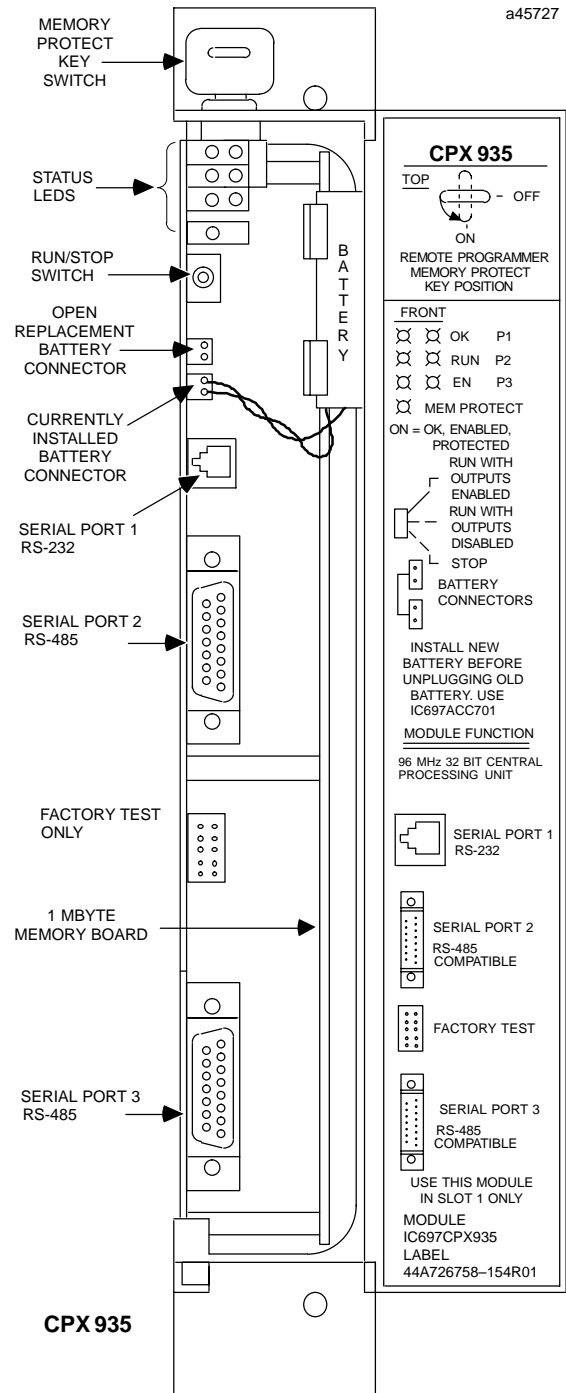

Figure 2. CPX 935 - Location of Major Features

GFK-1435E
November 1999

**96 MHz, 32-Bit, Floating Point, 1 Mbyte Fast Memory
Central Processing Unit**

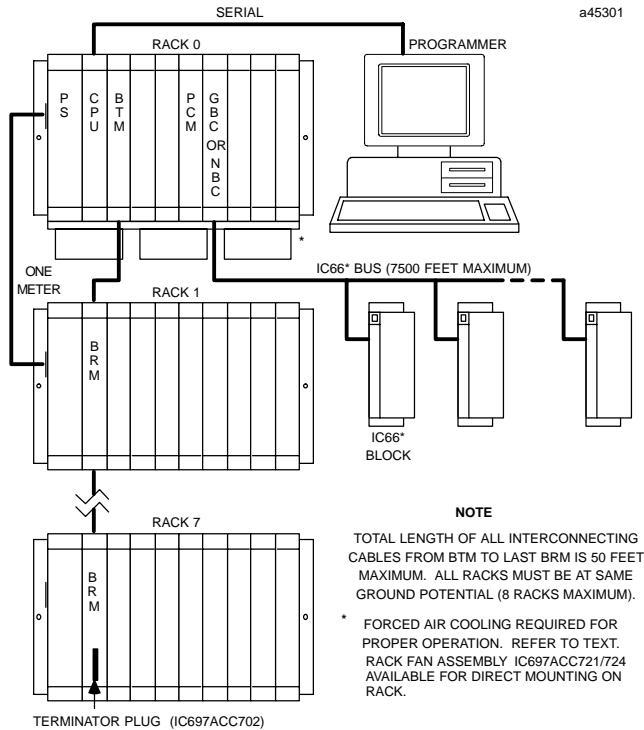

Figure 3. System Configuration, Serial Connection to Programmer

Programmer Connection, Serial Ports

The CPX 772 has three independent, on-board serial ports. These ports, accessed by connectors on the front of the module, are used for serial interface to a programming computer or other serial devices.

Starting with Firmware Release 8.00, support for program Load/Store operations and Datagrams was added to Ports 1 and 2. Also, Break-Free SNP was added as the default protocol for Ports 1 and 2 in Firmware Release 8.00. For details, see the *Important Product Information* sheet that ships with the module.

Protocols Supported

Protocol	Port 1	Port 2	Port 3
SNP (Slave)	Yes	Yes	Yes
Break-Free SNP (Slave)	Yes	Yes	No
SNPX	No	No	No
RTU	No	No	No

- **Port 1**, the top port, is RS-232 compatible. It has a 6-pin, female, RJ-11 connector, which is similar in appearance (although larger) to modular jacks commonly used for telephones and modems.

Table 10-1. Port 1 RS-232 Signals

Pin Number	Signal Name	Description
1 *	CTS	Clear To Send
2	TXD	Transmit Data
3	0V	Signal Ground
4	0V	Signal Ground
5	RXD	Receive Data
6	RTS	Request to Send

* Pin 1 is at the top of the connector as viewed from the front of the module.

- **Port 2**, the center port, is RS-485 compatible and is optocoupler isolated. Port 2 has a 15-pin, female D-connector.

Table 10-2. Port 2 RS-485 Signals

Pin Number	Signal Name	Description
1*	Shield	Cable Shield
2	NC	No Connection
3	NC	No Connection
4	NC	No Connection
5	+5VDC	Logic Power **
6	RTS(A)	Differential Request to Send
7	SG	Signal Ground
8	CTS(B')	Differential Clear To Send
9	RT	Resistor Termination
10	RD(A)	Differential Receive Data
11	RD(B')	Differential Receive Data
12	SD(A)	Differential Send Data
13	SD(B)	Differential Send Data
14	RTS(B')	Differential Request To Send
15	CTS(A)	Differential Clear To Send

*Pin 1 is at the bottom right of the connector as viewed from the front of the module.

** Note that Pin 5 provides Isolated +5 VDC power (100 mA maximum) for powering external options.

- **Port 3**, the bottom port, is also RS-485 compatible, but is not isolated. Port 3 has a 15-pin, female D-connector. Pin-out information can be found in the *IC697 PLC Installation Manual*.

**96 MHz, 32-Bit, Floating Point, 1 Mbyte Fast Memory
Central Processing Unit**GFK-1435E
November 1999

Three of the LED indicators on the front of the CPX935 provide the status of serial port activity on the CPU without having a terminal connected. The LEDs are labeled as P1, P2, and P3 to correspond to the applicable port.

The connection from a CPU serial port to the serial port on a programming computer or other serial device requires a serial cable and, for Ports 2 and 3, a converter. This connection can be made with the IC690ACC901 cable kit (includes cable and miniconverter) or you may build cables to fit the needs of your particular application. See the *IC697 PLC Installation Manual* for more information on serial communications, cables, and converters.

Programmer Connection, Ethernet TCP/IP

Connecting your programmer via an Ethernet TCP/IP network requires installation of an Ethernet Interface module in the PLC. This can be either the Ethernet Controller, IC697CMM741, or Ethernet Interface (Type 2), IC697CMM742. Before connecting your programmer and PLC to the Ethernet TCP/IP network you must set the IP address in the Ethernet Interface. After setting the IP address, connect the

PLC and the programmer running Windows software to the Ethernet Interface. For more detailed information on the programmer connection via Ethernet TCP/IP, refer to the *TCP/IP Ethernet Communications (Type 2) User's Manual*, and the Windows programming manual, GFK-1295.

Configuration

The IC697 CPU and I/O system is configured with MS-DOS or Windows based programming software, although the MS-DOS software does not support all features, such as Bulk Memory Area (BMA), which requires the Windows software version 2.2 or later. See the IPI shipped with this module for programming software feature support details. There are no DIP switches or jumpers used to configure the system. The CPU verifies the actual module and rack configuration at power-up and periodically during operation. The actual configuration must be the same as the programmed configuration. Deviations are reported to the CPU alarm processor function for configured fault response. Refer to the applicable *Programming Software User's Manual* for a description of configuration functions.

GFK-1435E
November 1999

96 MHz, 32-Bit, Floating Point, 1 Mbyte Fast Memory Central Processing Unit

Battery

A lithium battery (IC697ACC701) is installed as shown in Figure 2. This battery maintains program and data memory when power is removed and operates the calendar clock. Be sure to install the new battery before removing the old battery. Specific indication of a low battery state is detailed in the applicable *Programmable Controller Reference Manual*.

Removing a Module

The instructions listed below should be followed when removing a module from its slot in a rack.

- Grasp the board firmly at the top and bottom of the board cover with your thumbs on the front of the cover and your fingers on the plastic clips on the back of the cover.
- Squeeze the rack clips on the back of the cover with your fingers to disengage the clip from the rack rail and pull the board firmly to remove it from the backplane connector.
- Slide the board along the card guide and remove it from the rack.

Table 1. Specifications for IC697CPX935 †

Battery: Shelf life	5 years at 20° C (68° F)
Battery: Memory retention	6 months nominal without applied power.
Current required from 5V bus	3.1 Amps nominal
Operating Temperature	0 to 60°C (32°F to 140°F); 70 CFM forced air required 0 to 50°C (32°F to 122°F); without forced air
Time of Day Clock accuracy	" 3.5 seconds per day maximum
Elapsed Time Clock (internal timing) accuracy	" .01% maximum
Serial Ports Port 1: RS-232 compatible Port 2: RS-485 compatible (optocoupler isolated) Port 3: RS-485 compatible (not isolated)	Programmer Serial Attachment, or other serial devices Protocols supported: SNP Slave only
VME Compatibility	System designed to support the VME standard C.1

† Refer to GFK-0867B, or later for product standards and general specifications. For installations requiring compliance to more stringent requirements (for example, FCC or European Union Directives), refer to *Installation Requirements for Conformance to Standards*.

Table 2. Ordering Information

Description	Catalog Number
Central Processing Unit 96 MHz, 32-Bit, Floating Point, 1 Mbyte Fast Memory	IC697CPX935
Lithium Battery	IC697ACC701
Rack Fan Assembly, 120 VAC	IC697ACC721
Rack Fan Assembly, 240 VAC	IC697ACC724
Rack Fan Assembly, 24 VDC	IC697ACC744

Note: For Conformal Coat option, please consult the factory for price and availability.

November 1999

96 MHz, 32-Bit Floating Point, 512 KByte Memory Central Processing Unit for CPU Redundancy Applications

Features

- Required for CPU redundancy applications
- Supports floating point calculations
- Single slot CPU
- 2048 inputs and 2048 outputs
- Up to 8K analog I/O
- 0.4 microseconds per boolean function
- 96MHz, 80486DX4 microprocessor
- Supports IC660/IC661 and IC697I/O products
- Programmed by MS-DOS® (IC641) or Windows® based software products
- Supports 512 Kbytes of battery-backed fast CMOS RAM memory in the same slot
- Configurable data and program memory
- Battery-backed calendar clock
- Three position operation mode switch
- Password controlled access
- Keyswitch memory protection
- Seven status LEDs
- Software configuration (No DIP switches or jumpers to set)
- Reference information inside front door
- Three Series 90 Protocol (SNP) ports

Redundancy Features

In addition to the above features, the CGR772 supports the redundancy features listed below.

- Bumpless switching between redundancy PLCs
- Synchronization of CPUs
- Redundant backup communications
- 5.9 ms scan extension (nominal)
- One scan switching (in most cases)
- Configurable backup data size
- On-line programming
- On-line repair
- No single point of failure (except for IC66* I/O Blocks and bus stubs).
- Same or different program in Primary and Secondary PLCs
- Program control switching
- Symptom status bits and fault tables
- Memory parity and checksums
- Common I/O on IC660/IC661 bus

- Manual switching with pushbutton switch on Redundancy Communications Module

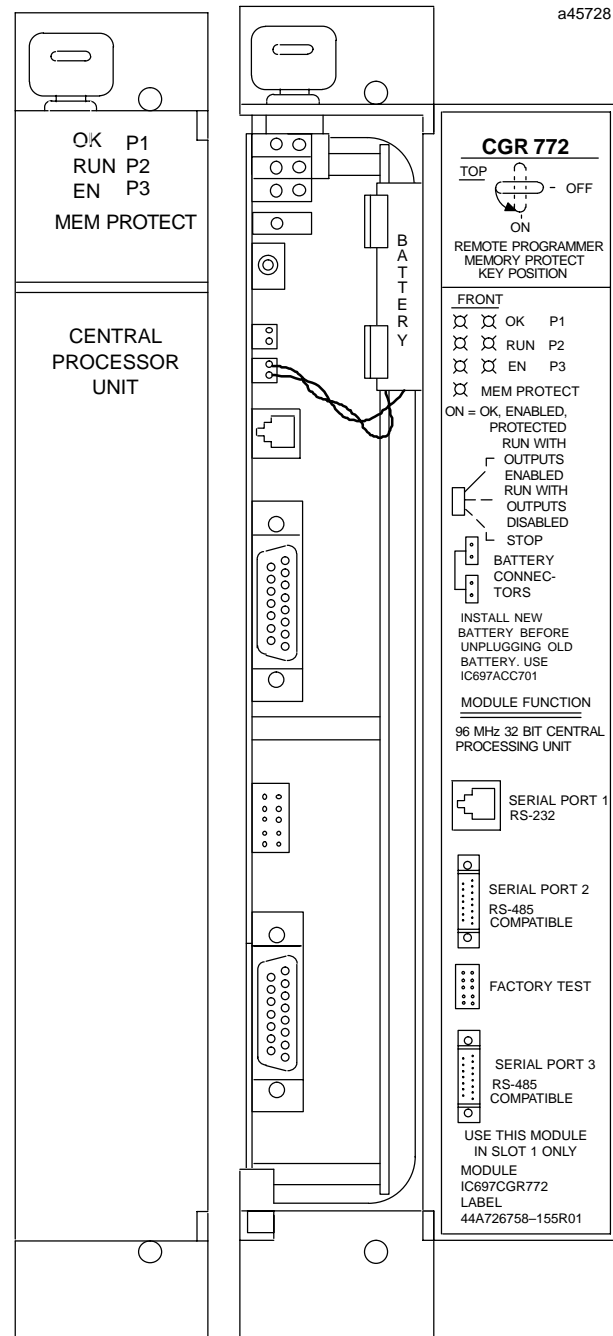

© MS-DOS and Windows are registered trademarks of Microsoft Corporation

November 1999

96 MHz, 32-Bit Floating Point, 512 KByte Memory Central Processing Unit for CPU Redundancy Applications

Functions

The CGR 772 is a single slot programmable controller CPU which allows floating point calculations and is required for CPU redundancy applications. The CGR772 is programmed and configured by MS-DOS or Windows programming software to perform real time control of machines, processes and material handling systems.

The CGR772 communicates with I/O and smart option (specialty) modules over the rack mounted backplane (IC697CHS750, 790, 791) by way of the VME C.1 Standard format.

Supported option modules include all IC697 LAN interface modules, several Coprocessor modules, Bus Controller for IC660/IC661 I/O, Communications modules, and all of the IC697 family of discrete and analog I/O modules.

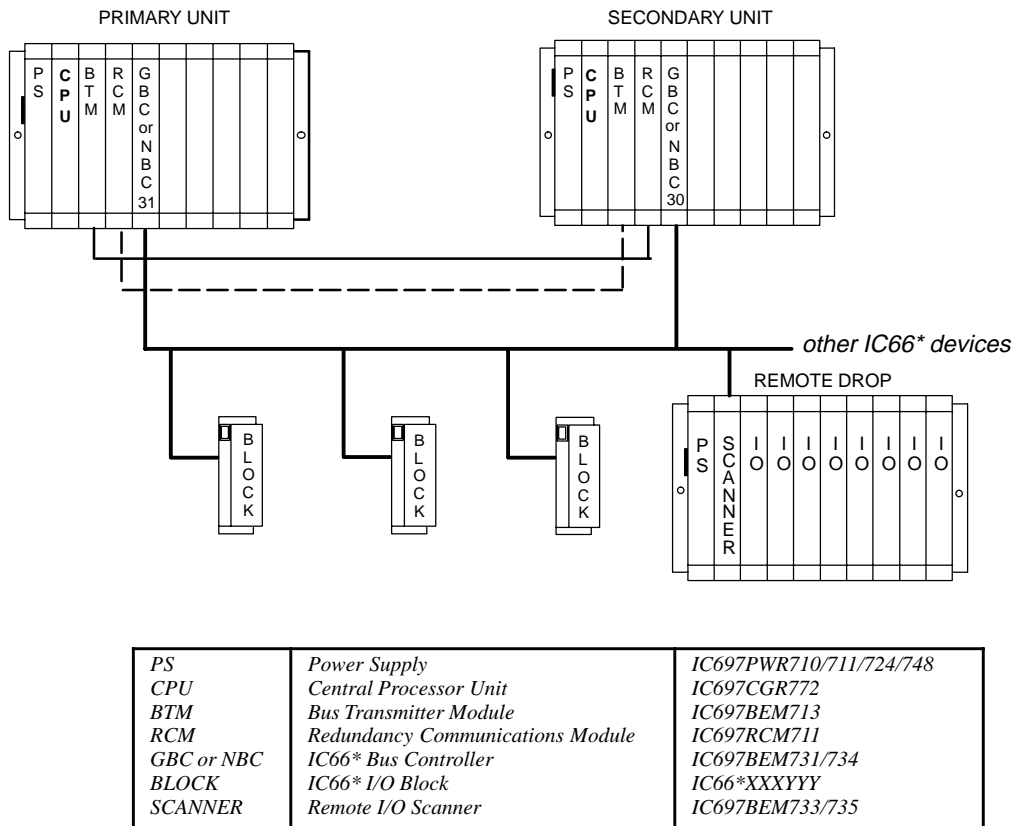

Figure 1. Typical Hot Standby CPU Redundancy System Configuration

User Memory

Program and data memory for the CGR772 is provided by a memory board with 512 KBytes of battery-backed CMOS RAM. This memory board is an integral part of the CGR772 and is included with the module. This memory board provides error checking through a CPU checksum routine with detected parity errors being reported to the CPU as they occur.

Operation, Protection, and Module Status

Operation of this module may be controlled by the three position RUN/STOP switch or remotely by an attached programmer and programming software. Program and configuration data can be locked through software passwords or manually by the memory protect keyswitch. When the key is in the *protected* position, program and configuration data can only be changed by a programmer connected through parallel communications (that is, via the Bus Transmitter module). The status of the CPU is indicated by the seven green LEDs on the front of the module.

**96 MHz, 32-Bit Floating Point, 512 KByte Memory
Central Processing Unit for CPU Redundancy Applications**

November 1999

CPU Redundancy Systems

The CGR772 is used as the controller in a CPU Redundancy system. Two redundancy control methods can be configured using the CGR772. The GHS method (IC660/661 Hot Standby) uses multiple single bus IC660/661I/O networks with one redundant controller in each synchronized PLC. The GDB method (IC660/661Dual Bus) uses multiple dual bus IC660/661 I/O networks with two redundant controllers in each synchronized PLC. The location of the CGR772 modules in a typical Hot Standby CPU Redundancy system is shown in Figure 1.

Installation

It is the responsibility of the OEM, system integrator, or end user to properly install the PLC equipment for safe and reliable operation. Product manuals provide detailed information about installation, startup, and proper use of the PLC equipment. The installation manual, shipped with your PLC programming software, describes how to properly install the equipment. If the PLC installation must comply with supported standards, such as FCC or CE Directives, please refer to the *Installation Requirements for Conformance to Standards*, shipped with the PLC programming software, for additional guidelines.

Installation should not be attempted without referring to the applicable *Programmable Controller Installation Manual* and the *Hot Standby CPU Redundancy Manual*.

- Connect the battery to either of the battery connectors on the module.
- Put toggle switch in the STOP position.
- Put keyswitch in Memory Protection OFF position.
- Make sure rack power is off.
- Install in slot 1 of rack 0. (See Figure 1)
- Turn on power. The module should power up and the top left (OK) LED should blink. When the diagnostics have completed successfully, the top left LED stays on and the second (RUN) and third (EN) LEDs are off. The fourth (bottom left) LED (MEM PROTECT) is off if the keyswitch is in the OFF position. The CPU is now ready to be programmed (if connected parallel, the CPU can be programmed regardless of key position). After the program has been verified the toggle switch can be moved to the appropriate operation mode position; RUN WITH OUTPUTS ENABLED, RUN WITH OUTPUTS DISABLED, or STOP. The LEDs indicate the position of the toggle switch, memory protection status, status of serial port activity, and the state of the program.

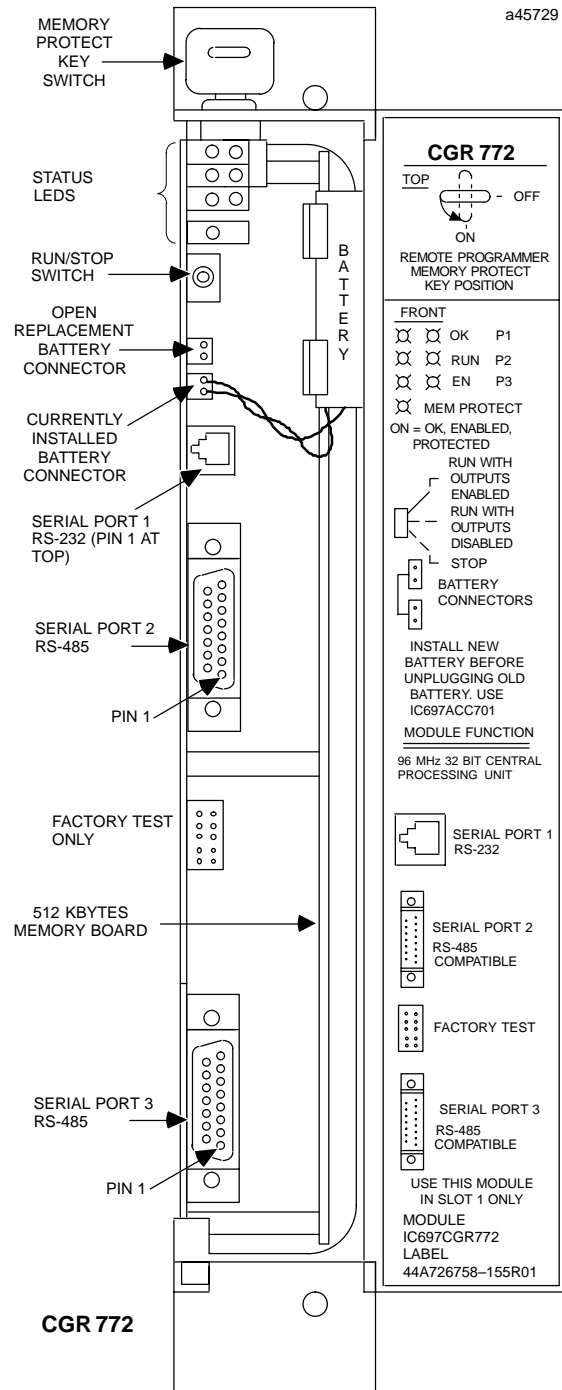

Figure 2. CGR 772 - Location of Major Features

November 1999

96 MHz, 32-Bit Floating Point, 512 KByte Memory Central Processing Unit for CPU Redundancy Applications

Programmer Connection, Parallel Interface

The programmer connects to the top port on the Bus Transmitter Module (IC697BEM713) system interface module for a parallel interface (MS-DOS programmer only) as shown in Figure 1

Connection to Serial Ports

The CGR772 has three on-board serial ports which can be configured to behave as three independent communications ports. These three ports are accessed by connections on the front of the module for serial interface to the programming computer, or other serial devices.

Ports 1 through 3 support SNP Slave protocol only. Ports 1 and 2 do not support program Load and Store or Datagrams. For details, see the Important Product Information sheet that ships with the module.

Protocols Supported

	Port 1	Port 2	Port 3
SNP	Yes	Yes	Yes
SNPX	No	No	No
RTU	Not supported	Not supported	Not supported

The programmer connection (shown below) is typically made from CPU serial Port 3 to the serial port on the programming computer, through an RS-422/RS-485 to RS-232 Converter (IC690ACC900) or RS-422 to RS-232 Miniconverter (IC690ACC901). This connection can be made with available cables or you may build cables to fit the needs of your particular application. See the IC697 *Programmable Controller Serial Communications Manual* for more information on serial communications.

Note

When configuring a CPU Redundancy system the programmer must be connected to the CPU in the Primary unit to configure the Primary PLC and then moved to the CPU in the Secondary PLC to configure the Secondary PLC.

For more detailed information on configuration of Hot Standby CPU Redundancy systems and communications between PLCs in the system, refer to the *Hot Standby CPU Redundancy User's Guide*.

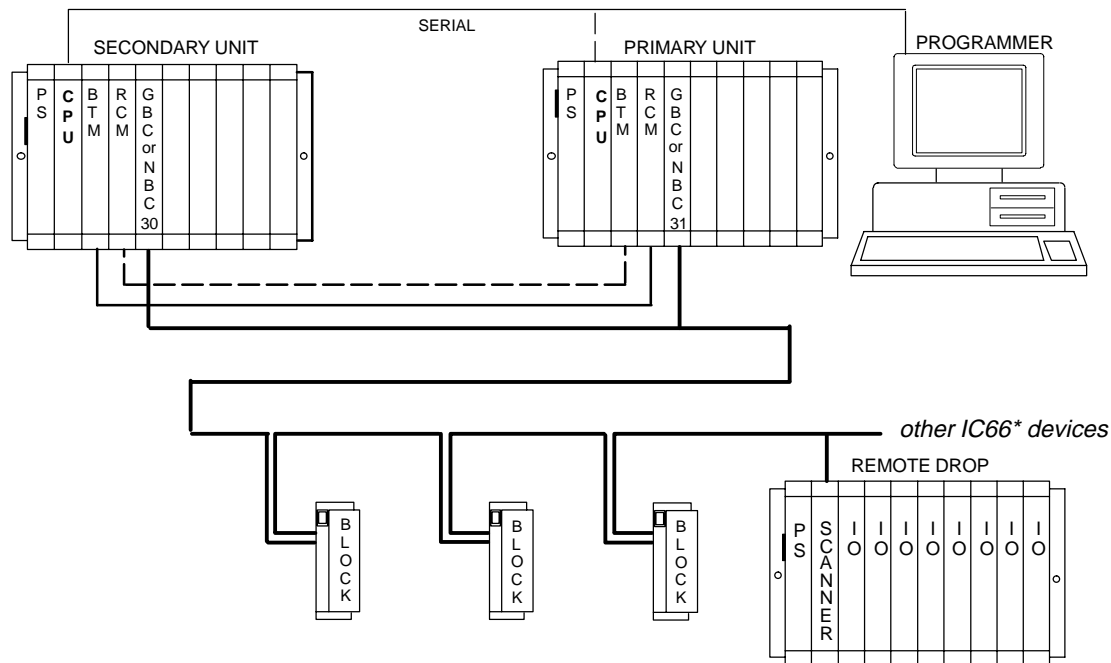

Figure 3. Hot Standby CPU Redundancy System Configuration with Serial Connection to Programmer

**96 MHz, 32-Bit Floating Point, 512 KByte Memory
Central Processing Unit for CPU Redundancy Applications**

November 1999

CPU Serial Ports

Support for Port 1, Port 2, and Port 3 was provided for the CGR772 in its initial release in October 1998 (equipped with firmware release 7.85).

- **Port 1**, the top port, is RS-232 compatible. Port 1 has a 6-pin, female, RJ-11 connector. This connector is similar in appearance (although larger) to modular jacks commonly used for telephones and modems.

Table 10-3. Port 1 RS-232 Signals

Pin Number	Signal Name	Description
1 *	CTS	Clear To Send
2	TXD	Transmit Data
3	0V	Signal Ground
4	0V	Signal Ground
5	RXD	Receive Data
6	RTS	Request to Send

* Pin 1 is at the top of the connector as viewed from the front of the module.

- **Port 2**, the center port, is RS-485 compatible and is optocoupler isolated. Port 2 has a 15-pin, female D-connector.

Table 10-4. Port 2 RS-485 Signals

Pin Number	Signal Name	Description
1*	Shield	Cable Shield
2	NC	No Connection
3	NC	No Connection
4	NC	No Connection
5	+5VDC	Logic Power **
6	RTS(A)	Differential Request to Send
7	SG	Signal Ground
8	CTS(B')	Differential Clear To Send
9	RT	Resistor Termination
10	RD(A)	Differential Receive Data
11	RD(B')	Differential Receive Data
12	SD(A)	Differential Send Data
13	SD(B)	Differential Send Data
14	RTS(B')	Differential Request To Send
15	CTS(A)	Differential Clear To Send

*Pin 1 is at the bottom right of the connector as viewed from the front of the module.

** Note that Pin 5 provides Isolated +5 VDC power (100 mA maximum) for powering external options.

- **Port 3**, the bottom port, is also RS-485 compatible but is not isolated. Port 3 has a 15-pin, female D-connector. Pin assignments are found in the *IC697 PLC Installation Manual*.

Programmer Connection, Ethernet TCP/IP

Connecting your programmer via an Ethernet TCP/IP network requires installation of an Ethernet Interface module in the PLC. This can be either the Ethernet Controller, IC697CMM741, or Ethernet Interface (Type 2), IC697CMM742. Before connecting your programmer and PLC to the Ethernet TCP/IP network you must set the IP address in the Ethernet Interface. After setting the IP address, connect the PLC and the programmer running Windows software to the Ethernet Interface.

For more detailed information on Ethernet TCP/IP, refer to the *TCP/IP Ethernet Communications (Type 2) User's Manual*, and the Windows programming manual, GFK-1295.

Configuration

This CPU and its I/O system are configured with MS-DOS or Windows based programming software. There are no DIP switches or jumpers used to configure the system. The CPU verifies the actual module and rack configuration at power-up and periodically during operation. The actual configuration must be the same as the programmed configuration. Deviations are reported to the CPU alarm processor function for configured fault response. Consult Reference 1 (in Table 2.) for a description of configuration functions.

Batteries

A lithium battery (IC697ACC701) is installed as shown in Figure 2. This battery maintains program and data memory when power is removed and operates the calendar clock. Be sure to install the new battery before removing the old battery. If during power-up diagnostics a low battery is detected, the Module OK LED (top) will not stay on. See the section on System Status References in Chapter 2 of the IC697 PLC Reference Manual for more details about detecting a low battery condition.

November 1999

96 MHz, 32-Bit Floating Point, 512 KByte Memory Central Processing Unit for CPU Redundancy Applications

Operation in High Ambient Temperatures

The CGR772 requires either forced air cooling or limiting of system power for operating in ambient temperatures greater than 50°C (122°F). A fan capable of 70 CFM (including filters) should be located beneath slot 1 of the rack containing the CPU. Fan assemblies (IC697ACC721, IC697ACC724, and IC697ACC744) can be ordered for direct mounting on the IC697 rack. Refer to the *IC697 Programmable Controller Installation Manual* for detailed information.

For continuous operation above 50°C in a minimum size enclosure without forced air cooling, it is necessary to limit system power. De-rating data for the 100W AC/DC Power Supply (PWR711) and the 90W DC Power Supplies (PWR724/PWR748) is shown in the chart below.

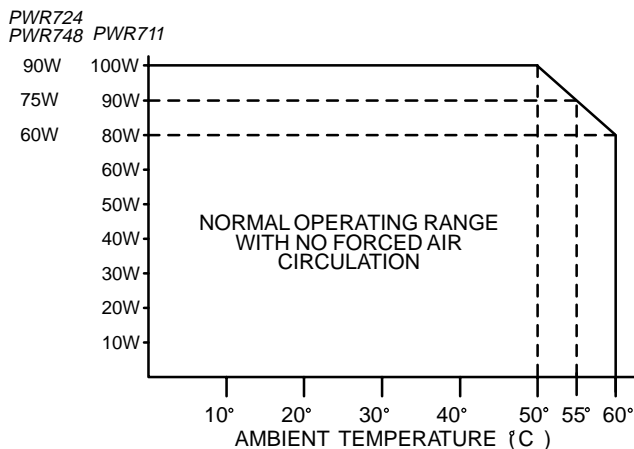

Table 1. Specifications for IC697CGR772 †

Battery	
Shelf life	5 years at 20° C (68° F)
Memory retention	6 months nominal without applied power.
Current required from 5V bus	3.1 Amps nominal
Operating Temperature	0 to 60°C (32°F to 140°F)
Time of Day Clock accuracy	" 3.5 seconds per day maximum
Elapsed Time Clock (internal timing) accuracy	" .01% maximum
Serial Ports	Programmer Serial Attachment, or other serial devices
Port 1: RS-232 compatible	Protocols supported: SNP Slave only
Port 2: RS-485 compatible (optocoupler isolated)	
Port 3: RS-485 compatible (not isolated)	

† Refer to GFK-0867B, or later for product standards and general specifications. For installations requiring compliance to more stringent requirements (for example, FCC or European Union Directives), refer to *Installation Requirements for Conformance to Standards*.

Removing a Module

The following instructions should be followed when removing a CGR772 module from its slot in a rack. If a fault in the CPU hardware is detected that is logged as FATAL, the CPU will go to STOP mode and control will be switched from the active unit (with the failed CPU) to the backup unit. Power can then be removed from the rack containing the failed CPU and the CPU replaced. If a failure is detected in the backup unit, you can simply remove power from the CPU rack and replace the module.

- Grasp the board firmly at the top and bottom of the board cover with your thumbs on the front of the cover and your fingers on the plastic clips on the back of the cover.
- Squeeze the rack clips on the back of the cover with your fingers to disengage the clip from the rack rail and pull the board firmly to remove it from the backplane connector.
- Slide the board along the card guide and remove it from the rack.

**96 MHz, 32-Bit Floating Point, 512 KByte Memory
Central Processing Unit for CPU Redundancy Applications**

November 1999

Table 2. References

Reference	Title
1	Programming Software User's Manual
2	Programmable Controller Reference Manual
3	Programmable Controller Installation Manual
4	Hot Standby CPU Redundancy User's Guide

Table 3. Ordering Information

Description	Catalog Number
Central Processing Unit 96 MHz, 32-Bit, Floating Point, 512 Kbytes CMOS RAM Memory for CPU Redundancy applications	IC697CGR772
Redundancy Communications Module	IC697RCM711
Bus Transmitter Module	IC697BEM713
Lithium Battery	IC697ACC701
Rack Fan Assembly, 120 VAC Rack Fan Assembly, 240 VAC Rack Fan Assembly, 24 VDC	IC697ACC721 IC697ACC724 IC697ACC744

Note: For Conformal Coat option, please consult the factory for price and availability.

GFK-1439C
November 1999

96 MHz, 32-Bit Floating Point, 1 MByte Fast Memory Central Processing Unit for CPU Redundancy Applications

Features

- Required for CPU redundancy applications
- Supports floating point calculation
- Single slot CPU
- 12K inputs and 12K outputs (any mix)
- Up to 8K analog I/O
- 0.4 microseconds per boolean function
- 96MHz, 80486DX4 microprocessor
- Supports IC660/IC661 and IC697I/O products
- Programmed by MS-DOS® or Windows® based software products
- Supports 1 Mbyte of battery-backed fast CMOS RAM memory in the same slot
- Configurable data and program memory
- Battery-backed calendar clock
- Three position operation mode switch
- Password controlled access
- Keyswitch memory protection
- Seven status LEDs
- Software configuration (No DIP switches or jumpers to set)
- Reference information inside front door
- Three Series Ninety Protocol (SNP Slave) communications ports

Redundancy Features

In addition to the above features, the CGR935 supports the redundancy features listed below.

- Bumpless switching between redundancy PLCs
- Synchronization of CPUs
- Redundant backup communications
- 4.7 ms scan extension
- One scan switching (in most cases)
- Configurable backup data size
- On-line programming
- On-line repair
- No single point of failure (except for IC66* I/O Blocks and bus stubs)
- Same or different program in Primary and Secondary PLCs
- Program control switching

- Symptom status bits and fault tables
- Memory parity and checksums
- Common I/O on IC660/IC661 bus
- Manual switching with pushbutton switch on Redundancy Communications Module

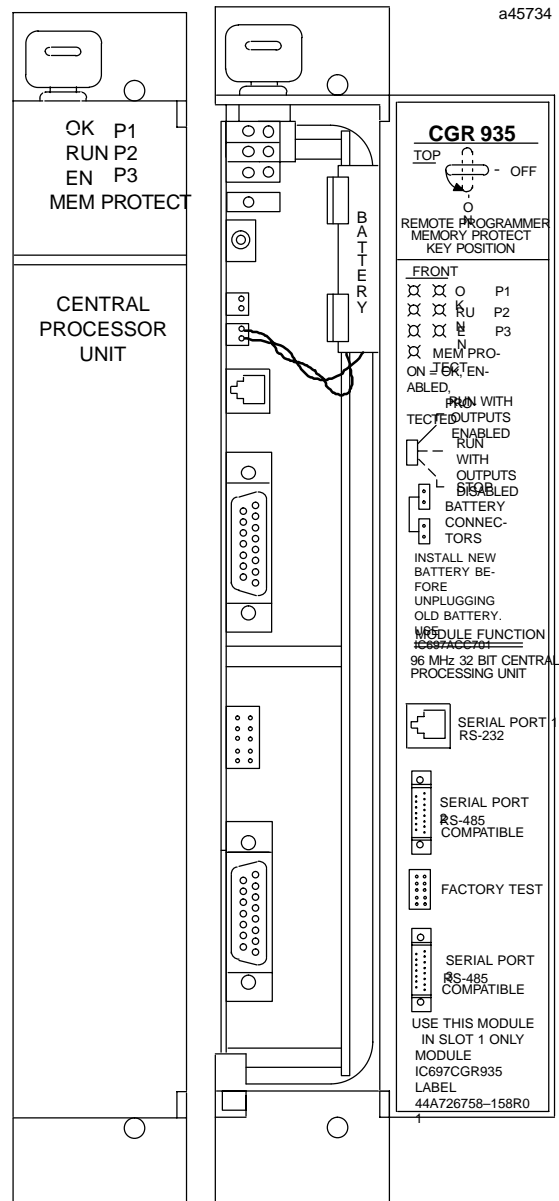

© MS-DOS and Windows are registered trademarks of Microsoft Corporation.

GFK-1439C
November 1999

96 MHz, 32-Bit Floating Point, 1 MByte Fast Memory Central Processing Unit for CPU Redundancy Applications

Functions

The CGR935 is a single slot programmable controller CPU which allows floating point calculations and is required for CPU redundancy applications. The CGR935 is programmed and configured by MS-DOS or Windows programming software to perform real time control of machines, processes and material handling systems.

The CGR935 communicates with I/O and smart option (specialty) modules over the rack mounted backplane (IC697CHS750, 790, 791) by way of the VME C.1 Standard format.

Supported option modules include all IC697 LAN interface modules, several Coprocessor modules, Bus Controller for IC660/IC661 I/O, Communications modules, and all of the IC697 family of discrete and analog I/O modules.

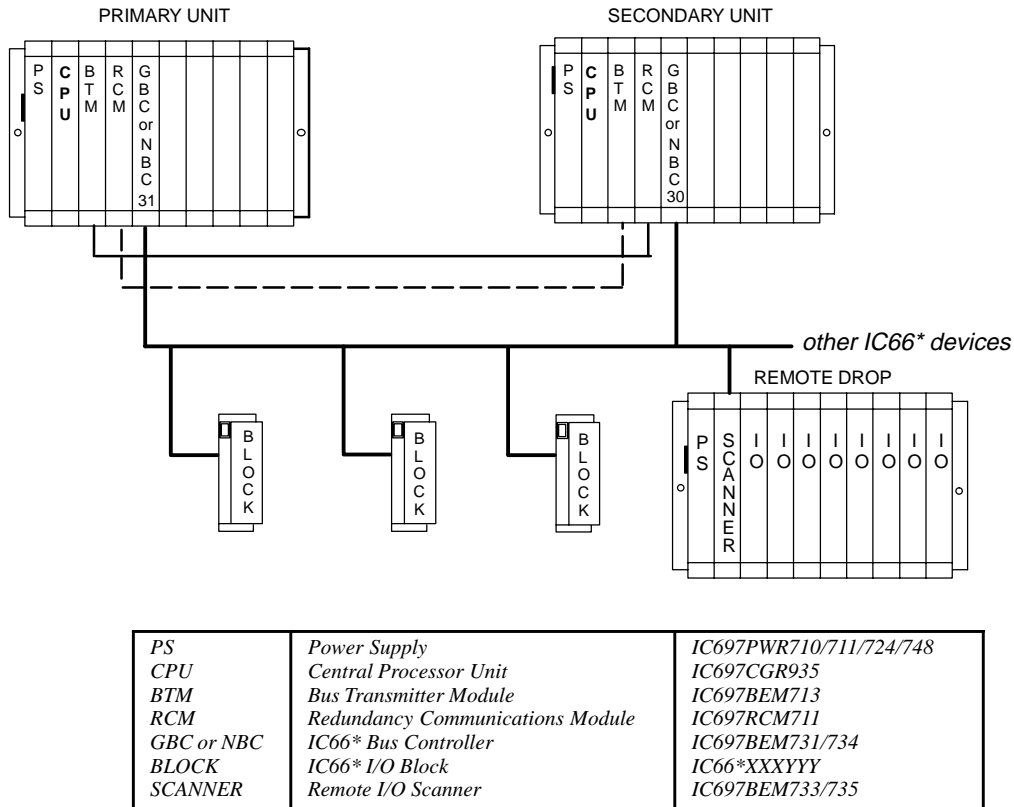

Figure 1. Typical Hot Standby CPU Redundancy System Configuration

User Memory

Program and data memory for the CGR935 is provided by a memory board with 1 MByte of battery-backed Fast CMOS RAM. This memory board is an integral part of the CGR935 and is included with the module. This memory board provides error checking through a CPU checksum routine with detected parity errors being reported to the CPU as they occur. Starting with firmware release 7.85 (October, 1998), increased program memory size was made available. See the *Important Product Information (IPI)* sheet, GFK-1440, that ships with the module for details.

Operation, Protection, and Module Status

Operation of this module may be controlled by the three position RUN/STOP switch or remotely by an attached programmer and programming software. Program and configuration data can be locked through software passwords or manually by the memory protect keyswitch. When the key is in the *protected* position, program and configuration data can only be changed by a programmer connected through parallel communications (that is, via the Bus Transmitter module). The status of the CPU is indicated by the seven green LEDs on the front of the module.

**96 MHz, 32-Bit Floating Point, 1 MByte Fast Memory
Central Processing Unit for CPU Redundancy Applications**

GFK-1439C
November 1999

CPU Redundancy Systems

The CGR935 is used as the controller in a CPU Redundancy system. Two redundancy control methods can be configured using the CGR 935. The GHS method (IC660/661 Hot Standby) uses multiple single bus IC660/661 I/O networks with one redundant controller in each synchronized PLC. The GDB method uses multiple I/O networks with either single or dual busses in each synchronized PLC with the capability of either unit being activated with bumpless switch. The location of the CGR935 modules in a typical Hot Standby CPU Redundancy system is shown in Figure 1.

Installation

It is the responsibility of the OEM, system integrator, or end user to properly install the PLC equipment for safe and reliable operation. Product manuals provide detailed information about installation, startup, and proper use of the PLC equipment. The installation manual, shipped with your PLC programming software, describes how to properly install the equipment. If the PLC installation must comply with supported standards, such as FCC or CE Directives, please refer to the *Installation Requirements for Conformance to Standards*, shipped with the PLC programming software, for additional guidelines.

Do not attempt installation without referring to the applicable *Programmable Controller Installation Manual* and the *Hot Standby CPU Redundancy Manual*.

- Connect the battery to either of the battery connectors on the module.
- Put keyswitch in Memory Protect OFF position.
- Make sure rack power is off.
- Install in slot 1 of rack 0. (See Figure 1)
- Turn on power. The module should power up and the top left (OK) LED should blink. When the diagnostics have completed successfully, the top left LED stays on and the second (RUN) and third (EN) LEDs are off. The fourth (bottom left) LED (MEM PROTECT) is off if the keyswitch is in the OFF position. The CPU is now ready to be programmed (if connected parallel, the CPU can be programmed regardless of key position). After the program has been verified, the toggle switch can be moved to the appropriate operation mode position; RUN WITH OUTPUTS ENABLED, RUN WITH OUTPUTS DISABLED, or STOP. The LEDs indicate the position of

the toggle switch, memory protection status, status of serial port activity, and the state of the program.

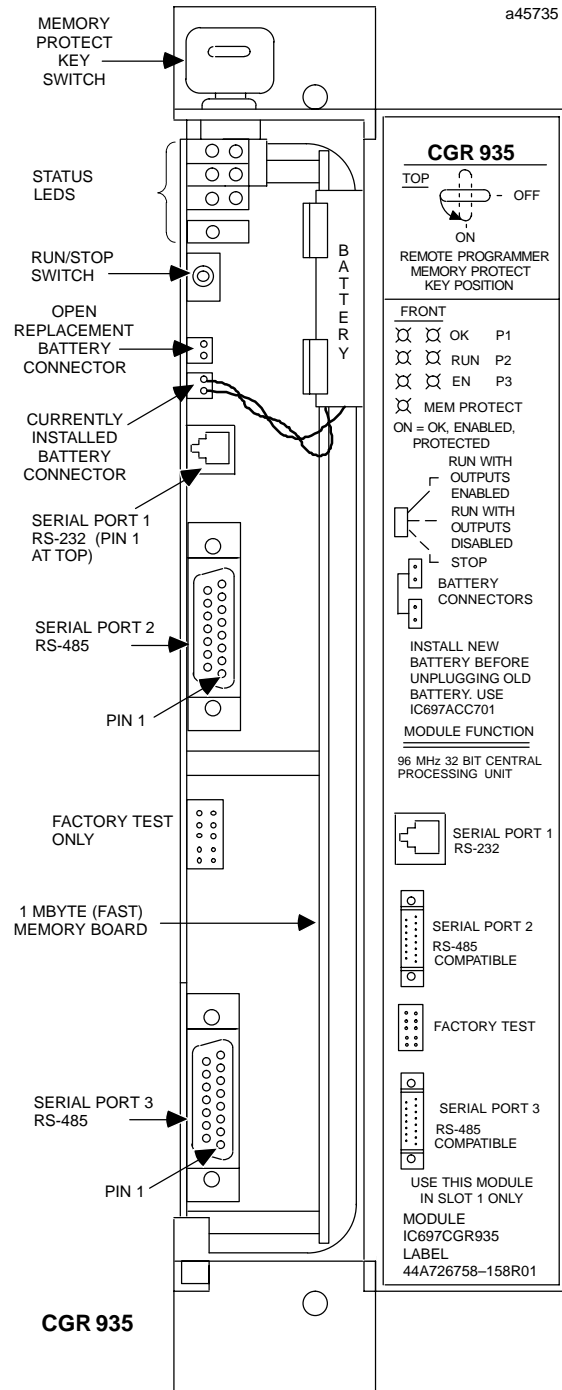

Figure 2. CGR 935 - Location of Major Features

GFK-1439C
November 1999

96 MHz, 32-Bit Floating Point, 1 MByte Fast Memory Central Processing Unit for CPU Redundancy Applications

Programmer Connection, Parallel Interface

The programmer connects to the top port on the Bus Transmitter Module (IC697BEM713) for a parallel interface (MS-DOS programmer only) as shown in Figure 1.

Connection to Serial Ports

The CGR935 has three on-board serial ports which can be configured to behave as three independent communications ports. These three ports are accessed by connections on the front of the module for serial interface to the programming computer, or other serial devices.

Ports 1 through 3 support SNP Slave protocol only. Ports 1 and 2 do not support program Load and Store or Datagrams. For details, see the Important Product Information sheet that ships with the module.

Protocols Supported

	Port 1	Port 2	Port 3
SNP	Yes	Yes	Yes
SNPX	No	No	No
RTU	Not supported	Not supported	Not supported

The programmer connection (shown below) is typically made from CPU serial Port 3 to the serial port on the programming computer, through an RS-422/RS-485 to RS-232 Converter (IC690ACC900) or RS-422 to RS-232 Miniconverter (IC690ACC901). This connection can be made with available cables or you may build cables to fit the needs of your particular application. See the IC697 Programmable Controller Serial Communications Manual for more information on serial communications.

Note

When configuring a CPU Redundancy system, the programmer must be connected to the CPU in the Primary unit to configure the Primary PLC and then moved to the CPU in the Secondary PLC to configure the Secondary PLC.

For more detailed information on configuration of Hot Standby CPU Redundancy systems and communications between PLCs in the system, refer to the *Hot Standby CPU Redundancy User's Guide*.

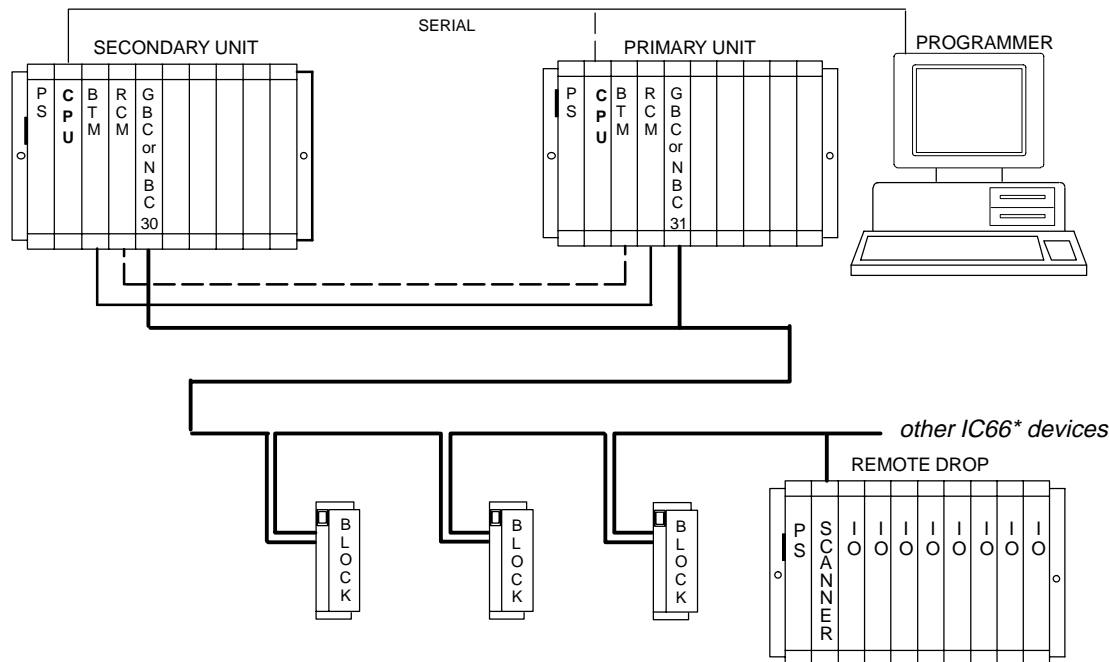

Figure 3. Hot Standby CPU Redundancy System Configuration with Serial Connection to Programmer

**96 MHz, 32-Bit Floating Point, 1 MByte Fast Memory
Central Processing Unit for CPU Redundancy Applications**

GFK-1439C
November 1999

CPU Serial Ports

Support for Port 1 and Port 2 was added in firmware release 7.85 (October, 1998). Prior releases only supported Port 3.

- **Port 1**, the top port, is RS-232 compatible. Port 1 has a 6-pin, female, RJ-11 connector. This connector is similar in appearance (although larger) to modular jacks commonly used for telephones and modems.

Table 10-5. Port 1 RS-232 Signals

Pin Number	Signal Name	Description
1 *	CTS	Clear To Send
2	TXD	Transmit Data
3	0V	Signal Ground
4	0V	Signal Ground
5	RXD	Receive Data
6	RTS	Request to Send

* Pin 1 is at the top of the connector as viewed from the front of the module.

- **Port 2**, the center port, is RS-485 compatible and is optocoupler isolated. Port 2 has a 15-pin, female D-connector.

Table 10-6. Port 2 RS-485 Signals

Pin Number	Signal Name	Description
1*	Shield	Cable Shield
2	NC	No Connection
3	NC	No Connection
4	NC	No Connection
5	+5VDC	Logic Power **
6	RTS(A)	Differential Request to Send
7	SG	Signal Ground
8	CTS(B')	Differential Clear To Send
9	RT	Resistor Termination
10	RD(A)	Differential Receive Data
11	RD(B')	Differential Receive Data
12	SD(A)	Differential Send Data
13	SD(B)	Differential Send Data
14	RTS(B')	Differential Request To Send
15	CTS(A)	Differential Clear To Send

*Pin 1 is at the bottom right of the connector as viewed from the front of the module.

** Note that Pin 5 provides Isolated +5 VDC power (100 mA maximum) for powering external options.

- **Port 3**, the bottom port, is also RS-485 compatible but is not isolated. Port 3 has a 15-pin, female D-connector. Pin assignments are found in the *IC697 PLC Installation Manual*.

Programmer Connection, Ethernet TCP/IP

Connecting your programmer via an Ethernet TCP/IP network requires installation of an Ethernet Interface module in the PLC. This can be either the Ethernet Controller, IC697CMM741, or Ethernet Interface (Type 2), IC697CMM742. Before connecting your programmer and PLC to the Ethernet TCP/IP network you must set the IP address in the Ethernet Interface. After setting the IP address, connect the PLC and the programmer running Windows software to the Ethernet Interface.

For more detailed information on Ethernet TCP/IP, refer to the *TCP/IP Ethernet Communications (Type 2) User's Manual*, and the Windows programming manual, GFK-1295.

Configuration

The IC697 CPU and I/O system is configured with MS-DOS or Windows based programming software. There are no DIP switches or jumpers used to configure the system. The CPU verifies the actual module and rack configuration at power-up and periodically during operation. The actual configuration must be the same as the programmed configuration. Deviations are reported to the CPU alarm processor function for configured fault response. Consult Reference 1 (Table 2.) for a description of configuration functions.

Batteries

A lithium battery (IC697ACC701) is installed as shown in Figure 2. This battery maintains program and data memory when power is removed and operates the calendar clock. Be sure to install the new battery before removing the old battery. If during power-up diagnostics a low battery is detected the Module OK LED (top) will not stay on. See the section "System Status References" in Chapter 2 of the IC697 PLC Reference Manual for more details about detecting a low battery condition.

GFK-1439C
November 1999

96 MHz, 32-Bit Floating Point, 1 MByte Fast Memory Central Processing Unit for CPU Redundancy Applications

Operation in High Ambient Temperatures

The CGR935 requires either forced air cooling or limiting of system power for operating in ambient temperatures greater than 50°C (122°F). A fan capable of 70 CFM (including filters) should be located beneath slot 1 of the rack containing the CPU.

Fan assemblies (IC697ACC721, IC697ACC724, and IC697ACC744) can be ordered for direct mounting on the IC697 rack. Refer to the IC697 *Programmable Controller Installation Manual* for detailed information.

For continuous operation above 50°C in a minimum size enclosure without forced air cooling, it is necessary to limit system power. De-rating data for the 100W AC/DC Power Supply (PWR711), and the 90W DC Power Supplies (PWR724/PWR748) is shown in the chart below.

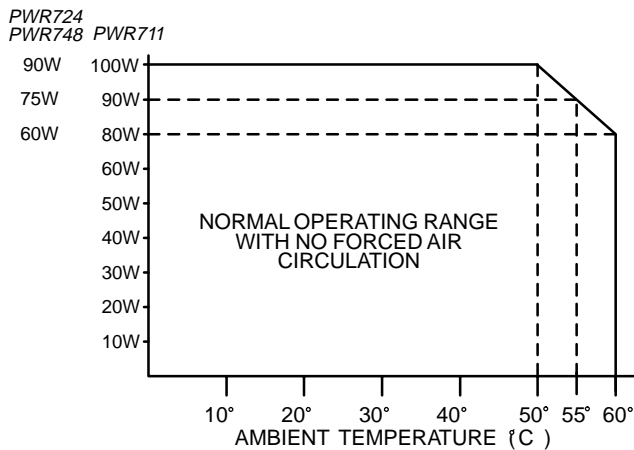

Table 1. Specifications for IC697CGR935 †

Battery	
Shelf life	5 years at 20° C (68° F)
Memory retention	6 months nominal without applied power.
Current required from 5V bus	3.1 Amps nominal
Operating Temperature	0 to 60°C (32°F to 140°F); 70 CFM forced air required 0 to 50°C (32°F to 122°F); without forced air
Time of Day Clock accuracy	" 3.5 seconds per day maximum
Elapsed Time Clock (internal timing) accuracy	" .01% maximum
Serial Ports	Programmer Serial Attachment, or other serial devices.
Port 1: RS-232 compatible	
Port 2: RS-485 compatible (optocoupler isolated)	Protocols supported: SNP Slave only
Port 3: RS-485 compatible (not isolated)	

† Refer to GFK-0867B, or later for product standards and general specifications. For installations requiring compliance to more stringent requirements (for example, FCC or European Union Directives), refer to *Installation Requirements for Conformance to Standards*.

Removing a Module

The following instructions should be followed when removing a CGR935 module from its slot in a rack. If a fault in the CPU hardware is detected that is logged as FATAL, the CPU will go to STOP mode and control will be switched from the active unit (with the failed CPU) to the backup unit. Power can then be removed from the rack containing the failed CPU and the CPU replaced. If a failure is detected in the backup unit, you can simply remove power from the CPU rack and replace the module.

- Grasp the board firmly at the top and bottom of the board cover with your thumbs on the front of the cover and your fingers on the plastic clips on the back of the cover.
- Squeeze the rack clips on the back of the cover with your fingers to disengage the clip from the rack rail and pull the board firmly to remove it from the backplane connector.
- Slide the board along the card guide and remove it from the rack.

**96 MHz, 32-Bit Floating Point, 1 MByte Fast Memory
Central Processing Unit for CPU Redundancy Applications**

GFK-1439C
November 1999

Table 2. References

Reference	Title
1	Programming Software User's Manual
2	Programmable Controller Reference Manual
3	Programmable Controller Installation Manual
4	Hot Standby CPU Redundancy User's Guide

Table 3. Ordering Information

Description	Catalog Number
Central Processing Unit 96 MHz, 32-Bit, Floating Point, 1 Mbyte Fast CMOS RAM Memory for CPU Redundancy applications	IC697CGR935
Redundancy Communications Module	IC697RCM711
Bus Transmitter Module	IC697BEM713
Lithium Battery	IC697ACC701
Rack Fan Assembly, 120 VAC Rack Fan Assembly, 240 VAC Rack Fan Assembly, 24 VDC	IC697ACC721 IC697ACC724 IC697ACC744

Note: For Conformal Coat option, please consult the factory for price and availability.

GFK-0806D
August 1997

16 MHz, 32-Bit Expandable Central Processing Unit for IC66* Triple Modular Redundancy Systems

Features

- Single slot CPU.
- Supports 512 Kbytes of battery-backed expansion memory in the same slot. (Up to approximately 200 Kbytes available for user's application program and data).
- Up to 352 discrete inputs and outputs (any mix, simplex mode only); 112 voted discrete inputs, 80 voted discrete outputs.
Up to 8K analog inputs (simplex mode only) and 8K analog outputs (simplex mode only); 1024 voted analog inputs
- 0.4 microseconds per boolean function.
- 16 MHz, 80386DX microprocessor.
- Supports IC660/IC661 I/O (and IC697 I/O in simplex mode only)
- Programmed by MS-DOS®, or Windows® software products running on Windows® 95 or Windows NT® over Ethernet TCP/IP or through the SNP port.
- Configurable data and program memory.
- Battery-backed calendar clock.
- Three position operation mode switch.
- Password controlled access.
- Remote programmer keyswitch memory protection.
- Four status LEDs.
- Software configuration (No DIP switches or jumpers).
- Reference information inside front door.

Functions

The CPU 788 is a single slot programmable controller CPU which is programmed and configured by MS-DOS or Windows based programming software for use in Emergency Shut-Down (ESD), fire and gas, and other critical control applications. It communicates with I/O and smart option modules over the rack mounted back-plane (IC697CHS750, 782, 783, 790, 791) by way of the VME C.1 Standard format.

The CPU 788 must be used in conjunction with a set of C program blocks which provide Triple Modular Redundancy (TMR) operating and autotest routines. It will not operate unless these program blocks are included in the loaded application program.

For detailed information on TMR systems, see Reference 4, the *IC660/661 Modular Redundancy Flexible Triple Modular Redundant (TMR) System User's Manual*.

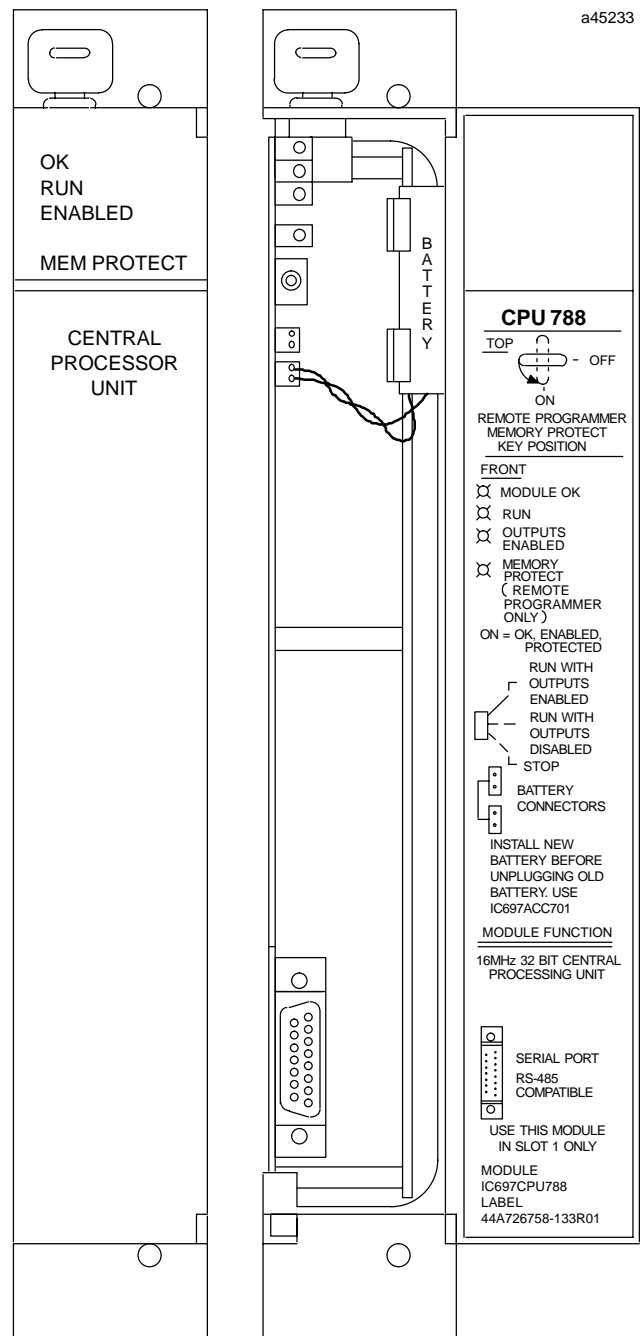

© MS-DOS, Windows, Windows 95, and Windows NT are registered trademarks of Microsoft Corporation.

GFK-0806D
August 1997

16 MHz, 32-Bit Expandable Central Processing Unit for IC66* Triple Modular Redundancy Systems

Supported option modules include IC697 LAN Interface modules, Programmable Coprocessor, Alphanumeric Display Coprocessor, Bus Controller for IC660/IC661

I/O products, Communications modules, I/O Link Interface, and all of the IC697 family of discrete and analog I/O modules.

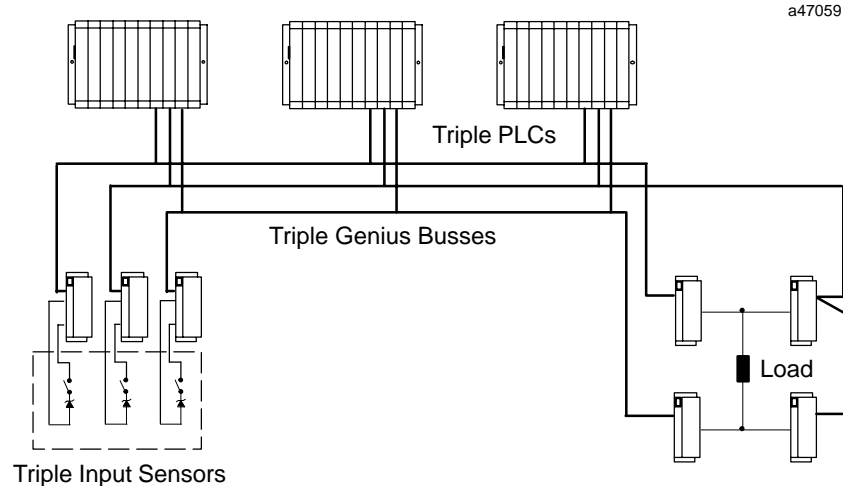

Figure 1. Typical GMR System Configuration

User Memory

Program and data memory for the CPU 788 is available by attaching an expansion memory board with 512 Kbytes battery-backed CMOS RAM. Up to approximately 200 Kbytes of this memory is available for the user application program and data.

Operation, Protection, and Module Status

Operation of this module may be controlled by the three-position RUN/STOP switch or remotely by an attached programmer and programming software. Program and configuration data can be locked through software passwords or manually by the memory protect keyswitch. When the key is in the *protected* position, program and configuration data can only be changed by a programmer connected parallel only (i.e., via the Bus Transmitter module). The status of a CPU is indicated by the four green LEDs on the front of the module.

Installation

It is the responsibility of the OEM, system integrator, or end user to properly install the PLC equipment for safe and reliable operation. Product manuals provide detailed information about installation, startup, and proper use of the PLC equipment. The installation

manual, shipped with your PLC programming software, describes how to properly install the equipment. If the PLC installation must comply with supported standards, such as FCC or CE Directives, please refer to the *Installation Requirements for Conformance to Standards*, shipped with the PLC programming software, for additional guidelines.

- Installation should not be attempted without referring to the applicable programmable controller hardware installation manual.
- Align the expansion memory and CPU connectors.
- Align the captive screws on the memory board with the standoffs already installed on the CPU.
- Push the memory board onto the CPU connector ensuring the mating screws remain aligned with their respective standoff.
- Screw each memory board screw into the standoffs with a #1 Phillips screwdriver, firmly tighten each.
- Connect the battery to either of the battery connectors on the module.
- Put toggle switch in the STOP position.
- Put keyswitch in Memory Protection OFF position.
- Make sure rack power is off.
- Install in slot 1 of rack 0.
- Turn on power.

16 MHz, 32-Bit Expandable Central Processing Unit for IC66* Triple Modular Redundancy Systems

GFK-0806D
August 1997

The module should power up and blink the top LED. When the diagnostics have completed successfully, the top LED stays on and the second and third LEDs are off. The fourth LED is off if the keyswitch is in the OFF position. The CPU is now ready to be programmed (if connected parallel, the CPU can be programmed regardless of key position). After the program has been verified the toggle switch may be moved to the appropriate operation mode position. The LEDs indicate the position of the toggle switch, memory protection status, and the state of the program.

Expansion Memory

The CPU 788 must have a CMOS RAM expansion memory board. The CMOS expansion memory board provides CMOS RAM memory of 512 Kbytes. Up to approximately 200 Kbytes of this memory is available for the user application program and data. The battery which supports this memory is located on the main CPU board housing.

Installation of a CMOS expansion memory board on the CPU will require initialization of the CPU with the programmer (See Reference 2).

Programmer Connection, Parallel

For a parallel interface (MS-DOS programmer only) the programmer is connected to the top port on the Bus Transmitter Module (IC697BEM713). Consult Reference 1 for a description of programming functions.

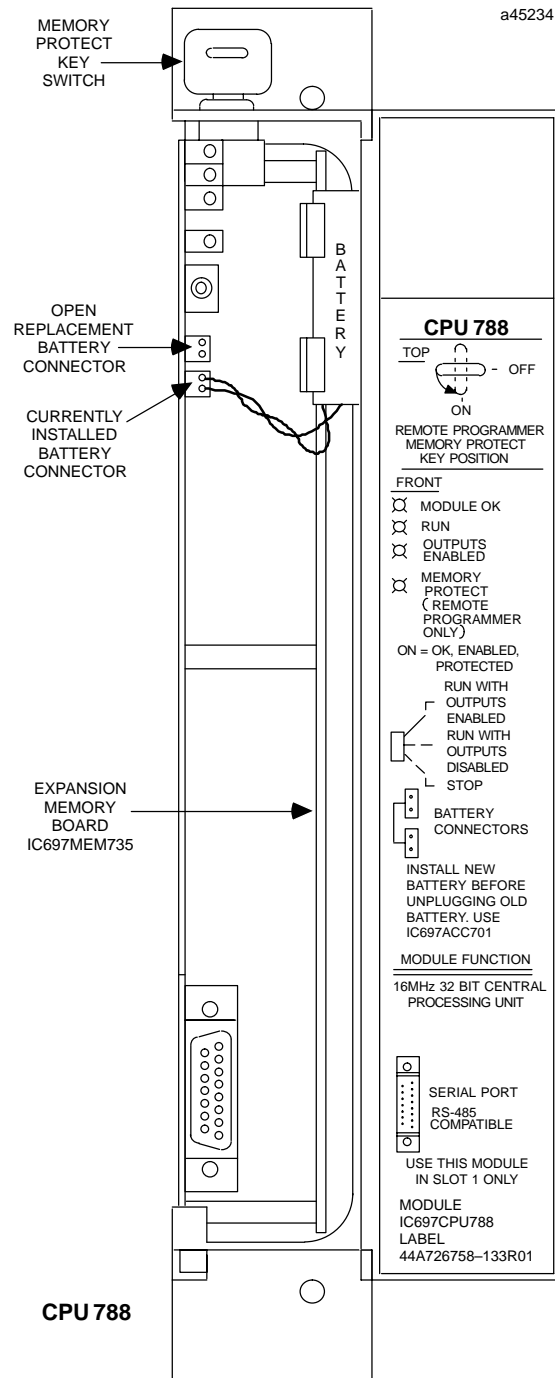

Figure 2. CPU 788 - Location of Major Features

GFK-0806D
August 1997

16 MHz, 32-Bit Expandable Central Processing Unit for IC66* Triple Modular Redundancy Systems

a47100

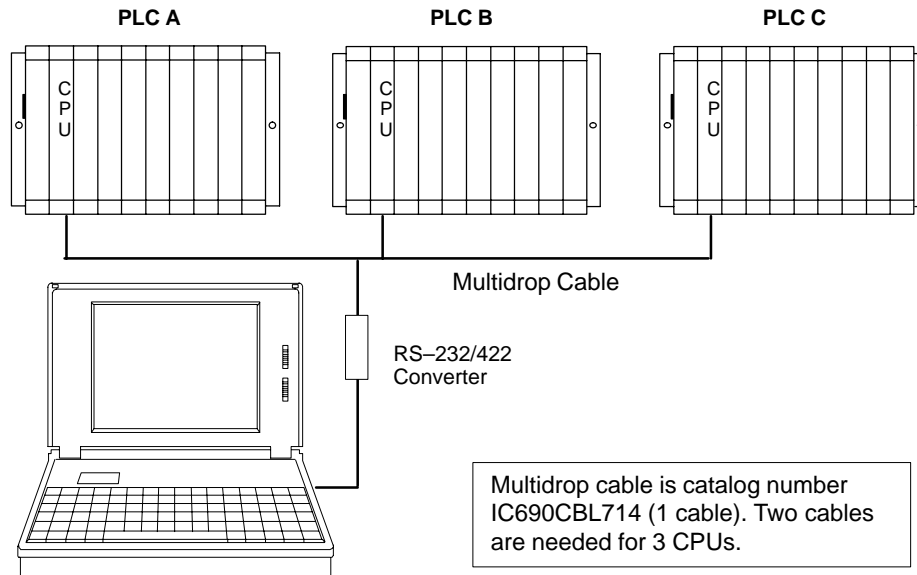

Figure 3. System Configuration, Serial Connection to Programmer

Serial Port

The 15-pin D-connector provides the connection to an RS-485 compatible serial port on the CPU as shown in Figure 3. This port provides a serial connection to a Work Station Interface board installed in the programming computer.

The serial connection can also be made from the serial port on the CPU to the serial port on the programming computer, or other serial device, through the RS-422/RS-485 to RS-232 Converter (IC690ACC900) or RS-232 to RS-422 Miniconverter (IC690ACC901). This connection can be made with available cables or you may build cables to fit the needs of your particular application. For more information on serial communications, see reference 3.

For more detailed information on configuration of TMR systems and communications between PLCs in

the system, refer to the *Modular Redundancy Flexible Triple Modular Redundant (TMR) System User's Manual*.

Programmer Connection, Ethernet TCP/IP

Connecting your programmer via an Ethernet TCP/IP network requires installation of an Ethernet Interface module in the PLC. This can be either the Ethernet Controller, IC697CMM741, or Ethernet Interface (Type 2), IC697CMM742. Before connecting your programmer and PLC to the Ethernet TCP/IP network you must set the IP address in the Ethernet Interface. After setting the IP address, connect the PLC and the programmer running Windows software to the Ethernet Interface.

For more detailed information on Ethernet TCP/IP, refer to the *TCP/IP Ethernet Communications (Type 2) User's Manual*, and the Windows programming manual, GFK-1295.

16 MHz, 32-Bit Expandable Central Processing Unit for IC66* Triple Modular Redundancy Systems

GFK-0806D
August 1997

Configuration

The IC697 CPU and I/O system is configured with MS-DOS or Windows based programming software. There are no DIP switches or jumpers used to configure the system. The CPU verifies the actual module and rack configuration at power-up and periodically during operation. The actual configuration must be the same as the programmed configuration. Deviations are reported to the CPU alarm processor function for configured fault response. Consult Reference 1 for a description of configuration functions.

Battery

A lithium battery (IC697ACC701) is installed as shown in Figure 2. This battery maintains program and data memory when power is removed and operates the calendar clock. Be sure to install the new battery before removing the old battery. If during power-up diagnostics a low battery is detected the Module OK LED (top) will not stay on. Specific indication of a low battery state is detailed in Reference 2.

Removing a Module

The instructions below should be followed when removing a module from its slot in a rack.

- Grasp the board firmly at the top and bottom of the board cover with your thumbs on the front of the cover and your fingers on the plastic clips on the back of the cover.
- Squeeze the rack clips on the back of the cover with your fingers to disengage the clip from the rack rail and pull the board firmly to remove it from the backplane connector.
- Slide the board along the card guide and remove it from the rack.

Table 1. References

Reference	Title
1	Programming Software User's Manual
2	Programmable Controller Reference Manual
3	Programmable Controller Installation Manual
4	IC660/IC661 Modular Redundancy Flexible Triple Modular Redundant (TMR) System User's Manual

GFK-0806D
August 1997

**16 MHz, 32-Bit Expandable Central Processing Unit
for IC66* Triple Modular Redundancy Systems**

Table 2. Specifications for IC697CPU788 †

Battery	
Shelf life	10 years at 20° C (68° F)
Memory retention	6 months nominal without applied power.
Current required from 5V bus	1.6 Amps (includes expansion memory board)
Time of Day Clock accuracy	" 3.5 seconds per day maximum
Elapsed Time Clock (internal timing) accuracy	" .01% maximum
Serial Port	
RS422/485 compatible	Programmer Serial Attachment
VME	System designed to support the VME standard C.1

† Refer to GFK-0867B, or later for product standards and general specifications.

Table 3. Ordering Information

Description	Catalog Number
Central Processor Unit, CPU 788 16 MHz, 32 Bit, Expandable for IC660/IC661 Triple Modular Redundancy Systems	IC697CPU788
512 Kbyte, 32-Bit CMOS Expansion Memory	IC697MEM735
Lithium Battery	IC697ACC701

Note: For Conformal Coat option, or Low Temperature Testing option please consult the factory for price and availability.

GFK-0807D
August 1997

16 MHz, 32-Bit Expandable Central Processing Unit for IC66* Triple Modular Redundancy Systems

Features

- Single slot CPU.
- Supports 512 Kbytes of battery-backed expansion memory in the same slot. (Up to approximately 200 Kbytes available for user's application program and data)
- Up to 12K discrete inputs and outputs (any mix, simplex mode only); 2048 voted discrete inputs, 2048 voted discrete outputs
Up to 8K analog inputs (simplex mode only) and 8K analog outputs (simplex mode only); 1024 voted analog inputs
- 0.4 microseconds per boolean function
- 16 MHz, 80386DX microprocessor
- Supports IC660/IC661 I/O (and IC697 I/O in simplex mode only)
- Programmed by MS-DOS®, or Windows® software products running on Windows® 95 or Windows NT® over Ethernet TCP/IP or through the SNP port
- Configurable data and program memory
- Battery-backed calendar clock
- Three position operation mode switch
- Password controlled access
- Remote programmer keyswitch memory protection
- Four status LEDs
- Software configuration (No DIP switches or jumpers)
- Reference information inside front door.

Functions

The CPU 789 is a single slot programmable controller CPU which is programmed and configured by MS-DOS or Windows based programming software for use in Emergency Shut-Down (ESD), fire and gas, and other critical control applications. It communicates with I/O and smart option modules over the rack mounted back-plane (IC697CHS750, 782, 783, 790, 791) by way of the VME C.1 Standard format.

The CPU 789 must be used in conjunction with a set of C program blocks which provide Triple Modular Redundancy (TMR) operating and autotest routines. It will not operate unless these program blocks are included in the loaded application program.

For detailed information on TMR systems, see Reference 4, the IC660/661 *Modular Redundancy Flexible Triple Modular Redundant (TMR) System User's Manual*.

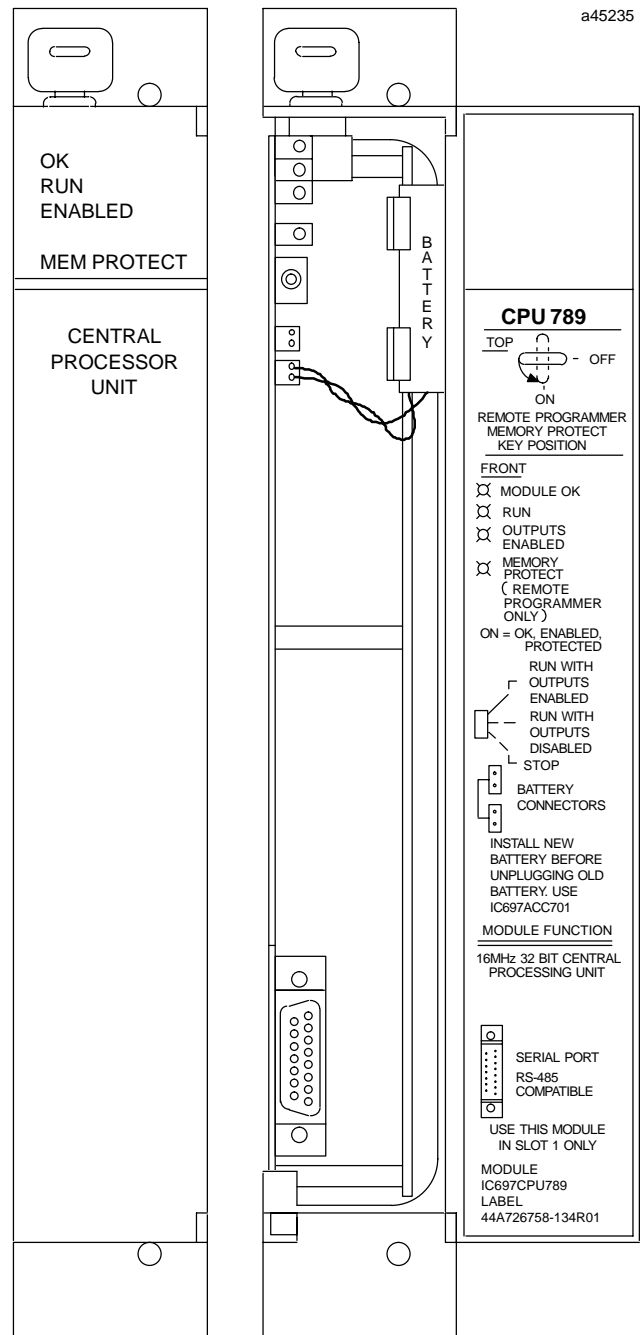

© MS-DOS, Windows, Windows 95, and Windows NT are registered trademarks of Microsoft Corporation.

GFK-0807D
August 1997

16 MHz, 32-Bit Expandable Central Processing Unit for IC66* Triple Modular Redundancy Systems

Supported option modules include IC697 LAN Interface modules, Programmable Coprocessor, Alphanumeric Display Coprocessor, Bus Controller for IC660/IC661 I/O

products, Communications modules, IO Link Interface, and all of the IC697 family of discrete and analog I/O modules.

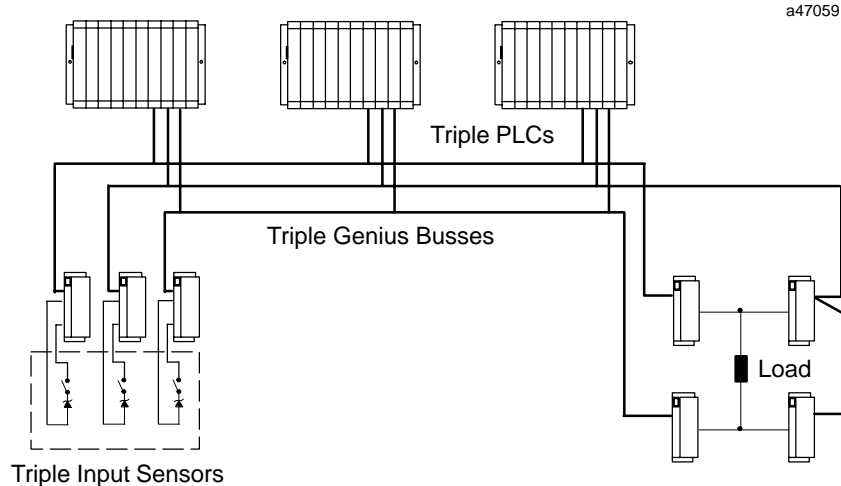

Figure 1. Typical GMR System Configuration

User Memory

Program and data memory for the CPU 789 is available by attaching an expansion memory board with 512 Kbytes battery-backed CMOS RAM. Up to approximately 200 Kbytes of this memory is available for the user application program and data.

Operation, Protection, and Module Status

Operation of this module may be controlled by the three-position RUN/STOP switch or remotely by an attached programmer and IC641 software. Program and configuration data can be locked through software passwords or manually by the memory protect keyswitch. When the key is in the *protected* position, program and configuration data can only be changed by a programmer connected parallel only (that is, via the Bus Transmitter module). The status of a CPU is indicated by the four green LEDs on the front of the module.

Installation

It is the responsibility of the OEM, system integrator, or end user to properly install the PLC equipment for safe and reliable operation. Product manuals provide detailed information about installation, startup, and proper use of the PLC equipment. The installation

manual, shipped with your PLC programming software, describes how to properly install the equipment. If the PLC installation must comply with supported standards, such as FCC or CE Directives, please refer to the *Installation Requirements for Conformance to Standards*, shipped with the PLC programming software, for additional guidelines.

- Installation should not be attempted without referring to the applicable programmable controller hardware installation manual.
- Align the expansion memory and CPU connectors.
- Align the captive screws on the memory board with the standoffs already installed on the CPU.
- Push the memory board onto the CPU connector ensuring the mating screws remain aligned with their respective standoff.
- Screw each memory board screw into the standoffs with a #1 Phillips screwdriver; firmly tighten each.
- Connect the battery to either of the battery connectors on the module.
- Put toggle switch in the STOP position.
- Put keyswitch in Memory Protection OFF position.
- Make sure rack power is off.
- Install in slot 1 of rack 0.
- Turn on power.

16 MHz, 32-Bit Expandable Central Processing Unit for IC66* Triple Modular Redundancy Systems

GFK-0807D
August 1997

The module should power up and blink the top LED. When the diagnostics have completed successfully, the top LED stays on and the second and third LEDs are off. The fourth LED is off if the keyswitch is in the OFF position. The CPU is now ready to be programmed (if connected parallel, the CPU can be programmed regardless of key position). After the program has been verified the toggle switch may be moved to the appropriate operation mode position. The LEDs indicate the position of the toggle switch, memory protection status, and the state of the program.

Expansion Memory

The CPU 789 must have a CMOS RAM expansion memory board. The CMOS expansion memory board provides CMOS RAM memory of 512 Kbytes. Up to approximately 200 Kbytes of this memory is available for the user application program and data. The battery which supports this memory is located on the main CPU board housing.

Installation of a CMOS expansion memory board on the CPU will require initialization of the CPU with the programmer (See Reference 2).

Programmer Connection, Parallel

For a parallel interface (MS-DOS programmer only) the programmer is connected to the top port on the Bus Transmitter Module (IC697BEM713). Consult Reference 1 for a description of programming functions.

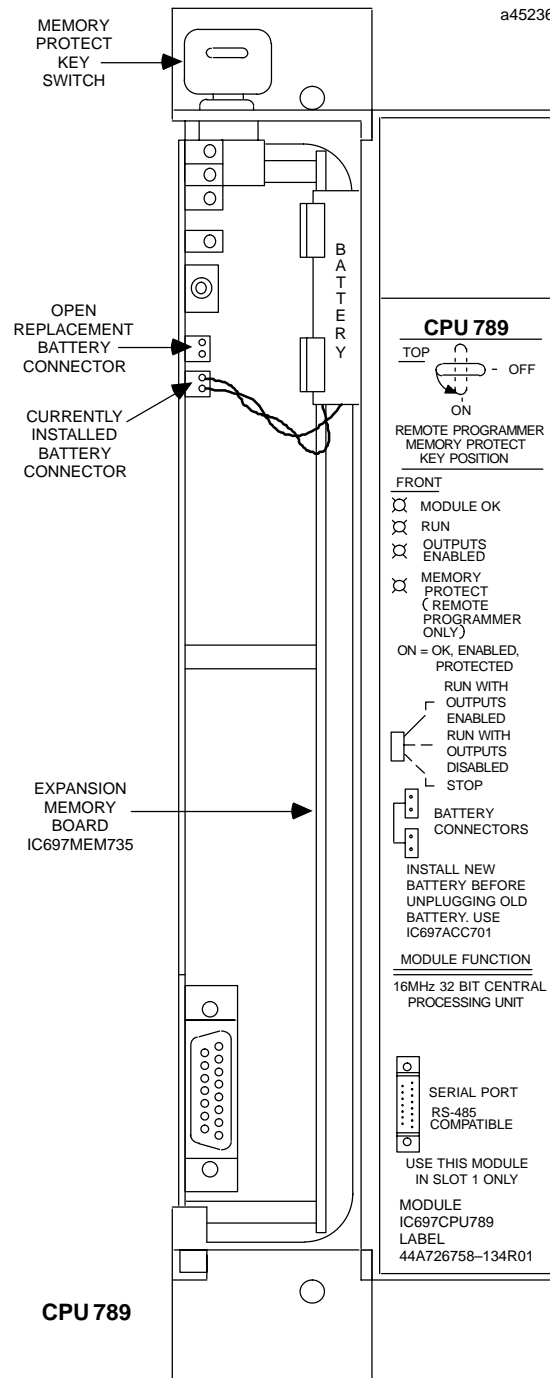

Figure 2. CPU 789 - Location of Major Features

GFK-0807D
August 1997

16 MHz, 32-Bit Expandable Central Processing Unit for IC66* Triple Modular Redundancy Systems

a47100

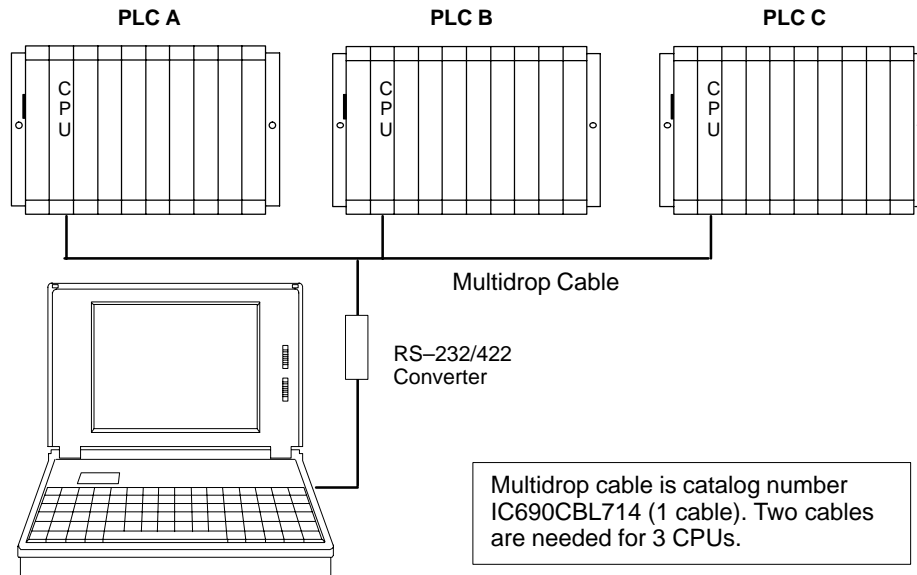

Figure 3. System Configuration, Serial Connection to Programmer

Serial Port

The 15-pin D-connector provides the connection to an RS-485 compatible serial port on the CPU as shown in Figure 3. This port provides a serial connection to a Work Station Interface board installed in the programming computer.

The serial connection can also be made from the serial port on the CPU to the serial port on the programming computer, or other serial device, through the RS-422/RS-485 to RS-232 Converter (IC690ACC900) or RS-232 to RS-422 Miniconverter (IC690ACC901). This connection can be made with available cables or you may build cables to fit the needs of your particular application. For more information on serial communications, see reference 3.

For more detailed information on configuration of TMR systems and communications between PLCs in

the system, refer to the *Modular Redundancy Flexible Triple Modular Redundant (TMR) System User's Manual*.

Programmer Connection, Ethernet TCP/IP

Connecting your programmer via an Ethernet TCP/IP network requires installation of an Ethernet Interface module in the PLC. This can be either the Ethernet Controller, IC697CMM741, or Ethernet Interface (Type 2), IC697CMM742. Before connecting your programmer and PLC to the Ethernet TCP/IP network you must set the IP address in the Ethernet Interface. After setting the IP address, connect the PLC and the programmer running Windows software to the Ethernet Interface.

For more detailed information on Ethernet TCP/IP, refer to the *TCP/IP Ethernet Communications (Type 2) User's Manual*, and the Windows programming manual, GFK-1295.

16 MHz, 32-Bit Expandable Central Processing Unit for IC66* Triple Modular Redundancy Systems

GFK-0807D
August 1997

Configuration

The IC697 CPU and I/O system is configured with MS-DOS or Windows based programming software. There are no DIP switches or jumpers used to configure the system. The CPU verifies the actual module and rack configuration at power-up and periodically during operation. The actual configuration must be the same as the programmed configuration. Deviations are reported to the CPU alarm processor function for configured fault response. Consult Reference 1 for a description of configuration functions.

Battery

A lithium battery (IC697ACC701) is installed as shown in Figure 2. This battery maintains program and data memory when power is removed and operates the calendar clock. Be sure to install the new battery before removing the old battery. If during power-up diagnostics a low battery is detected the Module OK LED (top) will not stay on. Specific indication of a low battery state is detailed in Reference 2.

Removing a Module

The instructions below should be followed when removing a module from its slot in a rack.

- Grasp the board firmly at the top and bottom of the board cover with your thumbs on the front of the cover and your fingers on the plastic clips on the back of the cover.
- Squeeze the rack clips on the back of the cover with your fingers to disengage the clip from the rack rail and pull the board firmly to remove it from the backplane connector.
- Slide the board along the card guide and remove it from the rack.

Table 1. References

Reference	Title
1	Programming Software User's Manual
2	Programmable Controller Reference Manual
3	Programmable Controller Installation Manual
4	IC66* Modular Redundancy Flexible Triple Modular Redundant (TMR) System User's Manual

GFK-0807D
August 1997

**16 MHz, 32-Bit Expandable Central Processing Unit
for IC66* Triple Modular Redundancy Systems**

Table 2. Specifications for IC697CPU789 †

Battery	
Shelf life	10 years at 20° C (68° F)
Memory retention	6 months nominal without applied power.
Current required from 5V bus	1.6 Amps (includes expansion memory board)
Time of Day Clock accuracy	" 3.5 seconds per day maximum
Elapsed Time Clock (internal timing) accuracy	" .01% maximum
Serial Port	
RS422/485 compatible	Programmer Serial Attachment
VME	System designed to support the VME standard C.1

† Refer to GFK-0867B, or later for product standards and general specifications.

Table 3. Ordering Information

Description	Catalog Number
Central Processor Unit, CPU 789 16 MHz, 32 Bit, Expandable for IC660/IC661 Triple Modular Redundancy Systems	IC697CPU789
512 Kbyte, 32-Bit CMOS Expansion Memory	IC697MEM735
Lithium Battery	IC697ACC701

Note: For Conformal Coat option, or Low Temperature Testing option please consult the factory for price and availability.

GFK-1215B
November 1999

64 MHz, 32-Bit Floating Point Central Processing Unit, 1 Mbyte Memory, for IC66* Triple Modular Redundancy Systems

Features

- Single slot CPU
- Provides 1 Mbyte of battery-backed memory in the same slot (up to 512 Kbytes available for use by ladder diagram application program)
- Supports floating point calculations
- Up to 12K discrete inputs and outputs (any mix - simplex mode only); 2048 voted discrete inputs, 2048 voted discrete outputs
- Up to 8K analog inputs (simplex mode only) and 8K analog outputs (simplex mode only); 1024 voted analog inputs
- 0.4 microseconds per boolean function
- 64 MHz, 80486DX2 microprocessor
- Supports IC660/IC661 I/O (and IC697I/O in simplex mode only)
- Programmed by MS-DOS®, or Windows® software products running on Windows® 95 or Windows NT® over Ethernet TCP/IP or through the SNP port.
- Configurable data and program memory
- Battery-backed calendar clock
- Three position operation mode switch
- Password controlled access
- Remote programmer keyswitch memory protection
- Four status LEDs
- Software configuration (No DIP switches or jumpers)
- Reference information inside front door
- In-system upgradable firmware

Functions

The CPM 790 is a single slot programmable controller CPU which allows floating point calculations. The CPM 790 is programmed and configured with MS-DOS or Windows based programming software for use in Emergency Shut-Down (ESD), fire and gas, and other critical control applications. It communicates with I/O and smart option modules over the rack mounted backplane (IC697CHS750, 782, 783, 790, 791) by way of the VME C.1 Standard format.

The CPM 790 must be used in conjunction with a Standalone C program which provides Triple Modular Redundancy (TMR) operating and autotest routines. It will not operate unless this program is included in the loaded application program.

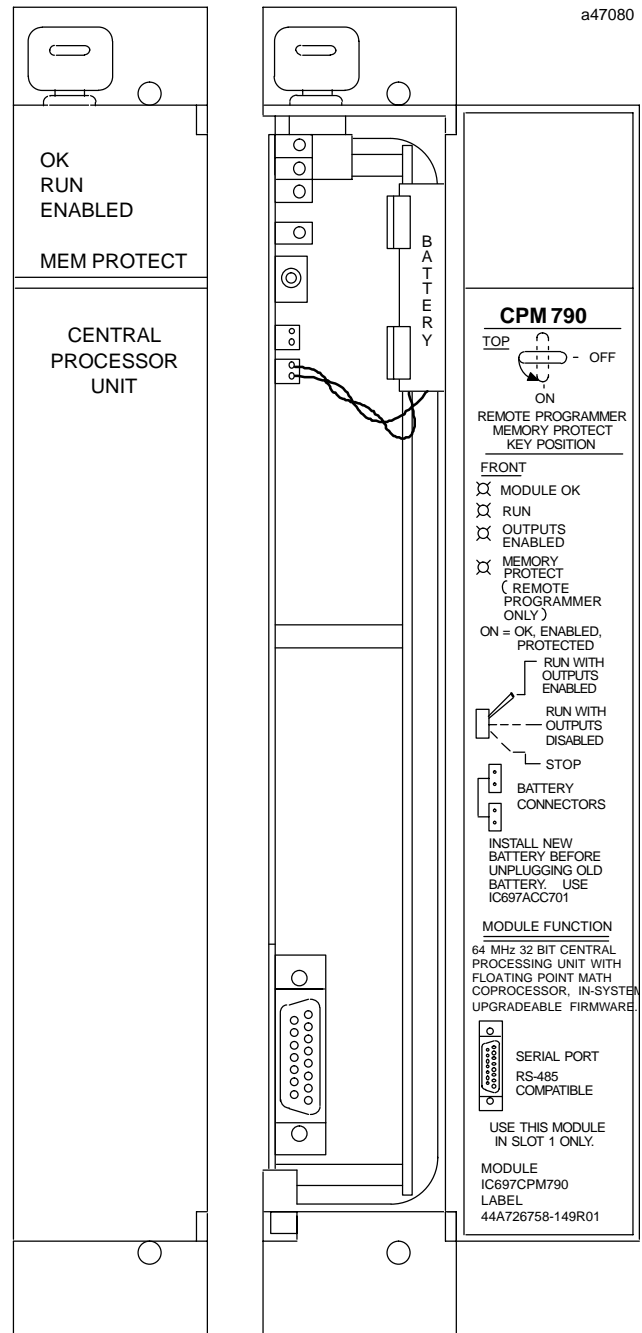

© MS-DOS, Windows, Windows 95, and Windows NT are registered trademarks of Microsoft Corporation.

GFK-1215B
November 1999

64 MHz, 32-Bit Floating Point Central Processing Unit, 1 Mbyte Memory, for IC66* Triple Modular Redundancy Systems

For detailed information on TMR systems, see Reference 4, the IC66* *Modular Redundancy Flexible Triple Modular Redundant (TMR) System User's Manual*. Supported option modules include IC697 LAN Interface modules, Programmable Coprocessor, Alphanumeric

Display Coprocessor, Bus Controller for IC660/661 I/O products, Communications modules, I/O Link Interface, and all of the IC697 family of discrete and analog I/O modules.

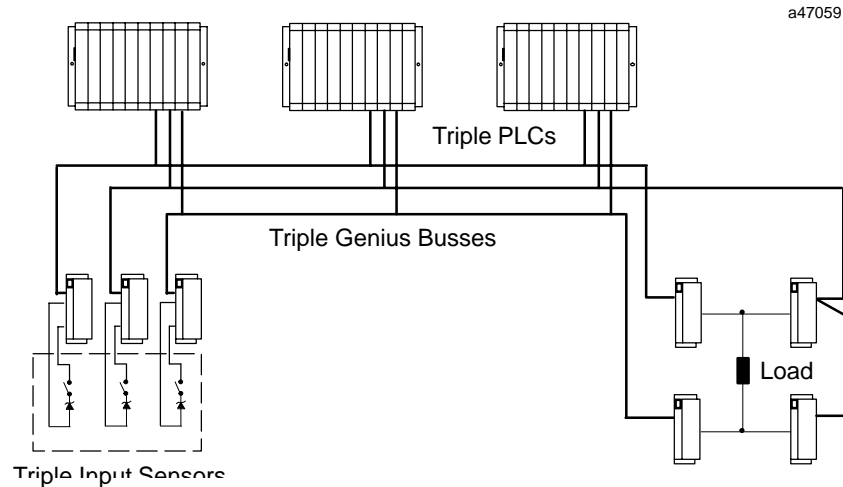

Figure 1. Typical GMR System Configuration

User Memory

Program and data memory for the CPM 790 is provided by a memory board with 1 Mbyte of battery-backed CMOS RAM. *512 Kbytes of this memory is available for the user's application program and data.* This memory board is an integral part of the CPM 790 module and is included with the module.

Flash Memory

This module uses flash memory for storage of the operating system firmware (*this module does not support storage of user program in the flash memory*). This allows updates of the firmware without disassembling the module or replacing EPROMs. The operating system firmware is updated by connecting a PC compatible computer to the module's serial port and running the Loader software included with the firmware floppy disk.

Operation, Protection, and Module Status

Operation of this module can be controlled by the three-position RUN/STOP switch or remotely by an attached programmer and programming software. Program and configuration data can be locked through software passwords or manually by the memory protect keyswitch. When the key is in the *protected* position, program and configuration data can

only be changed by a programmer connected parallel only (to the Bus Transmitter module). The status of a CPU is indicated by the four green LEDs on the front of the module.

Operating Temperature

The CPM 790 requires forced air cooling for proper operation in ambient temperatures greater than 40°C (104°F). A fan capable of 70 CFM (including filters) should be located beneath slot 1 of the rack containing the CPU.

Fan assemblies (IC697ACC721, IC697ACC724, and IC697ACC744) can be ordered for direct mounting on the IC697 rack. Refer to the applicable *Programmable Controller Installation Manual* for detailed information.

Installation

It is the responsibility of the OEM, system integrator, or end user to properly install the PLC equipment for safe and reliable operation. Product manuals provide detailed information about installation, startup, and proper use of the PLC equipment. The installation manual, shipped with your PLC programming software, describes how to properly install the equipment. If the PLC installation must comply with supported standards, such as FCC or CE Directives, please refer to the *Installation Requirements for Conformance to Standards*,

**64 MHz, 32-Bit Floating Point Central Processing Unit,
1 Mbyte Memory, for IC66* Triple Modular Redundancy Systems**

GFK-1215B
November 1999

shipped with the PLC programming software, for additional guidelines.

- Installation should not be attempted without referring to the applicable *Programmable Controller Installation Manual*.
- Connect the battery to either of the battery connectors on the module (see Figure 2).
- Put the toggle switch in the STOP position.
- Put the keyswitch in the *Memory Protection OFF* position.
- Make sure that rack power is off.
- Install the CPM 790 module in slot 1 of rack 0.
- Turn on power.

The module should power up and the top LED should blink. When the diagnostics have completed successfully, the top LED stays on and the second and third LEDs are off. The fourth LED is off if the keyswitch is in the OFF position. The CPU is now ready to be programmed (if connected parallel, the CPU can be programmed regardless of key position). After the program has been verified the toggle switch can be moved to the appropriate operation mode position. The LEDs indicate the position of the toggle switch, memory protection status, and the state of the program.

Programmer Connection, Parallel

For a parallel interface (MS-DOS programmer only) the programmer is connected to the top port on the Bus Transmitter Module (IC697BEM713). Consult Reference 1 for a description of programming functions.

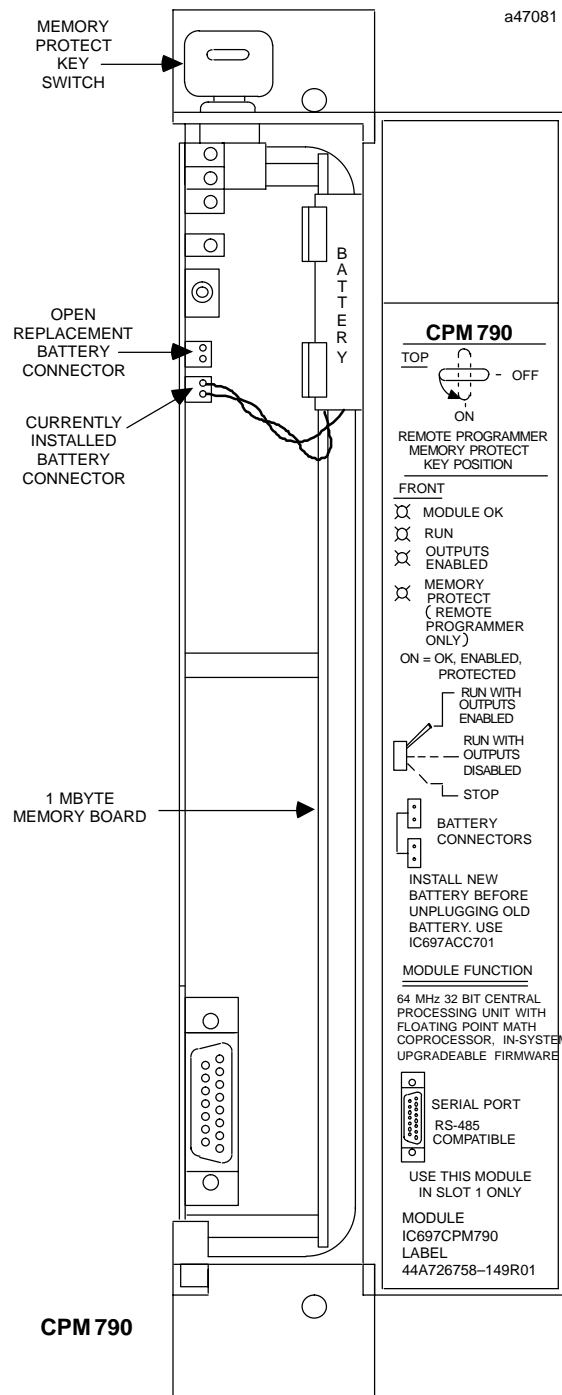

Figure 2. CPM 790 - Location of Major Features

GFK-1215B
November 1999

**64 MHz, 32-Bit Floating Point Central Processing Unit,
1 Mbyte Memory, for IC66* Triple Modular Redundancy Systems**

a47100

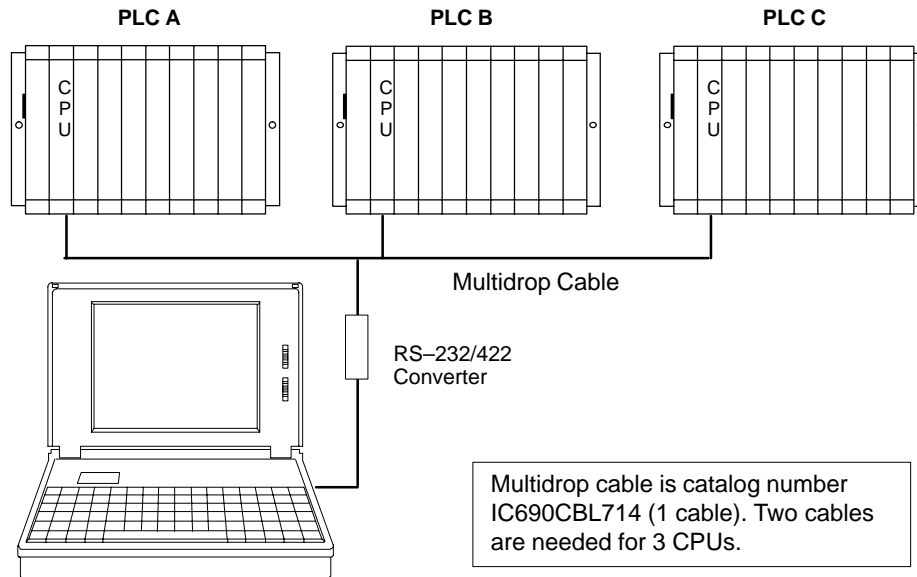

Figure 3. System Configuration, Serial Connection to Programmer

Serial Port

The 15-pin D-connector provides the connection to an RS-485 compatible serial port on the CPU (see Figure 3). This port provides a serial connection to a Work Station Interface board installed in the programming computer.

The serial connection can also be made from the serial port on the CPU to the serial port on the programming computer, or other serial device, through the RS-422/RS-485 to RS-232 Converter (IC690ACC900) or RS-232 to RS-422 Miniconverter (IC690ACC901). This connection can be made with available cables or you may build cables to fit the needs of your particular application. See reference 3 for more information on serial communications.

For more detailed information on configuration of TMR systems and communications between PLCs in the

system, refer to the *Modular Redundancy Flexible Triple Modular Redundant (TMR) System User's Manual*.

Programmer Connection, Ethernet TCP/IP

Connecting your programmer via an Ethernet TCP/IP network requires installation of an Ethernet Interface module in the PLC. This can be either the Ethernet Controller, IC697CMM741, or Ethernet Interface (Type 2), IC697CMM742. Before connecting your programmer and PLC to the Ethernet TCP/IP network you must set the IP address in the Ethernet Interface. After setting the IP address, connect the PLC and the programmer running Windows software to the Ethernet Interface.

For more detailed information on Ethernet TCP/IP, refer to the *TCP/IP Ethernet Communications (Type 2) User's Manual*, and the Windows programming manual, GFK-1295.

64 MHz, 32-Bit Floating Point Central Processing Unit, 1 Mbyte Memory, for IC66* Triple Modular Redundancy Systems

GFK-1215B
November 1999

Configuration

The IC697 CPU and I/O system is configured with MS-DOS or Windows based programming software. There are no DIP switches or jumpers used to configure the system. The CPU verifies the actual module and rack configuration at power-up and periodically during operation. The actual configuration must be the same as the programmed configuration. Deviations are reported to the CPU alarm processor function for configured fault response. Consult Reference 1 for a description of configuration functions.

Battery

A lithium battery (IC697ACC701) is installed as shown in Figure 2. This battery maintains program and data memory when power is removed and operates the calendar clock. Be sure to install the new battery before removing the old battery. If during power-up diagnostics a low battery is detected, the *MODULE OK* LED (top LED) will not stay on. Specific indication of a low battery state is detailed in Reference 2.

Removing a Module

The instructions below should be followed when removing a module from its slot in a rack.

- Grasp the board firmly at the top and bottom of the board cover with your thumbs on the front of the cover and your fingers on the plastic clips on the back of the cover.
- Squeeze the rack clips on the back of the cover with your fingers to disengage the clip from the rack rail and pull the board firmly to remove it from the backplane connector.
- Slide the board along the card guide and remove it from the rack.

Table 1. References

Reference	Title
1	Programming Software User's Manual
2	Programmable Controller Reference Manual
3	Programmable Controller Installation Manual
4	IC660/IC661 Modular Redundancy Flexible Triple Modular Redundant (TMR) System User's Manual

GFK-1215B
November 1999

**64 MHz, 32-Bit Floating Point Central Processing Unit,
1 Mbyte Memory, for IC66* Triple Modular Redundancy Systems**

Table 2. Specifications for IC697CPM790 †

Battery	
Shelf life	10 years at 20° C (68° F)
Memory retention	6 months nominal without applied power.
Current required from 5V bus	3.3 Amps nominal
Operating Temperature	0 to 60°C (32°F to 140°F); <i>70 CFM forced air required</i> 0 to 40°C (32°F to 104°F); <i>without forced air</i>
Time of Day Clock accuracy	" 3.5 seconds per day maximum
Elapsed Time Clock (internal timing) accuracy	" .01% maximum
Serial Port	
RS422/485 compatible	Programmer Serial Attachment
VME	System designed to support the VME standard C.1

† Refer to GFK-0867B, or later for product standards and general specifications.

Table 3. Ordering Information

Description	Catalog Number
Central Processing Unit 64 MHz, 32-Bit, Floating Point, 1 Mbyte Memory For IC66* Triple Modular Redundancy Systems	IC697CPM790
Lithium Battery	IC697ACC701
Rack Fan Assembly, 120 VAC	IC697ACC721
Rack Fan Assembly, 240 VAC	IC697ACC724
Rack Fan Assembly, 24 VDC	IC697ACC744

Note: For Conformal Coat option, or Low Temperature Testing option please consult the factory for price and availability.

GFK-0837C
August 1997

16 MHz, 32-Bit Floating Point Expandable Central Processing Unit for Hot Standby CPU Applications

Features

- Required for Hot Standby CPU applications
- Supports floating point calculation
- Single slot CPU
- 12K inputs and outputs (any mix)
- Up to 8K analog I/O
- 0.4 microseconds per boolean function
- 16MHz, 80386DX microprocessor
- Supports IC660/IC661 and IC697I/O products
- Programmed by MS-DOS® (IC641) based software products
- Supports up to 512 Kbytes of battery-backed expansion memory in the same slot
- Configurable data and program memory
- Battery-backed calendar clock
- Three position operation mode switch
- Password controlled access
- Keyswitch memory protection
- Four status LEDs
- Software configuration (No DIP switches or jumpers to set)
- Reference information inside front door.

Redundancy Features

In addition to the above features, the CPU 780 supports the redundancy features listed below.

- Bumpless switching between redundancy PLCs
- Synchronization of CPUs
- Redundant backup communications
- 20 ms scan extension (nominal)
- One scan switching (in most cases)
- Configurable backup data size
- On-line programming
- On-line repair
- No single point of failure
- Same or different program in Primary and Secondary PLCs
- Program control switching
- Symptom status bits and fault tables
- Memory parity and checksums

- Common I/O on IC660/IC661 bus
- Manual switching with pushbutton switch on Redundancy Communications Module

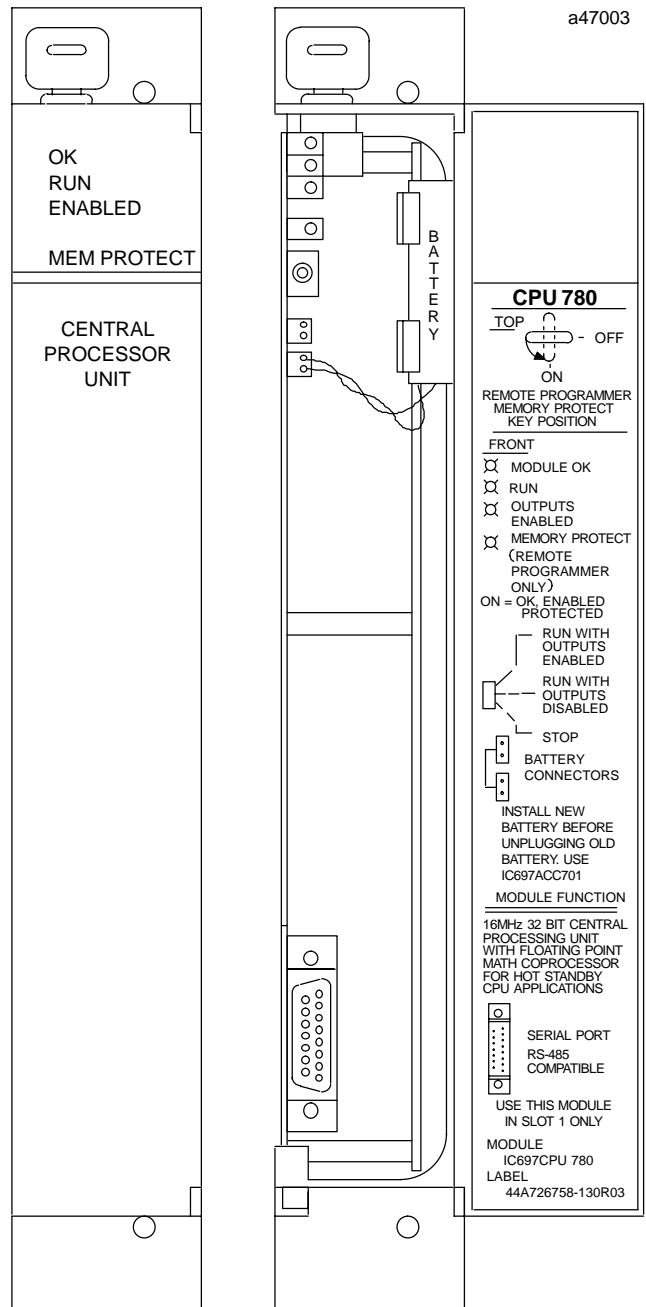

© MS-DOS is a registered trademark of Microsoft Corporation.

GFK-0837C
August 1997

16 MHz, 32-Bit Floating Point Expandable Central Processing Unit for Hot Standby CPU Applications

Functions

The CPU 780 is a single slot programmable controller CPU which allows floating point calculations and is required for Hot Standby CPU applications. The CPU 780 is programmed and configured by IC641 programming software to perform real time control of machines, processes and material handling systems.

The CPU 780 communicates with I/O and smart option modules over the rack mounted backplane (IC697CHS750, 790, 791) by way of the VME C.1 Standard format.

Supported option modules include all IC697 LAN interface modules, several Coprocessor modules, Bus Controller for IC660/IC661 I/O, Communications modules, and all of the IC697 family of discrete and analog I/O modules.

Program and data memory for the CPU 780 is available by the attachment of an expansion memory board with either 128 Kbytes, 256 Kbytes or 512 Kbytes of battery-backed CMOS RAM, or 256 Kbytes with 256 Kbytes of non-volatile flash memory. These memory boards provide

error checking through a CPU checksum routine with detected parity errors being reported to the CPU as they occur.

Operation of this module may be controlled by the three position RUN/STOP switch or remotely by an attached programmer and IC641 software. Program and configuration data can be locked through software passwords or manually by the memory protect key-switch. When the key is in the *protected* position, program and configuration data can only be changed by a programmer connected through parallel communications (i.e., via the Bus Transmitter module). The status of the CPU is indicated by the four green LEDs on the front of the module.

The CPU 780 is used as the CPU in a Hot Standby CPU Redundancy system. Two CPUs are required in a Hot Standby CPU redundancy system; one in the Primary PLC and one in the Secondary PLC. Each of the CPUs must be configured separately, with one configured as the *Primary* unit and one configured as the *Secondary* unit. The location of the CPU 780 modules in a typical Hot Standby CPU Redundancy system is shown in Figure 1.

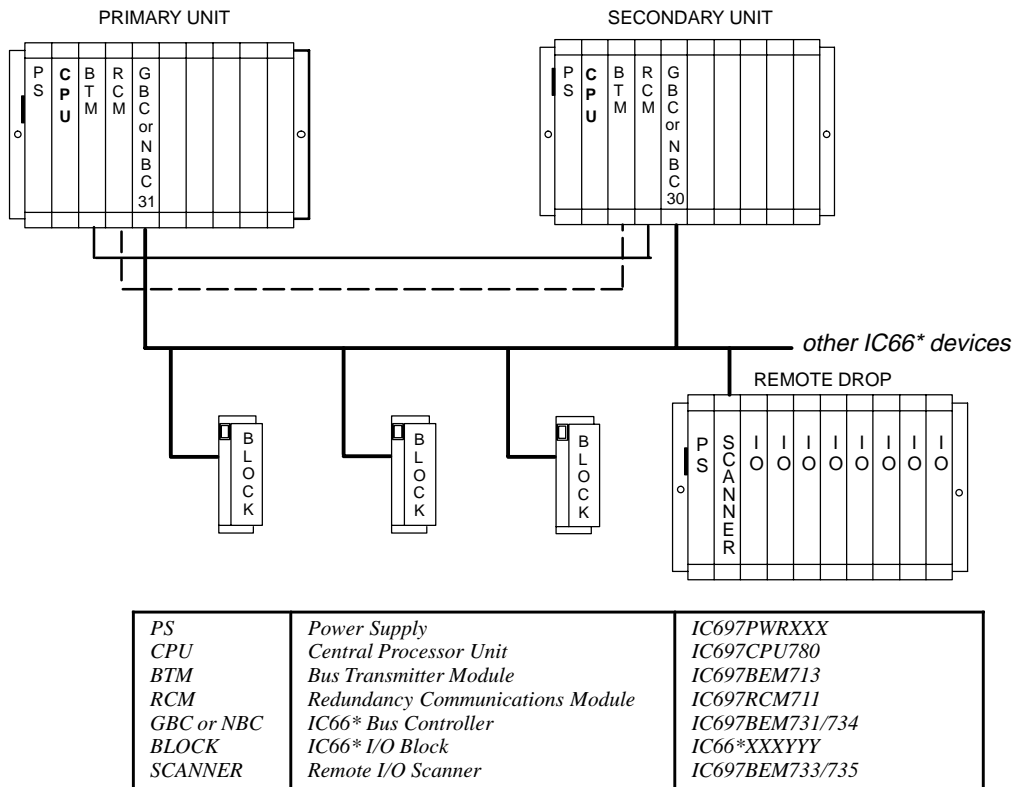

Figure 1. Hot Standby CPU Redundancy System Configuration

16 MHz, 32-Bit Floating Point Expandable Central Processing Unit for Hot Standby CPU Applications

GFK-0837C
August 1997

Installation

It is the responsibility of the OEM, system integrator, or end user to properly install the PLC equipment for safe and reliable operation. Product manuals provide detailed information about installation, startup, and proper use of the PLC equipment. The installation manual, shipped with your PLC programming software, describes how to properly install the equipment. If the PLC installation must comply with supported standards, such as FCC or CE Directives, please refer to the *Installation Requirements for Conformance to Standards*, shipped with the PLC programming software, for additional guidelines.

Installation should not be attempted without referring to the applicable *Programmable Controller Installation Manual* and the *Hot Standby CPU Redundancy Manual*.

- Align the expansion memory and CPU connectors.
- Align the captive screws on the memory board with the standoffs already installed on the CPU.
- Push the memory board onto the CPU connector ensuring that the mating screws remain aligned with their respective standoff.
- Screw each memory board screw into the standoffs with a #1 Phillips screwdriver, and tighten.
- Connect the battery to either of the battery connectors on the module.
- Put toggle switch in the STOP position.
- Put keyswitch in Memory Protection OFF position.
- Make sure rack power is off.
- Install in slot 1 of rack 0. (See Figure 1)
- Turn on power.

The module should power up and blink the top LED. When the diagnostics have completed successfully, the top LED stays on and the second and third LEDs are off.

The fourth LED is off if the keyswitch is in the OFF position. The CPU is now ready to be programmed. After the program has been verified the toggle switch may be moved to the appropriate operation mode position. The LEDs indicate the position of the toggle switch, memory protection status, and the state of the program.

Expansion Memory

The CPU 780 must have a CMOS RAM expansion memory board. The CMOS expansion memory board provides CMOS RAM memory of 128K, 256K, 256K

with 256K of non-volatile flash memory, or 512 Kbytes. These memory boards provide error checking through a CPU checksum routine. Memory parity errors are reported to the CPU when they occur. The battery which supports this memory is located on the main CPU board. (See Figure 2).

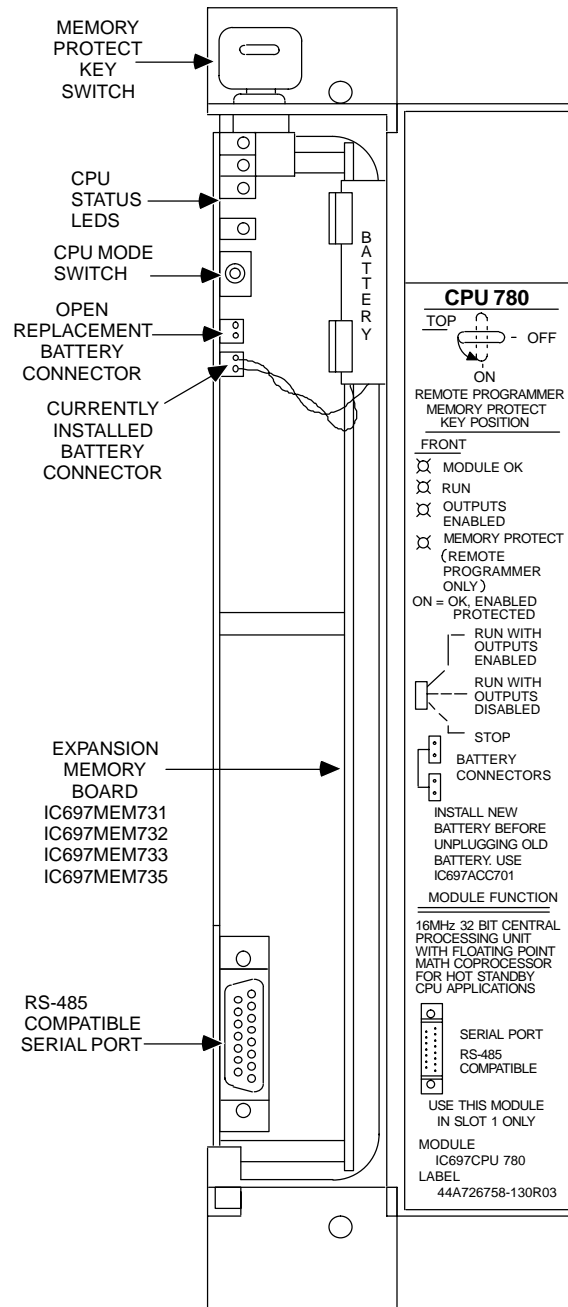

Figure 2. CPU 780 - Location of Major Features

GFK-0837C
August 1997

16 MHz, 32-Bit Floating Point Expandable Central Processing Unit for Hot Standby CPU Applications

Installation of a CMOS expansion memory board on the CPU will require initialization of the CPU with the programmer (See Reference 2).

Programmer Connection, Parallel

The programmer connects to the top port on the Bus Transmitter Module (IC697BEM713) system interface module for a parallel interface (as shown in Figure 1). Consult Reference 2 for a description of programming functions.

Serial Port

The 15-pin D-connector provides the connection to an

RS-485 compatible serial port on the CPU as shown in Figures 2 and 3. This port provides a serial connection to the programming computer.

The serial connection is made from the Standard Serial COM port on the CPU to the serial port on the programming computer, or other serial device, through the RS-422/RS-485 to RS-232 Converter (IC690ACC900) or RS-232 to RS-422 Miniconverter (IC690ACC901). This connection can be made with available cables or you may build cables to fit the needs of your particular application. For more information on serial communications, see Reference 3.

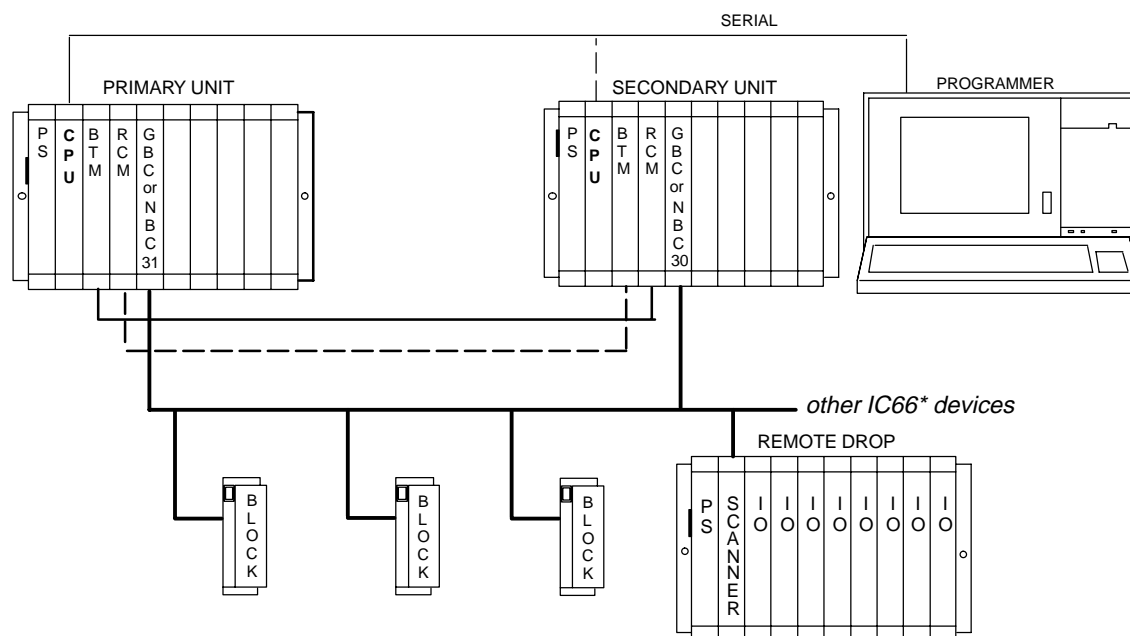

Figure 3. Hot Standby CPU Redundancy System Configuration with Serial Connection to Programmer

Note

When configuring a Hot Standby CPU Redundancy system the programmer must be connected to the CPU in the Primary unit to configure the Primary PLC and then moved to the CPU in the Secondary PLC to configure the Secondary PLC.

16 MHz, 32-Bit Floating Point Expandable Central Processing Unit for Hot Standby CPU Applications

GFK-0837C
August 1997

Configuration

The IC697 CPU and I/O system is configured with MS-DOS based programming software. There are no DIP switches or jumpers used to configure the system. The CPU verifies the actual module and rack configuration at power-up and periodically during operation. The actual configuration must be the same as the programmed configuration. Deviations are reported to the CPU alarm processor function for configured fault response. Consult Reference 1 for a description of configuration functions.

Batteries

A lithium battery (IC697ACC701) is installed as shown in Figure 2. This battery maintains program and data memory when power is removed and operates the calendar clock. Be sure to install the new battery before removing the old battery. If during power-up diagnostics a low battery is detected the Module OK LED (top) will not stay on. Specific indication of a low battery state is detailed in Reference 2.

Removing a Module

The following instructions should be followed when removing a CPU 780 module from its slot in a rack. If a fault in the CPU hardware is detected that is logged as FATAL, the CPU will go to STOP mode and control will be switched from the active unit (with the failed CPU) to the backup unit. Power can then be removed from the rack containing the failed CPU and the CPU replaced. If a failure is detected in the backup unit, you can simply remove power from the CPU rack and replace the module.

- Grasp the board firmly at the top and bottom of the board cover with your thumbs on the front of the cover and your fingers on the plastic clips on the back of the cover.
- Squeeze the rack clips on the back of the cover with your fingers to disengage the clip from the rack rail and pull the board firmly to remove it from the backplane connector.
- Slide the board along the card guide and remove it from the rack.

Table 1. Specifications for IC697CPU780 †

Battery Shelf Life	10 years at 20° C (68° F)
Memory Retention	6 months nominal without applied power
Current required from 5V Bus	1.6 Amps (includes expansion memory)
Time of Day Clock (internal timing) Accuracy	±3.5 seconds per day
Elapsed Time Clock	±.01% maximum
Serial Port	RS422/485 compatible, Programmer Serial Attachment
VME	System designed to support the VME standard C.1

† Refer to GFK-0867B, or later for product standards and general specifications.

Table 2. References

Reference	Title
1	Programming Software User's Manual
2	Programmable Controller Reference Manual
3	Programmable Controller Installation Manual
4	Hot Standby CPU Redundancy User's Guide

GFK-0837C
August 1997

16 MHz, 32-Bit Floating Point Expandable Central Processing Unit for Hot Standby CPU Applications

Table 3. Ordering Information

Description	Catalog Number
CPU 780, 32-Bit, 16 MHz, Expandable, Floating Point for Hot Standby CPU Redundancy applications	IC697CPU780
Redundancy Communications Module	IC697RCM711
Bus Transmitter Module	IC697BEM713
128 Kbyte, 32-Bit CMOS Expansion Memory	IC697MEM731
256 Kbyte, with 256 KBytes non-volatile flash memory, 32-Bit CMOS Expansion Memory	IC697MEM732
256 Kbyte, 32-Bit CMOS Expansion Memory	IC697MEM733
512 Kbyte, 32-Bit CMOS Expansion Memory	IC697MEM735
Lithium Battery	IC697ACC701

Note: For Conformal Coat option, or Low Temperature Testing option please consult the factory for price and availability.

GFK-1035C
August 1997

16 MHz, 32-Bit Floating Point, State Logic Central Processing Unit

Features

- Supports State Logic control programming
- Supports floating point calculations
- Single slot CPU
- 12K inputs and outputs (any mix)
- Up to 8K analog I/O
- 0.4 microseconds per boolean function
- 16 MHz, 80386DX microprocessor
- Supports IC660/IC661 and IC697I/O products
- Programmed by AD641 and IC641 (MS-DOS®) software products
- Provides 512 Kbytes of battery-backed expansion memory in the same slot
- Configurable data and program memory
- Battery-backed calendar clock
- Three position operation mode switch
- Password controlled access
- Keyswitch memory protection
- Four status LEDs
- Software configuration (No DIP switches or jumpers to set)
- Reference information inside front door

Functions

The CSE 784 is a single slot programmable controller CPU which provides State Logic control programming and floating point calculations. The CSE 784 may be programmed in State Logic, Relay Ladder Logic, and C to perform real-time control of machines, processes, and material handling systems. The AD641 software products are used to program the CSE 784 in State Logic; the IC641 (MS-DOS) software products are used to program in Relay Ladder Logic and C. The IC641 (MS-DOS) software is used to perform all configuration functions for the CSE 784.

Program and data memory for the State Logic CSE 784 is provided by a memory board with 512 Kbytes of battery-backed CMOS RAM. This memory board is an integral part of the CSE 784 module and does not need to be ordered separately.

The CSE 784 communicates with I/O and smart option modules over the rack mounted backplane

(IC697CHS750, 782, 783, 790, 791) by way of the VME C.1 Standard format.

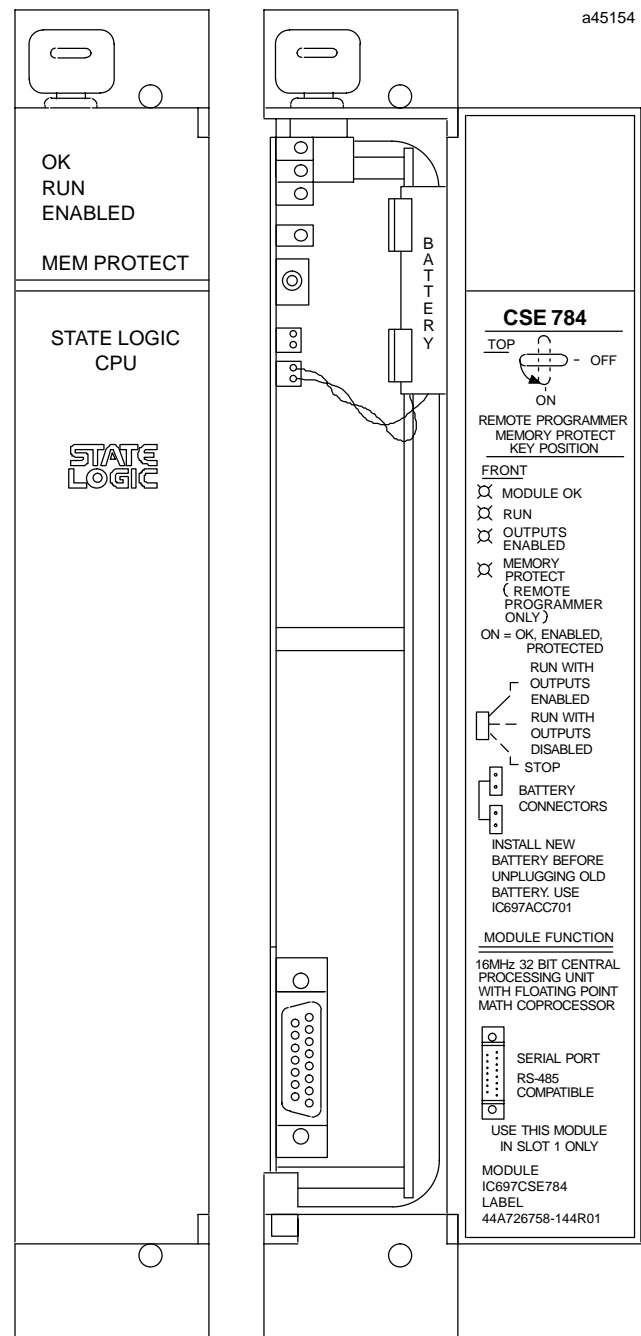

© MS-DOS is a registered trademark of Microsoft Corporation.

GFK-1035C
August 1997

16 MHz, 32-Bit Floating Point, State Logic Central Processing Unit

Supported option modules include all IC697 LAN interface modules, several Coprocessor modules, Bus Controller for IC660/IC661 I/O, Communications modules, and all of the IC697 family of discrete and analog I/O modules.

Operation of this module may be controlled by the three position RUN/STOP switch or remotely by an attached programmer, and AD641 or IC641 (MS-DOS) software. Program and configuration data can be locked through software passwords or manually by the memory protect keyswitch. When the key is in the protected position, program and configuration data cannot be changed. The status of the CPU is indicated by the four green LEDs on the front of the module.

Installation

It is the responsibility of the OEM, system integrator, or end user to properly install the PLC equipment for safe and reliable operation. Product manuals provide detailed information about installation, startup, and proper use of the PLC equipment. The installation manual, shipped with your PLC programming software, describes how to properly install the equipment. If the PLC installation must comply with supported standards, such as FCC or CE Directives, please refer to the *Installation Requirements for Conformance to Standards*, shipped with the PLC programming software, for additional guidelines.

Installation should not be attempted without referring to the applicable hardware installation manual.

- Connect the battery to either of the battery connectors on the module.
- Put toggle switch in the STOP position.
- Put keyswitch in Memory Protection OFF position.
- Make sure rack power is off.
- Install in slot 1 of rack 0. (See Figure 2)
- Turn on power.

The module should power up and blink the top LED. When the diagnostics have completed successfully, the top LED stays on and the second and third LEDs are off.

The fourth LED is off if the keyswitch is in the OFF position. The CPU is now ready to be programmed. After the program has been verified the toggle switch may be moved to the appropriate operation mode position. The LEDs indicate the position of the toggle switch, memory protection status, and the state of the program.

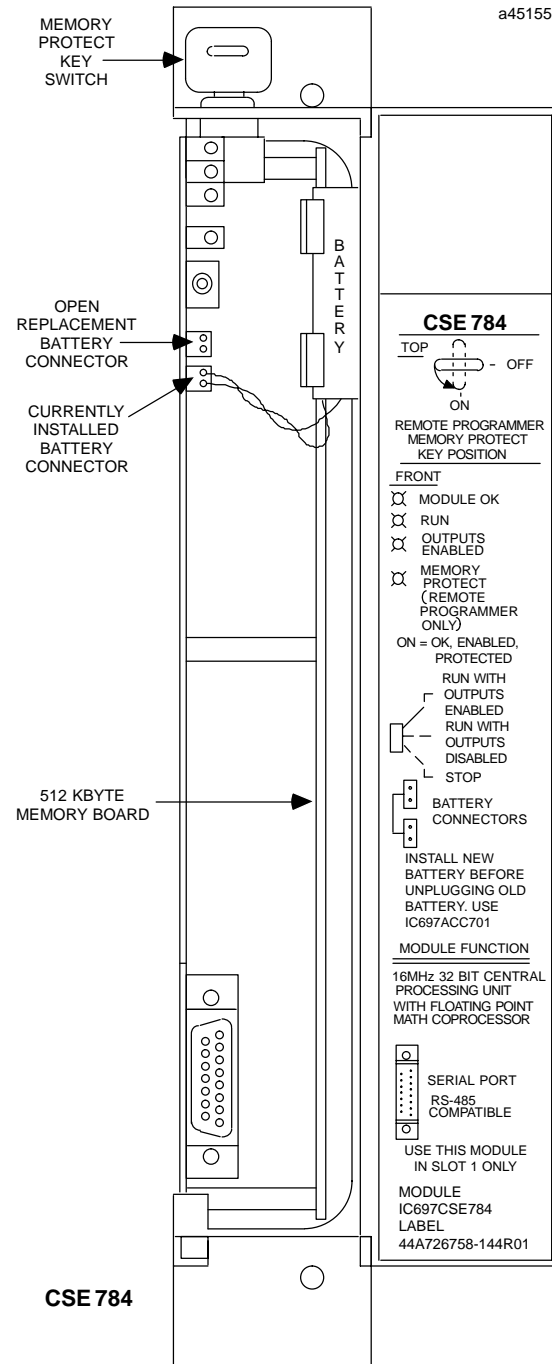

Figure 1. CSE 784 - Location of Major Features

The State Logic operating system is provided on a floppy disk with the CSE 784. The IC641 (MS-DOS) programming software is used to load the operating system into the CSE 784 CPU module. For information on loading the operating system, see the *State Logic Control System User's Manual*.

16 MHz, 32-Bit Floating Point, State Logic Central Processing Unit

GFK-1035C
August 1997

Serial Port

The 15-pin D-connector provides the connection to an RS-485 compatible serial port as shown in Figure 2.

The serial connection is made from the Standard Serial COM port on the CPU to the serial port on the programming computer, or other serial device, through the RS-422/RS-485 to RS-232 Converter (IC690ACC900) or RS-232 to RS-422 Miniconverter (IC690ACC901).

This serial connection can be made with available cables or you may build cables to fit the needs of your particular application. For more information on serial communications, see Reference 3.

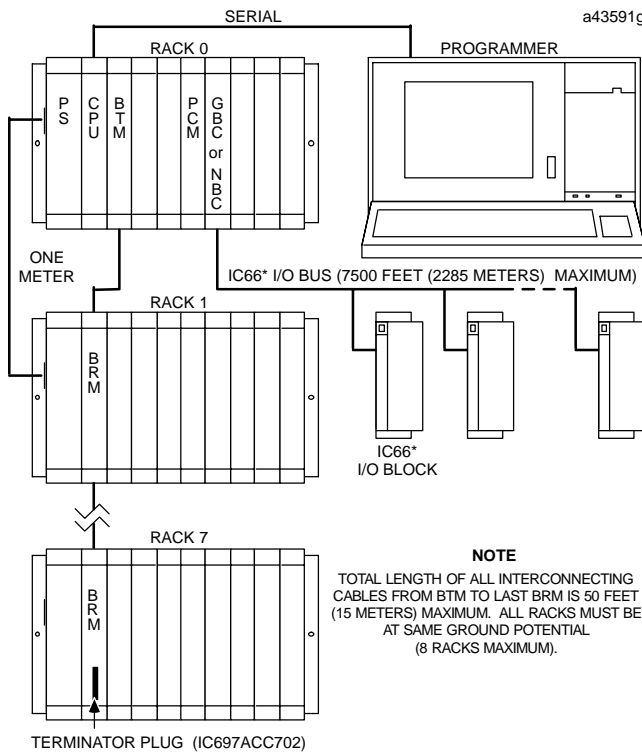

Figure 2. System Configuration, Serial Connection to Programmer

Configuration

The IC697 CPU and I/O system is configured with IC641 (MS-DOS) programming software. There are no DIP switches or jumpers used to configure the system. The CPU verifies the actual module and rack configuration at power-up and periodically during operation. The actual configuration must be the same as the programmed configuration. Deviations are reported to the CPU alarm processor function for configured fault response. Consult Reference 1 for a description of configuration functions.

Batteries

A lithium battery (IC697ACC701) is installed as shown in Figure 1. This battery maintains program and data memory when power is removed and operates the calendar clock. Be sure to install the new battery before removing the old battery. If during power-up diagnostics a low battery is detected the Module OK LED (top) will not stay on. Specific indication of a low battery state is detailed in Reference 2.

Removing a Module

The following instructions should be followed when removing a module from its slot in a rack.

- Grasp the board firmly at the top and bottom of the board cover with your thumbs on the front of the cover and your fingers on the plastic clips on the back of the cover.
- Squeeze the rack clips on the back of the cover with your fingers to disengage the clip from the rack rail and pull the board firmly to remove it from the backplane connector.
- Slide the board along the card guide and remove it from the rack.

GFK-1035C
August 1997

16 MHz, 32-Bit Floating Point, State Logic Central Processing Unit

Table 1. Specifications for IC697CSE784 †

Battery Shelf Life	10 years at 20° C (68° F)
Memory Retention	6 months nominal without applied power
Current required from 5V Bus	1.6 Amps (includes expansion memory)
Time of Day Clock (internal timing) Accuracy	±3.5 seconds per day
Elapsed Time Clock	±.01% maximum
Serial Port	RS422/485 compatible, Programmer Serial Attachment
VME	System designed to support the VME standard C.1

† Refer to GFK-0867B, or later for product standards and general specifications.

Table 2. References

Reference	Title
1	Programming Software User's Manual
2	Programmable Controller Reference Manual
3	Programmable Controller Installation Manual
4	State Logic Control System User's Manual

Table 3. Ordering Information

Description	Catalog Number
CSE 784, 16 MHz, 32-Bit, Floating Point, State Logic	IC697CSE784
Lithium Battery	IC697ACC701

Note: For Conformal Coat option, or Low Temperature Testing option please consult the factory for price and availability.

GFK-1036B
August 1997

64 MHz, 32-Bit Floating Point State Logic Central Processing Unit

Features

- Supports State Logic control programming
- Supports floating point calculations
- Single slot CPU.
- 12K inputs and outputs (any mix).
- Up to 8K analog I/O.
- 0.4 microseconds per boolean function.
- 64MHz, 80486DX2 microprocessor.
- Supports IC660/IC661 and IC697I/O products.
- Programmed by AD641 and IC641 (MS-DOS®) software products.
- Provides 512 Kbytes of battery-backed memory in the same slot.
- Configurable data and program memory.
- Battery-backed calendar clock.
- Three position operation mode switch.
- Password controlled access.
- Remote programmer keyswitch memory protection
- Four status LEDs.
- Software configuration (No DIP switches or jumpers to set).
- Reference information inside front door.
- In-system upgradable firmware.

Functions

The CSE 924 is a single slot programmable controller CPU which provides State Logic control programming and floating point calculations. The CSE 924 may be programmed in State Logic, Relay Ladder Logic, and C to perform real-time control of machines, processes, and material handling systems.

The AD641 software products are used to program the CSE 924 in State Logic; the IC641 (MS-DOS) software products are used to program in Relay Ladder Logic and C. The IC641 (MS-DOS) software is also used to perform all configuration functions for the CSE 924.

The CSE 924 communicates with I/O and smart option modules over the rack mounted backplane (IC697CHS750, 782, 783, 790, 791) by way of the VME C.1 Standard format.

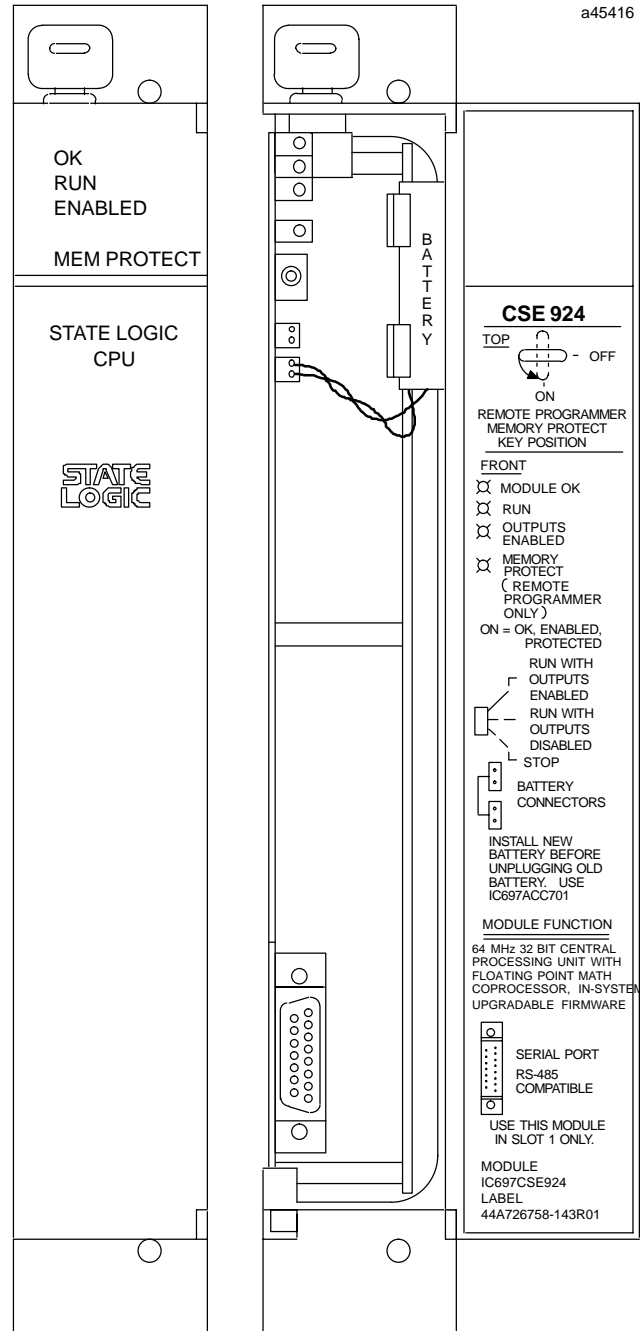

© MS-DOS is a registered trademark of Microsoft Corporation.

GFK-1036B
August 1997

64 MHz, 32-Bit Floating Point State Logic Central Processing Unit

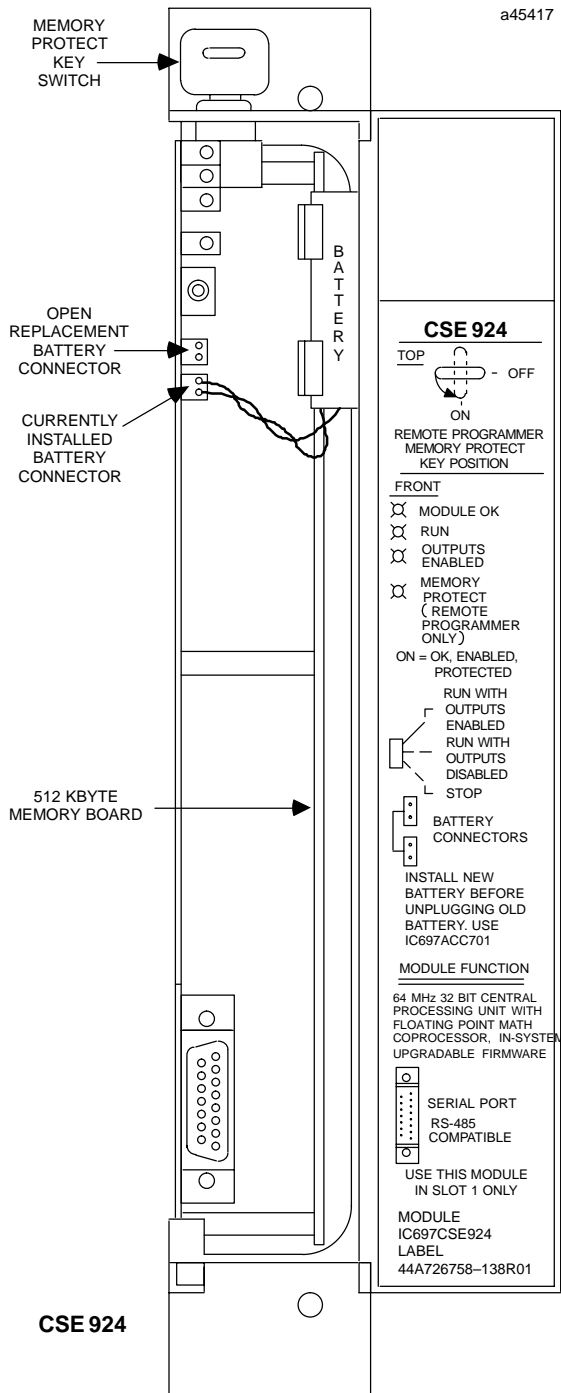

Figure 1. CSE 924 - Location of Major Features

Supported option modules include IC697 LAN Interface modules, Programmable Coprocessor, Alphanumeric Display Coprocessor, Bus Controller for IC660/IC66II/O products, Communications modules,

I/O Link Interface, and all of the IC697 family of discrete and analog I/O modules.

Program and data memory for the CSE 924 is provided by a memory board with 512 Kbytes of battery-backed CMOS RAM. This memory board is an integral part of the CSE 924 module and does not need to be ordered separately.

Operation of this module may be controlled by the three-position RUN/STOP switch or remotely by an attached programmer, and AD641 or IC641 (MS-DOS) software. Program and configuration data can be locked through software passwords or manually by the memory protect keyswitch. When the key is in the protected position, program and configuration data cannot be changed. The status of a CPU is indicated by the four green LEDs on the front of the module.

The CSE 924 requires forced air cooling for proper operation in ambient temperatures greater than 40°C (104°F). A fan capable of 70 CFM (including filters) should be located beneath slot 1 of the rack containing the CPU.

Fan assemblies (IC697ACC 721 and IC697ACC724) can be ordered for direct mounting on the IC697 rack. Refer to the applicable *Programmable Controller Installation Manual* for detailed information.

Installation

It is the responsibility of the OEM, system integrator, or end user to properly install the PLC equipment for safe and reliable operation. Product manuals provide detailed information about installation, startup, and proper use of the PLC equipment. The installation manual, shipped with your PLC programming software, describes how to properly install the equipment. If the PLC installation must comply with supported standards, such as FCC or CE Directives, please refer to the *Installation Requirements for Conformance to Standards*, shipped with the PLC programming software, for additional guidelines.

- Installation should not be attempted without referring to the applicable *Programmable Controller Installation Manual*.
- Connect the battery to either of the battery connectors on the module (see Figure 1).
- Put the toggle switch in the STOP position.
- Put the keyswitch in the *Memory Protection OFF* position.

64 MHz, 32-Bit Floating Point State Logic Central Processing Unit

GFK-1036B
August 1997

- Make sure that rack power is off.
- Install the CSE 924 module in slot 1 of rack 0 (see Figure 2).
- Turn on power.

The module should power up and the top LED should blink. When the diagnostics have completed successfully, the top LED stays on and the second and third LEDs are off. The fourth LED is off if the keyswitch is in the OFF position. The CPU is now ready to be programmed.

After the program has been verified the toggle switch may be moved to the appropriate operation mode position. The LEDs indicate the position of the toggle switch, memory protection status, and the state of the program.

The IC641 (MS-DOS) software is also used to load the State Logic operating system into the CSE 924 CPU module. The operating system is provided on a floppy disk with the CSE 924. For information on loading the operating system, see the *State Logic Control System User's Manual*.

Serial Port

The 15-pin D-connector provides the connection to an RS-485 compatible serial port on the CPU as shown in Figure 1.

The serial connection is made from the serial port on the CPU to the serial port on the programming computer, or other serial device, through the RS-422/RS-485 to RS-232 Converter (IC690ACC900) or RS-232 to RS-422 Miniconverter (IC690ACC901). This connection can be made with available cables or you may build cables to fit the needs of your particular application. See reference 3 for more information on serial communications.

Configuration

The IC697 CPU and I/O system is configured with IC641 (MS-DOS) programming software. There are no DIP switches or jumpers used to configure the system. The CPU verifies the actual module and rack configuration at power-up and periodically during operation. The actual configuration must be the same as the programmed configuration. Deviations are reported to the CPU alarm processor function for configured fault response. Consult Reference 1 for a description of configuration functions.

Batteries

A lithium battery (IC697ACC701) is installed as shown in Figure 1. This battery maintains program and data memory when power is removed and operates the calendar clock. Be sure to install the new battery before removing the old battery. Specific indication of a low battery state is detailed in Reference 2.

Removing a Module

The instructions below should be followed when removing a module from its slot in a rack.

- Grasp the board firmly at the top and bottom of the board cover with your thumbs on the front of the cover and your fingers on the plastic clips on the back of the cover.
- Squeeze the rack clips on the back of the cover with your fingers to disengage the clip from the rack rail and pull the board firmly to remove it from the backplane connector.
- Slide the board along the card guide and remove it from the rack.

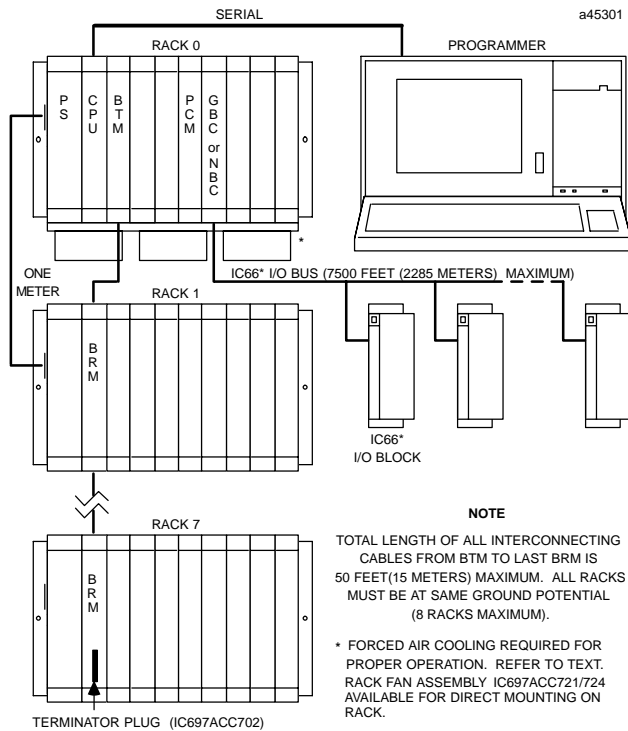

Figure 2. System Configuration, Serial Connection to Programmer

GFK-1036B
August 1997

64 MHz, 32-Bit Floating Point State Logic Central Processing Unit

Table 1. References

Reference	Title
1	Programming Software User's Manual
2	Programmable Controller Reference Manual
3	Programmable Controller Installation Manual
4	State Logic Control System User's Manual

Table 2. Specifications for IC697CSE924 †

Battery	
Shelf life	10 years at 20° C (68° F)
Memory retention	6 months nominal without applied power.
Current required from 5V bus	3.3 Amps nominal
Operating Temperature	0 to 60°C (32°F to 140°F); 70 CFM forced air required 0 to 40°C (32°F to 104°F); without forced air
Time of Day Clock accuracy	" 3.5 seconds per day maximum
Elapsed Time Clock (internal timing) accuracy	" .01% maximum
Serial Port	
RS422/485 compatible	Programmer Serial Attachment
VME	System designed to support the VME standard C.1

† Refer to GFK-0867B, or later for product standards and general specifications.

Table 3. Ordering Information

Description	Catalog Number
Central Processing Unit CSE 924, 64 MHz, 32-Bit, Floating Point, State Logic	IC697CSE924
Lithium Battery	IC697ACC701
Rack Fan Assembly, 120 VAC	IC697ACC721
Rack Fan Assembly, 240 VAC	IC697ACC724

Note: For Conformal Coat option, or Low Temperature Testing option please consult the factory for price and availability.

GFK-1167C
November 1999

**64 MHz, 32-Bit Floating Point Central Processing Unit
1 Mbyte Memory, State Logic**

Features

- Supports State Logic control programming
- Supports floating point calculations
- Single slot CPU.
- 12K inputs and outputs (any mix).
- Up to 8K analog I/O.
- 0.4 microseconds per boolean function.
- 64MHz, 80486DX2 microprocessor.
- Supports IC660/IC661 and IC697I/O products.
- Programmed by AD641 and IC641 (MS-DOS®) software products.
- Provides 1 Mbyte of battery-backed memory in the same slot.
- Configurable data and program memory.
- Battery-backed calendar clock.
- Three position operation mode switch.
- Password controlled access.
- Remote programmer keyswitch memory protection
- Four status LEDs.
- Software configuration (No DIP switches or jumpers to set).
- Reference information inside front door.
- In-system upgradable firmware.

Functions

The CSE 925 is a single slot programmable controller CPU which provides State Logic control programming and floating point calculations. The CSE 925 can be programmed in State Logic, Relay Ladder Logic, and C to perform real-time control of machines, processes, and material handling systems.

The AD641 software products are used to program the CSE 925 in State Logic; the IC641 (MS-DOS) software products are used to program in Relay Ladder Logic and C. The IC641 (MS-DOS) software is also used to perform all configuration functions for the CSE 925.

The CSE 925 communicates with I/O and smart option modules over the rack mounted backplane (IC697CHS750, 782, 783, 790, 791) by way of the VME C.1 Standard format.

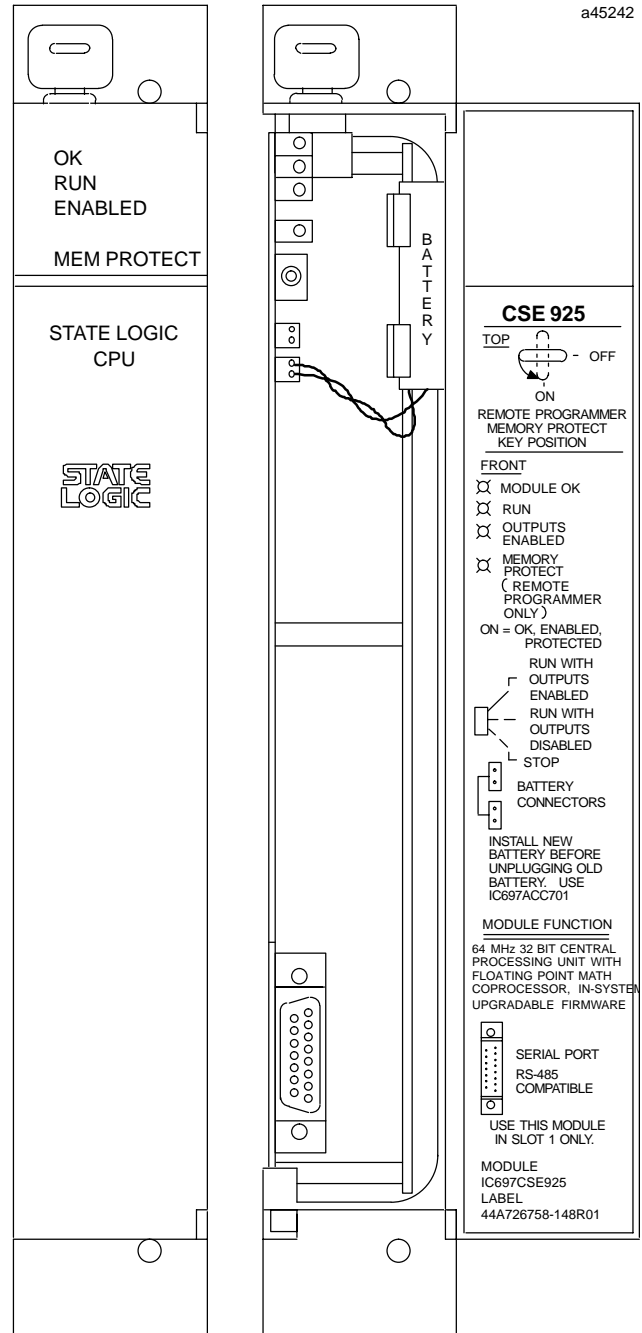

© MS-DOS is a registered trademark of Microsoft Corporation.

GFK-1167C
November 1999

64 MHz, 32-Bit Floating Point Central Processing Unit 1 Mbyte Memory, State Logic

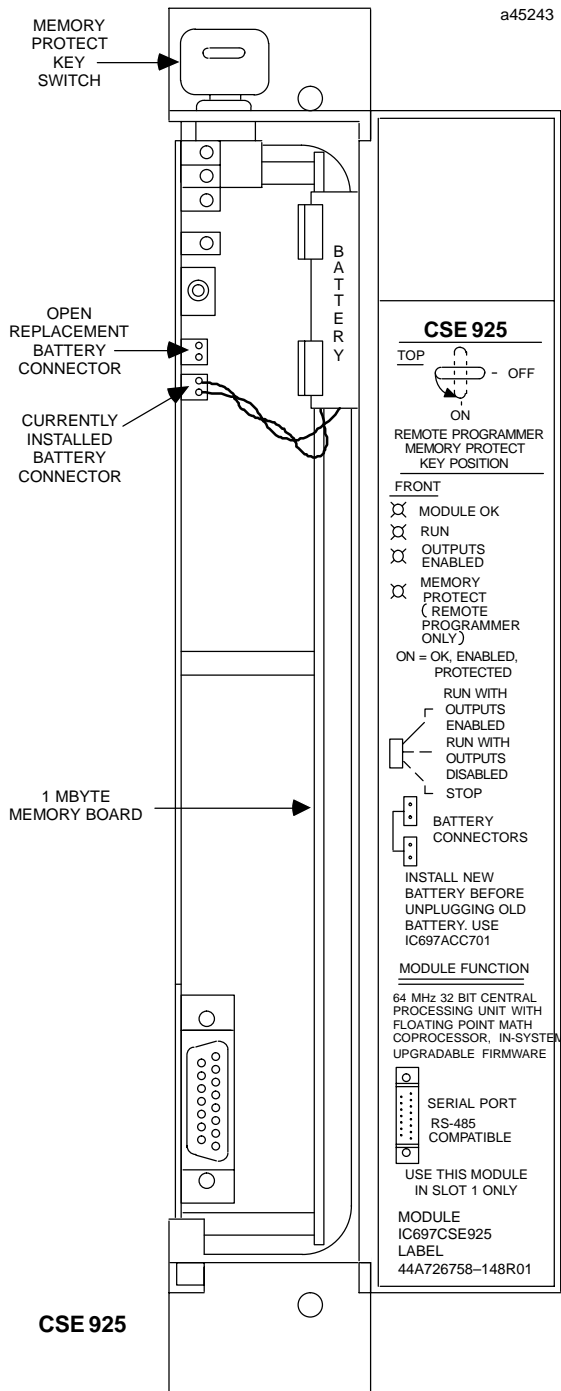

Figure 1. CSE 925 - Location of Major Features

Supported option modules include IC697 LAN Interface modules, Programmable Coprocessor, Alphanumeric Display Coprocessor, Bus Controller for IC660/IC661 I/O products, Communications modules, I/O Link Interface,

and all of the IC697 family of discrete and analog I/O modules.

User Memory

Program and data memory for the CSE 925 is provided by a memory board with 1 Mbyte of battery-backed CMOS RAM. This memory board is an integral part of the CSE 925 module and does not need to be ordered separately.

Operation, Protection, and Module Status

Operation of this module can be controlled by the three-position RUN/STOP switch or remotely by an attached programmer, and AD641 or IC641 (MS-DOS) software. Program and configuration data can be locked through software passwords or manually by the memory protect keyswitch. When the key is in the protected position, program and configuration data cannot be changed. The status of a CPU is indicated by the four green LEDs on the front of the module.

The CSE 925 requires forced air cooling for proper operation in ambient temperatures greater than 40°C (104°F). A fan capable of 70 CFM (including filters) should be located beneath slot 1 of the rack containing the CPU.

Rack Fan Assemblies (IC697ACC721, IC697ACC724, and IC697ACC744) can be ordered for direct mounting on the IC697 rack. Refer to the applicable *Programmable Controller Installation Manual* for detailed information.

Installation

It is the responsibility of the OEM, system integrator, or end user to properly install the PLC equipment for safe and reliable operation. Product manuals provide detailed information about installation, startup, and proper use of the PLC equipment. The installation manual, shipped with your PLC programming software, describes how to properly install the equipment. If the PLC installation must comply with supported standards, such as FCC or CE Directives, please refer to the *Installation Requirements for Conformance to Standards*, shipped with the PLC programming software, for additional guidelines.

- Installation should not be attempted without referring to the applicable *Programmable Controller Installation Manual*.
- Connect the battery to either of the battery connectors on the module (see Figure 1).
- Put the toggle switch in the STOP position.
- Put the keyswitch in the *Memory Protection OFF* position.

**64 MHz, 32-Bit Floating Point Central Processing Unit
1 Mbyte Memory, State Logic**

GFK-1167C
November 1999

- Make sure that rack power is off.
- Install the CSE 925 module in slot 1 of rack 0 (see Figure 2).
- Turn on power.

The module should power up and the top LED should blink. When the diagnostics have completed successfully, the top LED stays on and the second and third LEDs are off. The fourth LED is off if the keyswitch is in the OFF position. The CPU is now ready to be programmed.

After the program has been verified the toggle switch may be moved to the appropriate operation mode position. The LEDs indicate the position of the toggle switch, memory protection status, and the state of the program.

The IC641 (MS-DOS) software is also used to load the State Logic operating system into the CSE 925 CPU module. The operating system is provided on a floppy disk with the CSE 925. The operating system is stored in flash memory on the module. For information on loading the operating system, see the *State Logic Control System User's Manual*.

Serial Port

The 15-pin D-connector provides the connection to an RS-485 compatible serial port on the CPU as shown in Figure 2.

The serial connection is made from the serial port on the CPU to the serial port on the programming computer, or other serial device, through the RS-422/RS-485 to RS-232 Converter (IC690ACC900) or RS-232 to RS-422 Miniconverter (IC690ACC901). This connection can be made with available cables or you may build cables to fit the needs of your particular application. See reference 3 for more information on serial communications.

Configuration

The IC697 CPU and I/O system is configured with IC641 (MS-DOS) programming software. There are no DIP switches or jumpers used to configure the system. The CPU verifies the actual module and rack configuration at power-up and periodically during operation. The actual configuration must be the same as the programmed configuration. Deviations are reported to the CPU alarm processor function for configured fault response. Consult Reference 1 for a description of configuration functions.

Batteries

A lithium battery (IC697ACC701) is installed as shown in Figure 1. This battery maintains program and data memory when power is removed and operates the calendar clock. Be sure to install the new battery before removing the old battery. Specific indication of a low battery state is detailed in Reference 2.

Removing a Module

The instructions below should be followed when removing a module from its slot in a rack.

- Grasp the board firmly at the top and bottom of the board cover with your thumbs on the front of the cover and your fingers on the plastic clips on the back of the cover.
- Squeeze the rack clips on the back of the cover with your fingers to disengage the clip from the rack rail and pull the board firmly to remove it from the backplane connector.
- Slide the board along the card guide and remove it from the rack.

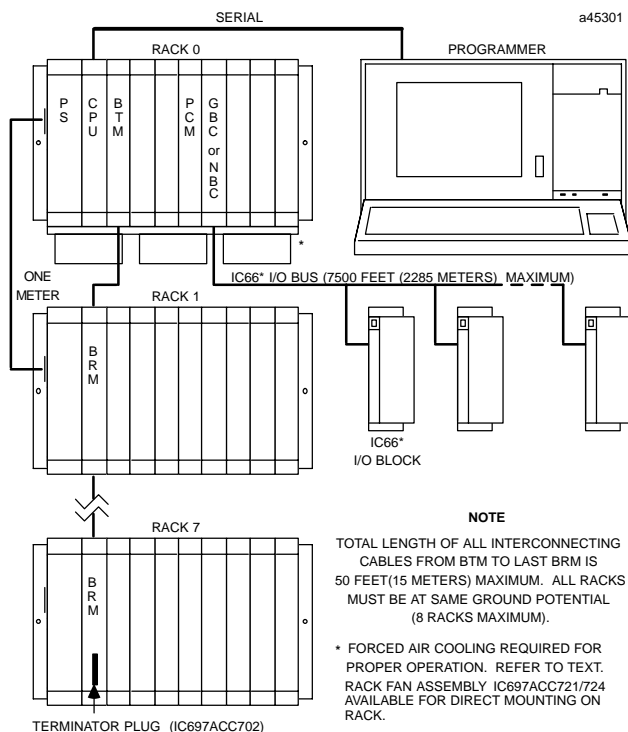

Figure 2. System Configuration, Serial Connection to Programmer

GFK-1167C
November 1999

**64 MHz, 32-Bit Floating Point Central Processing Unit
1 Mbyte Memory, State Logic**

Table 1. References

Reference	Title
1	Programming Software User's Manual
2	Programmable Controller Reference Manual
3	Programmable Controller Installation Manual
4	State Logic Control System User's Manual

Table 2. Specifications for IC697CSE925 †

Battery	
Shelf life	10 years at 20° C (68° F)
Memory retention	6 months nominal without applied power.
Current required from 5V bus	3.3 Amps nominal
Time of Day Clock accuracy	" 3.5 seconds per day maximum
Elapsed Time Clock (internal timing) accuracy	" .01% maximum
Serial Port	
RS422/485 compatible	Programmer Serial Attachment
VME	System designed to support the VME standard C.1

† Refer to GFK-0867B, or later for product standards and general specifications.

Table 3. Ordering Information

Description	Catalog Number
Central Processing Unit - 64 MHz, 32-Bit, Floating Point, 1 Mbyte Memory, State Logic	IC697CSE925
Lithium Battery	IC697ACC701
Rack Fan Assembly, 120 VAC	IC697ACC721
Rack Fan Assembly, 240 VAC	IC697ACC724
Rack fan Assembly, 24 VDC	IC697ACC744

Note: For Conformal Coat option, or Low Temperature Testing option please consult the factory for price and availability.

Expansion Memory

IC697MEM713/715/717/719

GFK-0160F
August 1997

CMOS Expansion Memory

Features

- Available in 64, 128, 256 and 512 Kbytes
- For expansion of CPU 771, CPU 772, or PCM
- Memory retained by battery on CPU or PCM
- Does not require additional slot
- Configurable for data and program storage
- Error checking by CPU checksum routine
- No tools required for installation
- Field Installable

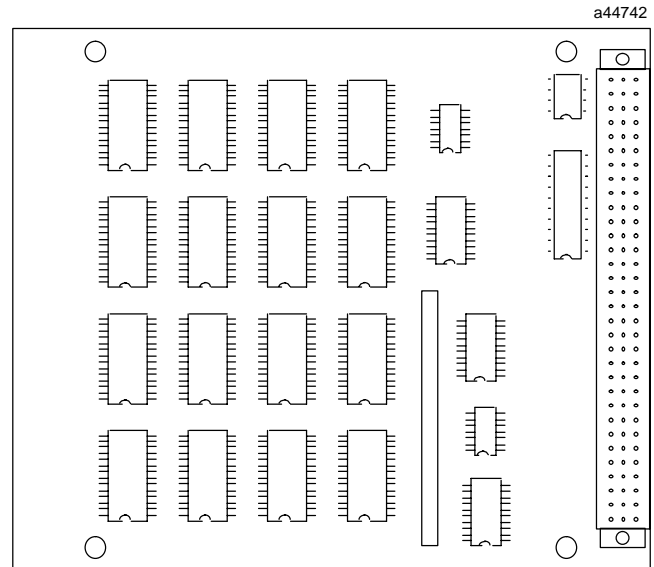

Functions

This CMOS Expansion Memory is available in four versions; 64, 128, 256 and 512 Kbytes. This memory may be used to expand logic and data memory in either the CPU 771 (IC697CPU771) and CPU 772 (IC697CPU772) modules, or the Programmable Co-processor Module (IC697PCM711). It is installed as a daughter board and resides in the same slot as the module it serves. Memory on this board supplements memory available on the base board.

Memory is retained in the event of power loss by the battery on the base board housing.

Logic program memory is continually error-checked by the PLC CPU as a background task.

The PCM error checks storage memory when power is cycled and on hard or soft resets.

Installation

- Installation should not be attempted without referring to the applicable *Programmable Controller Installation Manual* (See reference 4).
- Make sure rack power is off.
- Plug the 64 pin connector into the connector on the base board, and engage snaps.
- Place module in rack.
- Turn power on.

CPU Installation:

- Clear memory using either MS-DOS® or Windows® programming software following instructions in the *Programming Software User's Manual* (See reference 1).

PCM Installation:

- For the PCM follow the instructions in the *Programmable Coprocessor Module Support Software User's Manual* (See reference 3).

Batteries

The Lithium battery (IC697ACC701) is installed as shown in figure 1. This battery maintains user memory when power is removed and operates the calendar clock on the PLC CPU. Be sure to install the new battery before removing the old battery. Specific indication of a low battery state is detailed in References 3 and 4.

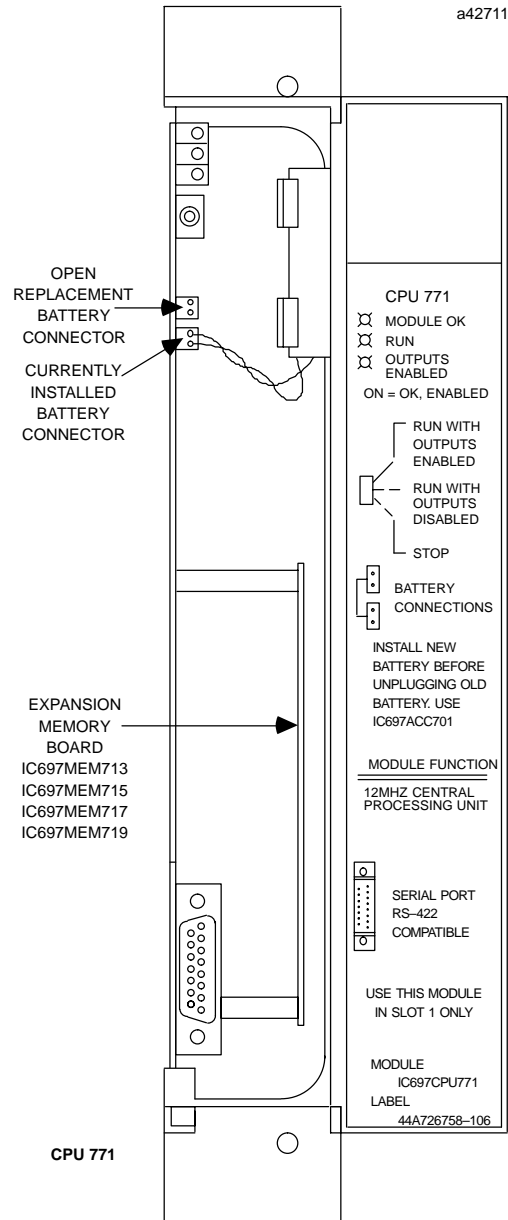

Figure 1. Location of Expansion Memory and Battery on CPU771/772 and PCM

Table 1. References

Reference	Title
1	Programming Software User's Manual
2	Programmable Controller Reference Manual
3	Programmable Coprocessor Module and Support Software User's Manual
4	Programmable Controller Installation Manual

Table 2. Specifications for IC697MEM713/715/717/719 †

Battery	
Shelflife	10 years at 20° C (68° F)
Memory retention	6 months nominal without applied power.
VME	System designed to support the VME standard C.1

† Refer to GFK-0867B, or later for product standards and general specifications.

Table 3. Ordering Information

Description	Catalog Number
64 Kbyte CMOS Expansion Memory	IC697MEM713
128 Kbyte CMOS Expansion Memory	IC697MEM715
256 Kbyte CMOS Expansion Memory	IC697MEM717
512 Kbyte CMOS Expansion Memory	IC697MEM719
Lithium Battery	IC697ACC701

Note: For Conformal Coat option, or Low Temperature Testing option please consult the factory for price and availability.

Expansion Memory

IC697MEM731/732/733/735

GFK-0531E
August 1997

32-Bit CMOS Expansion Memory

Features

- Available in 128 KBytes, 256 KBytes w/256 KBytes non-volatile flash memory, 256 KBytes and 512 Kbytes.
- For expansion of CPU780/781/782/788/789.
- Memory retained by battery on CPU.
- Does not require additional slot.
- Configurable for data and program storage.
- Error checking by CPU checksum routine.
- Installation requires only a #1 Phillips screwdriver.
- Field Installable.
- Parity generation and checking for each byte of SRAM.

Functions

CMOS Expansion Memory is available in four versions; 128 KBytes, 256 KBytes w/256 KBytes non-volatile flash memory, 256 KBytes and 512 Kbytes. This memory must be used to provide logic and data memory in the PLC CPU780/781/782/788/789 Central Processor Unit modules. It is installed as a daughter board and resides in the same slot as the module it serves. This board is required for proper operation of these CPUs since the base board contains no RAM memory.

Memory is retained in the event of power loss by the battery on the base board housing. Flash memory is retained in the event of a power loss *with or without* the battery connected.

Logic program memory is continually error-checked by the PLC CPU as a background task. Memory parity errors are reported to the PLC CPU when they occur.

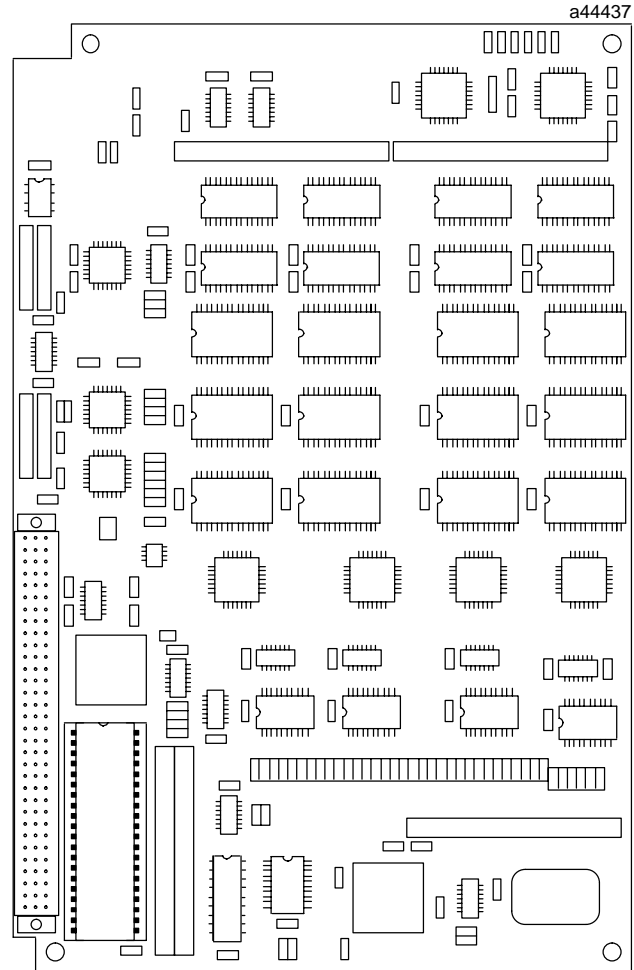

Figure 1. Example of 32-Bit CMOS Expansion Memory Board

GFK-0531E
August 1997

32-Bit CMOS Expansion Memory

Installation

- Installation should not be attempted without referring to the *Programmable Controller Installation Manual* and applicable data sheets (Refer to References 3, 4, 5 and 6).
- Align the expansion memory board and CPU connectors.
- Align the captive screws on the expansion memory board with the standoffs already installed on the CPU.
- Push the expansion memory board onto the CPU connector ensuring that the mating screws remain aligned with their respective standoff.
- Screw each expansion memory board screw into the standoffs with a #1 Phillips screwdriver, firmly tightening each screw.
- Make sure rack power is off before installing the CPU module. Place module in rack.
- Turn power on.
- Clear memory with MS-DOS® or Windows® programming software following instructions in the *Programming Software User's Manual* (Refer to Reference 1).

Batteries

The Lithium battery (IC697ACC701) is installed as shown in Figure 2. This battery maintains user memory when power is removed and operates the calendar clock on the PLC CPU. Be sure to install the new battery before removing the old battery. Specific indication of a low battery state is detailed in References 3, 4 and 5.

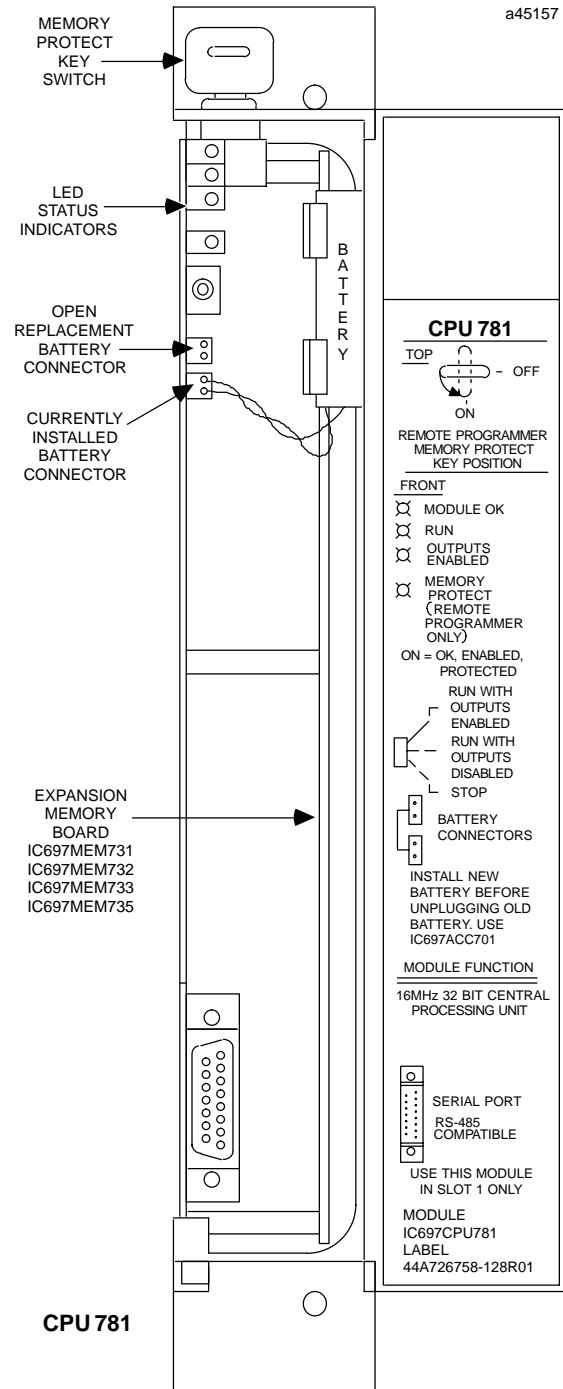

Figure 2. Example of Location of Expansion Memory and Battery on CPU 780/781/782/788/789 (CPU781 Shown)

32-Bit CMOS Expansion Memory

GFK-0531E
August 1997

Table 1. References

Reference	Title
1	ProgrammingSoftware User's Manual
2	ProgrammableLogic Controller Reference Manual
3	ProgrammableController Installation Manual
4	Data Sheet for IC697CPU781, 32-Bit, 16 MHz, Expandable
5	Data Sheet for IC697CPU782, 32-Bit, 16 MHz, Expandable, Floating Point
6	Data Sheet for IC697CPU780, 32-Bit, 16 MHz, Expandable, Floating Point, for Redundancy Applications
7	Data Sheet for IC697CPU788/789 32-Bit, 16 MHz, Expandable for Genius Triple Redundancy Systems

Table 2. Specifications for CMOS Expansion Memory Modules †

Battery Shelflife: Memory retention:	10 years at 20°C (68° F) 6 months nominal without applied power
Current required from 5V bus:	2.25 amps (includes expansion memory board and CPU module)
VME	System designed to support the VME standard C.1

† Refer to GFK-0867B, or later for product standards and general specifications.

Table 3. Ordering Information

Description	Catalog Number
128 KByte, 32-Bit CMOS Expansion Memory	IC697MEM731
256 KByte w/256 KByte Non-Volatile Flash memory, 32-Bit CMOS Expansion Memory	IC697MEM732
256 KByte, 32-Bit CMOS Expansion Memory	IC697MEM733
512 KByte, 32-Bit CMOS Expansion Memory	IC697MEM735
Lithium Battery	IC697ACC701

Note: For Conformal Coat option, or Low Temperature Testing option please consult the factory for price and availability.

Coprocessor Modules

IC697PCM711

GFK-0164G
August 1997

Programmable Coprocessor Module

Features

- Single slot Coprocessor
- Dual Tasking
- MegaBasic™
- CCM2 Protocol
- 12 Mhz, 80C186 microprocessor
- 90% of an IBM® AT performance
- Up to 96 Kbytes battery-backed CMOS logic and data memory on board
- Supports up to 512 Kbytes optional expansion memory
- Programmed by IC647, IC640 or IBM-compatible Personal Computer
- Two RS-422/RS-485 or RS-232 serial ports
- High performance access to PLC memory
- Real time calendar clock synchronized to PLC
- Reset pushbutton
- Three Status LEDs
- Soft Configuration (No dip switches or jumpers) with MS-DOS® or Windows® based programming software configuration function
- Simultaneous communications on both ports at up to 9.6 Kbaud, or up to 19.2 Kbaud individually.

Functions

The Programmable Coprocessor Module (PCM) is a Coprocessor to the PLC CPU. It can be programmed to perform operator interface, real time computations, data storage, data acquisition and data communications functions. It communicates with the PLC CPU over the backplane and can access user and system data using extensions to the powerful MegaBasic language. No application program support is required in the PLC CPU.

Many PCMs can be supported in a single IC697 PLC system and each can accommodate an optional expansion memory up to 512 Kbytes.

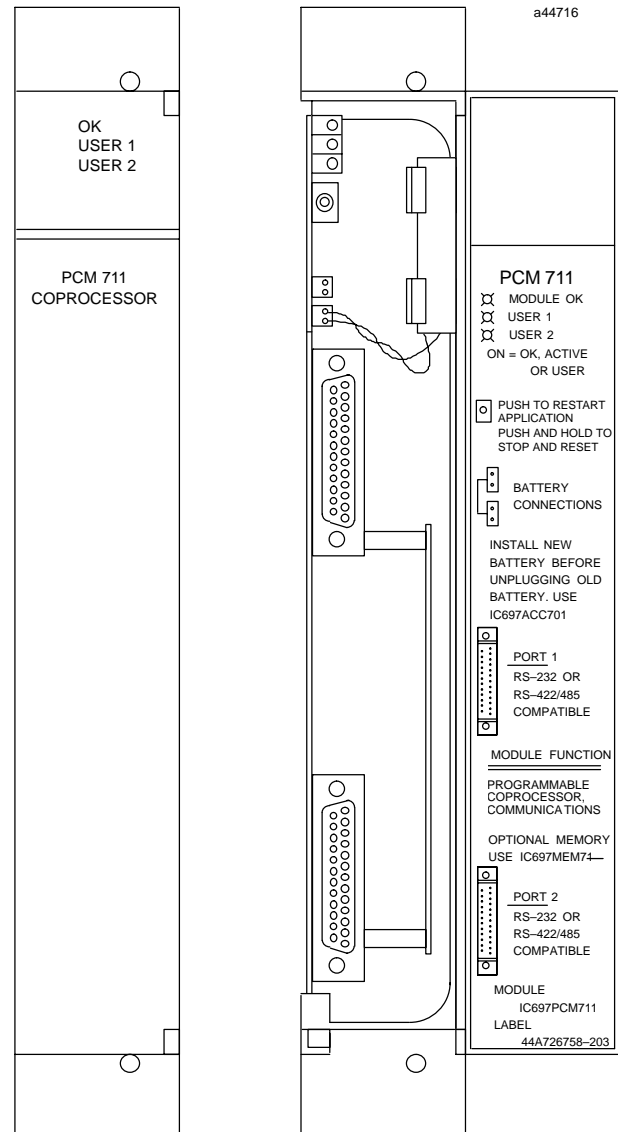

Dual tasking allows running a MegaBasic program at the same time the PCM is used as a communications interface. Operation of the module may be initialized by a pushbutton or by an attached PCM development system. The status of the PCM is indicated by three green LEDs on the front of the module.

™ MegaBasic is a trademark of Christopher Cochran; ©IBM is a registered trademark of International Business Machines Corporation.

© MS-DOS and Windows are registered trademarks of Microsoft Corporation.

GFK-0164G
August 1997

Programmable Coprocessor Module

Installation

- Installation should not be attempted without referring to the applicable *Programmable Controller Installation Manual* (see reference 5).
- Make sure rack power is off.
- Install expansion memory if required.
- Connect the battery to either of the battery connectors on the module. (See figure 2)
- Install in the rack. (See figure 1)
- Turn on power.

The module should power up and blink the top LED. When the diagnostics have completed successfully the top LED stays on.

Expansion Memory

The PCM can operate with or without an expansion memory daughter board. The base memory on the PCM board has up to 95 Kbytes user memory. The expansion memory daughter board permits expansion of program/data memory by 64, 128, 256 or 512 Kbytes. The battery which supports this memory is located on the base board housing as shown in figure 2.

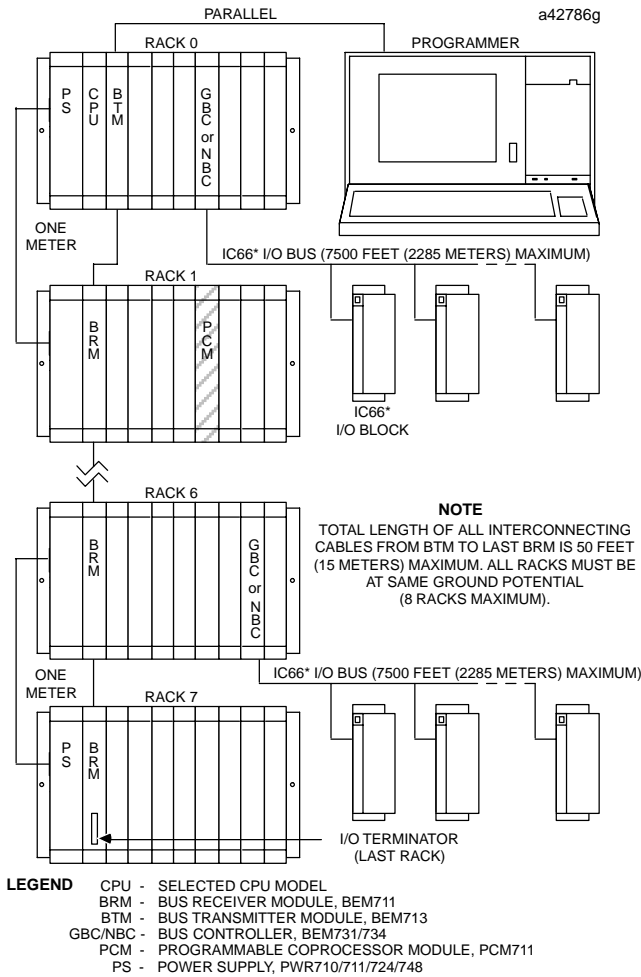

Figure 1. Typical PLC System Configuration (PCM Shown in Rack 1)

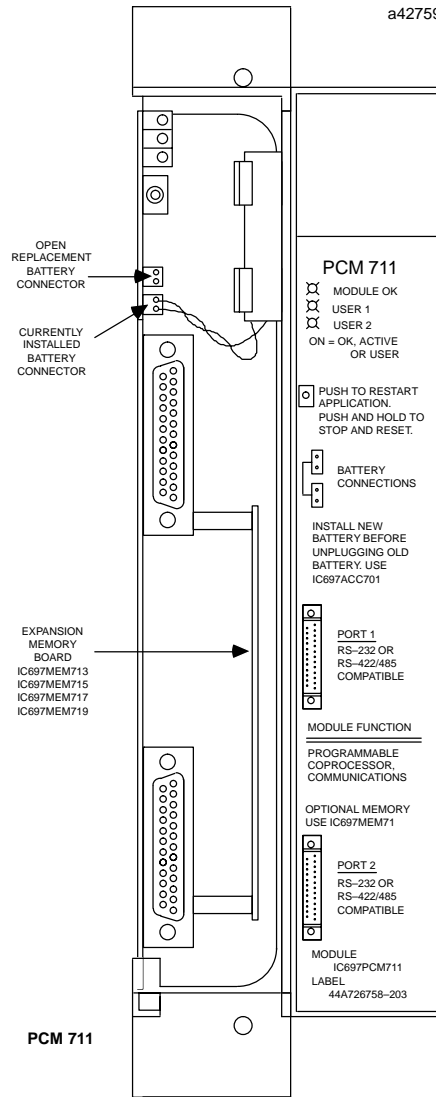

Figure 2. Programmable Coprocessor Module - User Details

Programmable Coprocessor Module

GFK-0164G
August 1997

Programming and Configuration

An IC647 or IC640 computer, or IBM-compatible PC, XT, or AT computer with PCM Development Software installed is connected to the top port of the PCM. The default setting is 19,200 bps. The PCM Development Software is used to configure the serial port parameters, to define the interface to the PLC CPU, to select task functions and to program MegaBasic applications. The PCM parameters can also be configured using MS-DOS® or Windows® programming software. Consult reference 3 for details of operation.

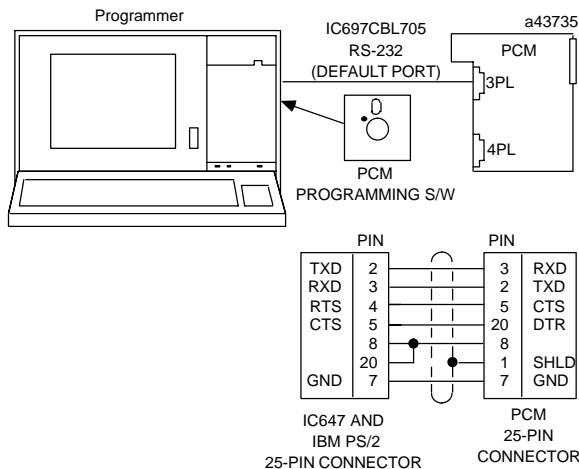

Figure 3. PCM Development System Connection to PCM

Serial Ports

Both ports are RS-232 and RS-422/RS-485 compatible. Both ports acting simultaneously can each support up to 9.6 Kbaud full duplex data communications, or they can support up to 19.2 Kbaud individually.

Port 1 (3PL) and Port 2 (4PL)

Connectors 3PL and 4PL contain signals for both RS-232 and RS-422/RS-485 types of communication circuits. The pin-out for the RS-232 signals are per the RS-232 specification with an exception that pins not normally used for RS-232 are used for RS-422/RS-485 signals. Details are shown in tables 1 and 2.

Table 1. Port 1 or 2 - RS-232

PIN	FUNCTION	SIGNAL NAME	I/O
1	Shield	-	-
2	Transmitted Data	TD	Output
3	Received Data	RD	Input
4	Request To Send	RTS	Output
5	Clear To Send	CTS	Input
7	Signal Ground	0V	-
8	Data Carrier Detect	DCD	Input
20	Data Terminal Ready	DTR	Output

Table 2. Port 1 or 2 - RS-422/RS-485

PIN	FUNCTION	SIGNAL NAME	I/O
9	Send Data (A)	SD (A)	Output
10	Request to Send (A)	RTS (A)	Output
11	Clear to Send (A)	CTS (A)	Input
12	Termination for pin 13	-	-
13	Receive Data (A)	RD (A)	Input
21	Send Data (B)	SD (B)	Output
22	Request to Send (B)	RST (B)	Output
23	Clear to Send (B)	CTS (B)	Input
24	Termination for pin 23	-	-
25	Receive Data (B)	RD (B)	Input

Configuration

There are no user DIP switches or jumpers on this board for configuration. However, the board must be configured before operation using PCM Development Software (See reference 3).

Status Indication

Three Status LEDs are available as shown in Figure 2. The top LED indicates the condition of the module, the bottom two LEDs may be assigned to a configured function.

Controls

One pushbutton is provided. Push and hold for less than 5 seconds will restart an application. Push and hold for more than 5 seconds and the module factory default configuration will be installed (this action will not clear memory but will permit communication with the programmer using factory default settings).

GFK-0164G
August 1997

Programmable Coprocessor Module

Batteries

A lithium battery (IC697ACC701) is installed as shown in figure 2. This battery maintains user memory when power is removed. Be sure to install the new battery before removing the old battery.

If during power-up diagnostics a low battery is detected the Module OK LED (top) will not stay on. Specific indication of a low battery state is detailed in the *PCM Support Software User's Manual*.

Table 3. References

Reference	Title
1	ProgramingSoftware User 's Manual
2	ProgrammableControllerReference Manual
3	PCM Support Software User 's Manual
4	MegaBasicProgramming Language Reference Manual
5	ProgrammableControllerInstallationManual

Table 4. Specifications for IC697PCM711 †

Battery	
Shelf life	10 years at 20°C (68°F)
Memory retention	6 months nominal without applied power.
Current required from 5V bus	1.0 amp
Serial Ports	RS-232/RS-422/RS-485 compatible
VME	System designed to support the VME standard C.1

† Refer to GFK-0867B, or later for product standards and general specifications. If the PLC installation must comply with supported standards, such as FCC or CE Directives, please refer to the *Installation Requirements for Conformance to Standards*, shipped with the PLC programming software, for additional guidelines.

Table 5. Ordering Information

Description	Catalog Number
PCM, 12 Mhz, 20 Kbyte, Expandable	IC697PCM711
64 Kbyte CMOS Expansion Memory	IC697MEM713
128 Kbyte CMOS Expansion Memory	IC697MEM715
256 Kbyte CMOS Expansion Memory	IC697MEM717
512 Kbyte CMOS Expansion Memory	IC697MEM719
Lithium Battery	IC697ACC701

Note: For Conformal Coat option, or Low Temperature Testing option please consult the factory for price and availability.

Coprocessor Modules

IC697ADC701

GFK-0521E
August 1997

Alphanumeric Display Coprocessor (ADC)

Features

- Single slot Alphanumeric Display Coprocessor
- Runs Alphanumeric Display System software
- 12 Mhz, 80C186 microprocessor
- High performance access to PLC memory
- Reset pushbutton; three status LEDs
- Soft Configuration (No DIP switches or jumpers) with MS-DOS® or Windows® based programming software configuration function
- Easy fill-in-the-blank system building
- Pop-up windows; pull down menus
- 15 User definable function keys per screen
- Printer logging to a serial printer

Functions

The Alphanumeric Display Coprocessor Module is a coprocessor to the IC697 PLC CPU. It is programmed to perform Alphanumeric Display System display, report, and alarm functions through an Operator Interface Terminal, which can be an OIT or Mini OIT, a VT100 compatible terminal, or an IC647 industrial computer or IBM® compatible personal computer running TERME. It communicates with the IC697 CPU over the system backplane.

Up to 63 Alphanumeric Display Coprocessors can be supported in a single IC697 PLC system and can be located in either the main rack or expansion racks.

Operation of the module may be initialized by depressing a pushbutton on the module or by an attached ADS (PCOP) development system. The status of the ADC is indicated by three green LEDs on the front of the module.

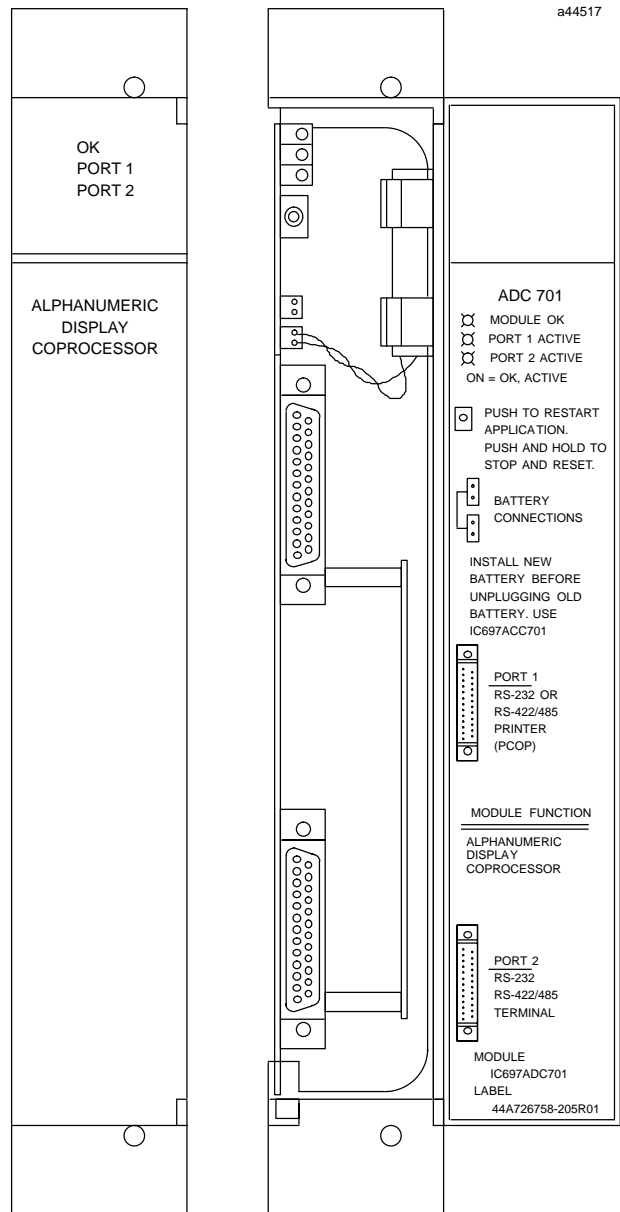

® IBM and PS/2 are registered trademarks of International Business Machines Corporation.
® MS-DOS and Windows are registered trademarks of Microsoft Corporation.

GFK-0521E
August 1997

Alphanumeric Display Coprocessor (ADC)

Installation

- Installation should not be attempted without referring to the applicable *Programmable Controller Installation Manual*, the *ADS User's Manual*, and the *ADS Reference Manual*.
- Make sure rack power is off before installing the Alphanumeric Display Coprocessor module.
- Connect the battery to either of the battery connectors on the module (see figure 2).
- Install in the rack (see figure 1).
- Turn on power.

The module should power-up and blink the top LED. When the diagnostics have completed successfully the top LED stays on.

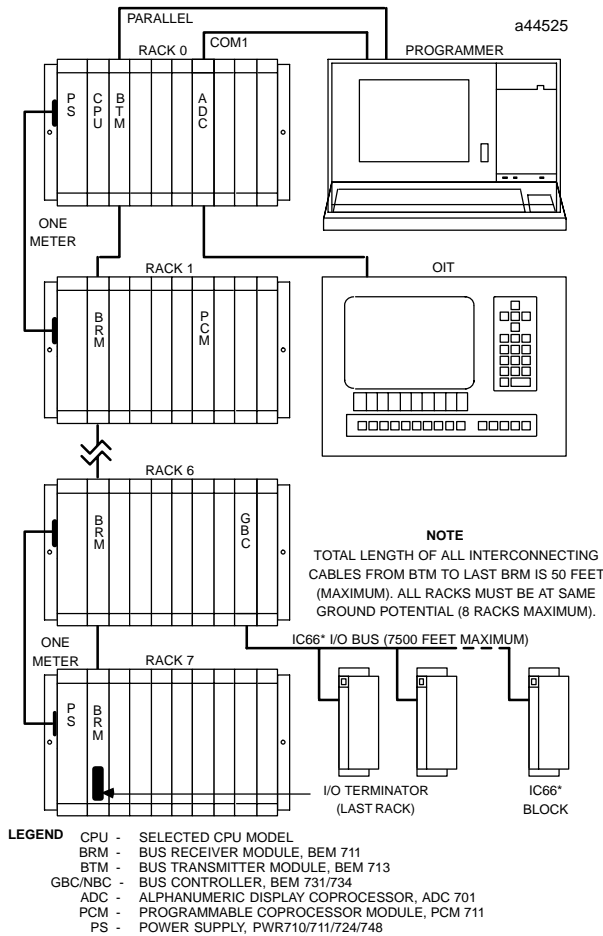

Figure 1. Typical PLC System Configuration

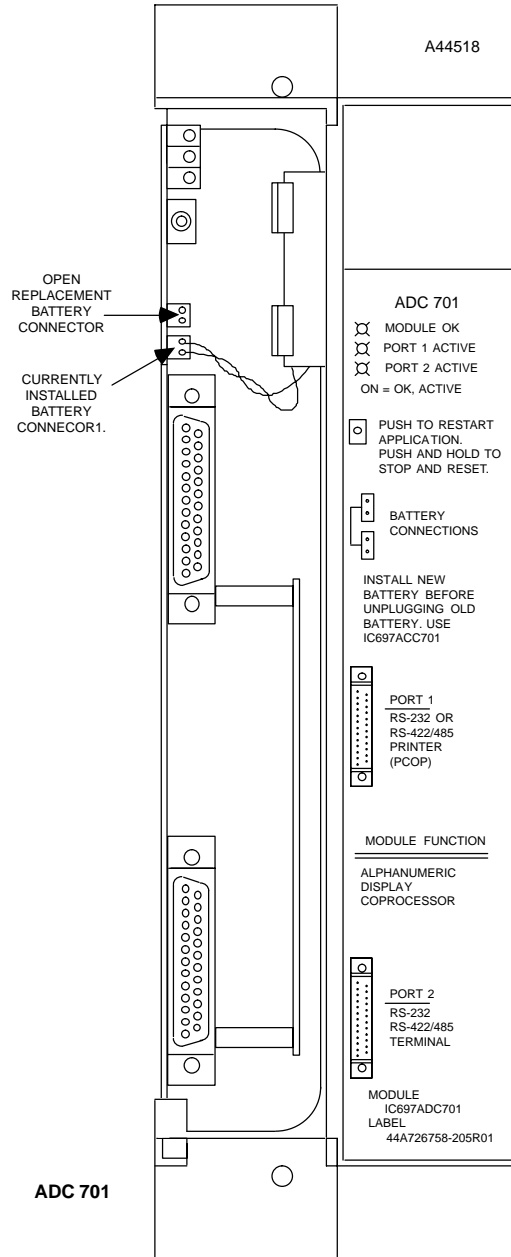

Figure 2. Alphanumeric Display Coprocessor Module - User Details

Alphanumeric Display Coprocessor (ADC)

GFK-0521E
August 1997

Programming and Configuration

An IC647, IC640, or an IBM-compatible PC, XT, AT, or PS/2 computer with PCM Development Software (PCOP) installed connects to the top port as shown in figure 3. The default setting is 19,200 bps. The PCM Development Software is used to configure the serial port parameters and to install the Alphanumeric Display System software onto the ADC. Refer to the the *ADS User's Manual*, for details of operation.

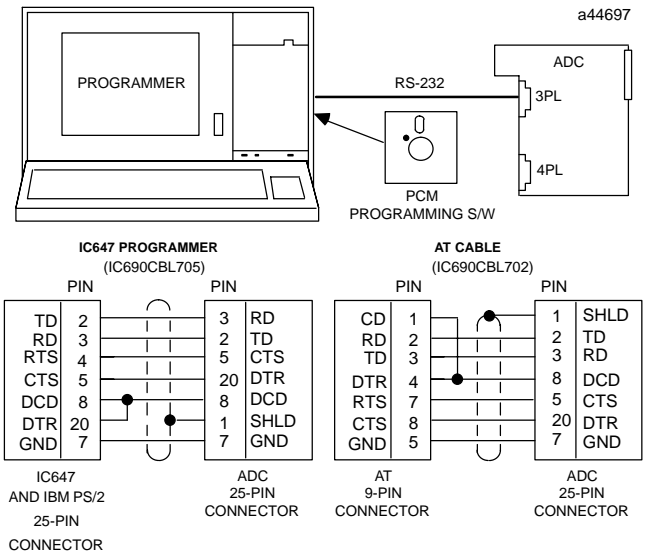

Figure 3. Example of PCM Development System Connection to ADC

Serial Ports

Although both ports are RS-232 and RS-422/RS-485 compatible and the signals shown in both Table 1 and Table 2 are available at each connector, the use of each port is dedicated for ADC operation.

Port 1 (3PL) and Port 2 (4PL)

Port 1 (3PL) is normally connected to an RS-232 serial COM port of a host computer for communications to PCOP at 19.2 Kilobaud. Alternately, port 1 may be connected to a serial RS-232 printer (see the *Alphanumeric Display System User's Manual* to reconfigure Port 1). Figure 3 shows typical cable connections for this purpose and Table 1 shows the details of the RS-232 signals.

Table 1. Port 1 and 2 – RS-232 Signals

PIN	FUNCTION	SIGNAL NAME	I/O
1	Shield	-	-
2	Transmitted Data	TD	Output
3	Received Data	RD	Input
4	Request To Send	RTS	Output
5	Clear To Send	CTS	Input
7	Signal Ground	GND	-
8	Data Carrier Detect	DCD	Input
20	Data Terminal Ready	DTR	Output

Port 2 (4PL) is configured as a 19.2 Kbaud RS-232 port and interfaces to the OIT or other terminal's RS-232 port for keyboard input and screen output. Figure 4 shows appropriate cable connections and Table 2 shows usable RS-422 signal details.

Table 2. Port 1 and 2 – RS-422/485 Signals

PIN	FUNCTION	SIGNAL NAME ⁶	I/O
7	Signal Ground	SG	-
9	Send Data (A)	SD (A)	Output
10	Request To Send (A)	RTS (A)	Output
11	Clear To Send (A)	CTS (A)	Input
12	Termination for pin 11	-	-
13	Receive Data (A)	RD (A)	Input
21	Send Data (B)	SD (B)	Output
22	Request To Send (B)	RTS (B)	Output
23	Clear To Send (B)	CTS (B)	Input
24	Termination for pin 25	-	-
25	Receive Data (B)	RD (B)	Input

GFK-0521E
August 1997

Alphanumeric Display Coprocessor (ADC)

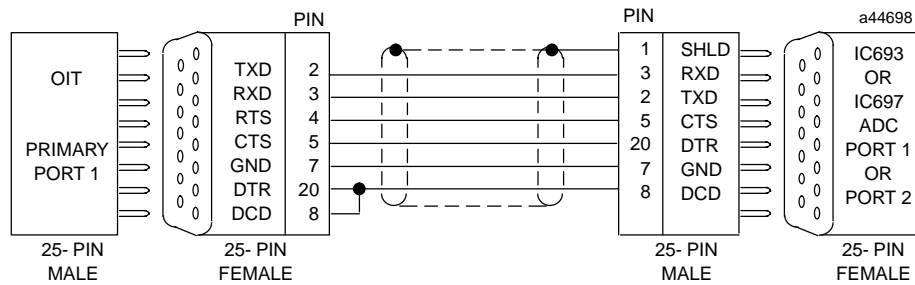

Figure 4. ADC Port 2 Connection to an OIT

Configuration

There are no user DIP switches or jumpers on this board for configuration. However, the Alphanumeric Display System software must be loaded using PCM Development Software (refer to the *Alphanumeric Display System User's Manual* for details). The ADC must be configured with the MS-DOS or Windows based programming software configuration function prior to use.

Status Indication

Three Status LEDs are available as shown in figure 2. The top LED indicates the condition of the ADC module, the bottom two LEDs indicate serial port activity.

Controls

One pushbutton is provided. Push and hold for less than 5 seconds will restart the Alphanumeric Display System software. Push and hold for more than 5 seconds and the module factory default configuration will be installed (this action will not clear memory but will permit communications with the programmer using factory default settings).

Batteries

A lithium battery (IC697ACC701) is installed as shown in figure 2. This battery maintains user memory when power is removed. Be sure to install the new battery in the unused battery connector before removing and discarding the old battery. If during power-up diagnostics a low battery is detected, the Module OK LED (top) will not stay on.

Table 3. References

Reference	Title
1	ProgrammingSoftware User's Manual
2	ProgrammableControllerReferenceManual
3	Programmable Coprocessor Module and Support Software User's Manual
4	ProgrammableControllerInstallationManual
5	AlphanumericDisplaySystemUser's Manual
6	AlphanumericDisplaySystemReference Manual
7	Operator Interface Terminal User's Manual
8	Mini Operator Interface Terminal User's Manual
9	IC600 Operator Interface Terminal User's Manual

Alphanumeric Display Coprocessor (ADC)

GFK-0521E
August 1997

Table 4. Specifications for IC697ADC701 †

Battery	
Shelflife	10 years at 20°C (68°F)
Memory retention	6 months nominal without applied power.
Current Required from 5V Bus	1.0 amp
Serial Ports	RS-232andRS-422/RS-485compatible
VME	System designed to support the VME standard C.1

† Refer to GFK-0867B, or later for product standards and general specifications. If the PLC installation must comply with supported standards, such as FCC or CE Directives, please refer to the *Installation Requirements for Conformance to Standards*, shipped with the PLC programming software, for additional guidelines.

Table 5. Ordering Information

Description	Catalog Number
AlphanumericDisplay Coprocessor Module	IC697ADC701
LithiumBattery	IC697ACC701

Note: For Conformal Coat option, or Low Temperature Testing option please consult the factory for price and availability.

Discrete Input Modules

IC697MDL252

GFK-0756D

August 1997

12 Volt AC, 32-Point Input Module

Features

- 32 Points - Four isolated groups of 8 points each
- 20 ms input filter
- Proximity switch compatible

Functions

The **12 volt AC Input** module provides 32 input points in four isolated groups of eight points each. This allows each group of eight points to be used on a different phase of the AC supply.

The input is resistive with current-voltage characteristics which meet IEC standard (type 1). The input characteristics are compatible with a large range of available proximity switches.

LED indicators which give the ON-OFF status of each point on the logic (PLC) side of the circuit are included at the top of the module.

The module is mechanically keyed to ensure correct replacement with a similar type in the field. I/O references are user configurable without the use of jumpers or DIP switches on the module.

Configuration is done using the configuration function of the MS-DOS® or Windows programming software running on Windows® 95 or Windows NT® over Ethernet TCP/IP or through the SNP port. The Programming Software configuration function is installed on the programming device. The programming device can be an IBM® XT, AT/PS/2® or compatible Personal Computer.

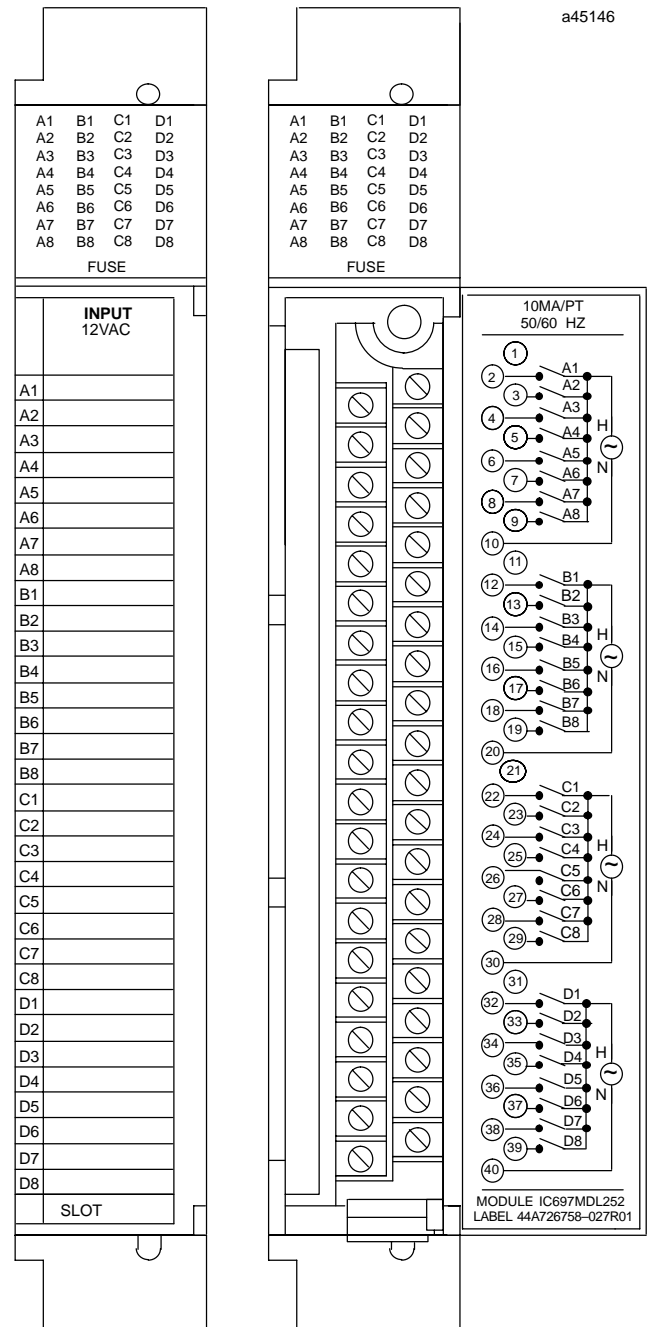

© IBM and PS/2 are registered trademarks of International Business Machines Corporation.

© MS-DOS, Windows, Windows 95, and Windows NT are registered trademarks of Microsoft Corporation.

Operation of the 12 VOLT AC Input Module

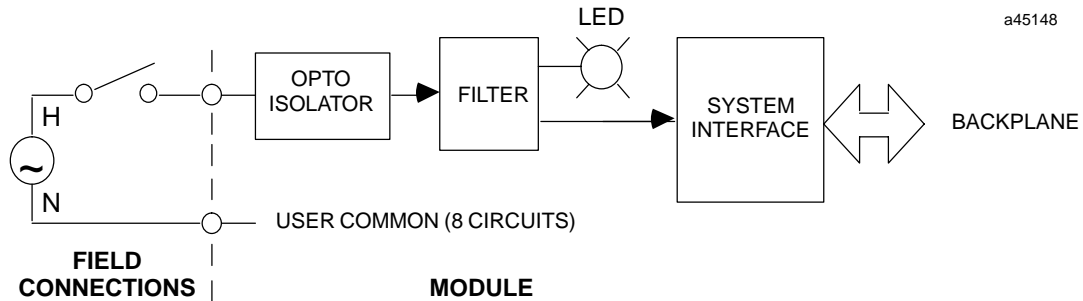

Figure 1. Block Diagram for IC697MDL252

Input Characteristics

The 12 Volt AC Input Module is compatible with a wide variety of input devices, such as:

- Pushbuttons, limit switches, selector switches
- Electronic proximity switches, both 2-wire and 3-wire

The input circuitry provides sufficient current to ensure reliable operation of the switching device. Input current is typically 10mA in the ON state, and can accept up to 2 mA leakage current in the OFF state without turning on.

Three-wire proximity switches are easily applied, since they provide low voltage drop in the ON state and low leakage current in the OFF State.

Two-wire proximity switches derive their power from the signal connections; thus both the ON state voltage and the OFF state leakage current are higher than for 3-wire devices. This module is designed to be compatible with many of these two-wire devices; however each device type must be carefully evaluated for compatibility in both the ON and OFF states.

To determine compatibility with a specific proximity switch, find the ON state characteristics of the switch in the diagram shown below in Figure 2. If that point falls to the left of the input load line, the ON state characteristics are compatible. As an example, the ON state requirements of a compatible proximity switch of 3mA at 5 volts drop are shown below.

OFF state compatibility is assured if the proximity switch leakage is less than 2mA with a module input voltage of 2.5 volts or less.

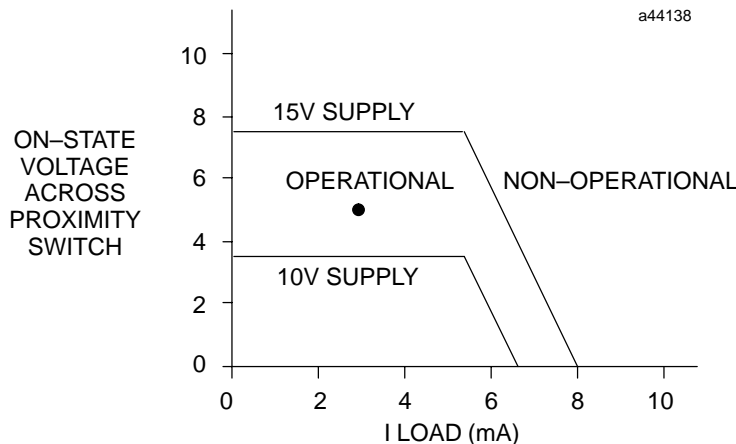

Figure 2. Proximity Switch Compatibility

12 Volt AC, 32-Point Input Module

GFK-0756D
August 1997

Module Power

The 12 Volt AC Input Module requires 0.30 amps from the 5 volt bus on the backplane.

Module Mechanical Keying

This module includes a mechanical key that prevents inadvertent substitution of one module type for another in a given slot. The key fits a uniquely shaped area on the board below the connector. The key is included with each module.

When the module is first installed, the key latches onto the backplane center rail. When the module is extracted, the key remains in the center rail, configuring the slot to accept only identical module types.

If it is necessary to change the module location in the rack after the key has been latched onto the center rail of the rack, the key can be removed by pushing it upward to unhook the latch while pulling it off the rail. It may then be reinserted onto the module and the module inserted into the rack in the desired location. Note that only the power supply can be placed in the leftmost rack position.

Field Wiring

The module is wired as shown in the illustration on the right of this page. Since each group of eight inputs is isolated from the others, a wire from the power source to the power input terminal for each group (terminal number 10, 20, 30, or 40) is required (power input terminals for each group are not connected inside the module).

The detachable field wiring terminal board will accept wire sizes from #22 (0.36 mm²) through #14 (2.10 mm²). Two wires may be terminated on a given lug if both wires are the same size. There is room for a bundle of forty #14 (2.10 mm²)wires to be routed out through the terminal board cavity.

The wire bundle can be secured to the terminal board by passing a cable tie through a cleat located at the lower corner of the terminal board.

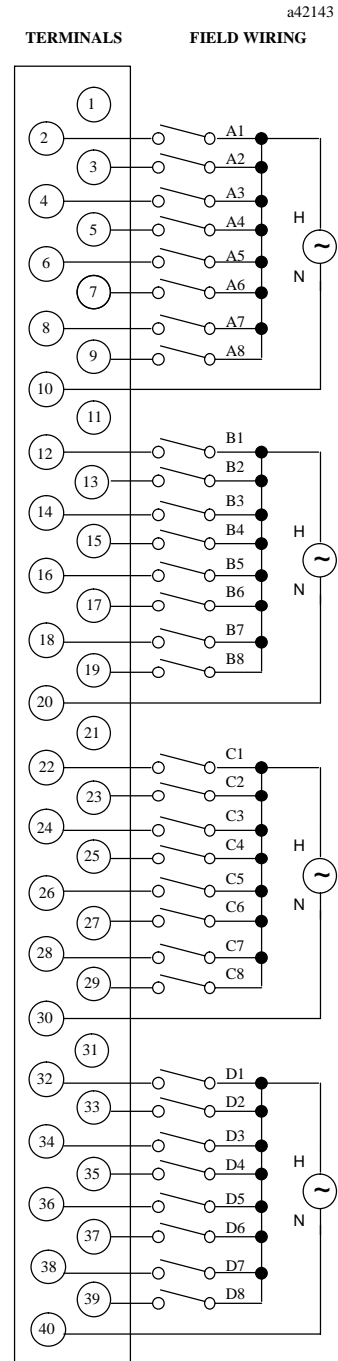

Figure 3. Field Wiring Connections

GFK-0756D
August 1997

12 Volt AC, 32-Point Input Module

Recommended Field Wiring Procedures

The following procedures are recommended when connecting field wiring to the detachable terminal board on this input

module. Module features referenced in the following procedures which are common to all I/O modules for the IC697 PLC are illustrated in the following figure.

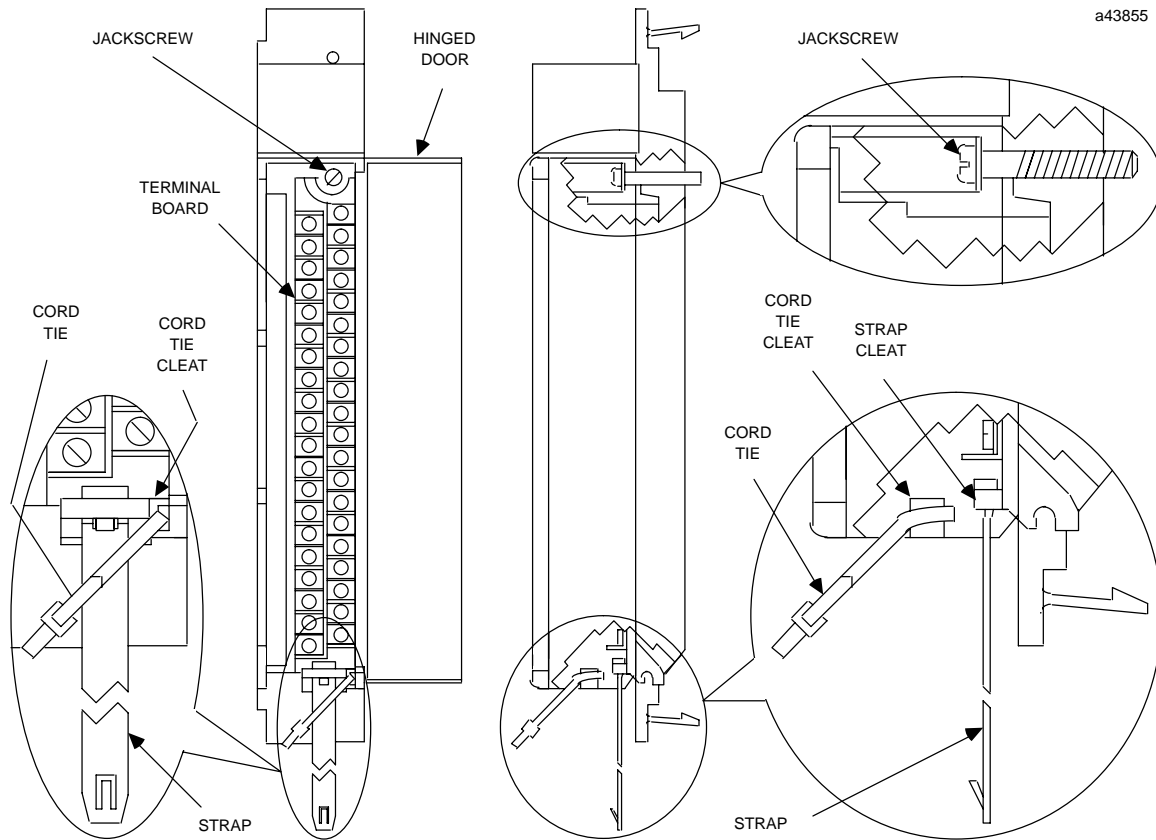

Figure 4. I/O Module Features

1. Turn off power before removing or installing terminal boards. Open the hinged door on the module to access a jackscrew which holds the terminal board securely in place. The Detachable field wiring terminal board can now be removed from the module by turning the jackscrew counter-clockwise until it is fully disengaged.
2. To remove the terminal board, grasp the top of the terminal board and swing it outward as shown in Figure 5.
3. The terminal board is designed to accept wire sizes from AWG #22 (0.36 mm^2) through AWG #14 (2.10 mm^2). It is important that when using AWG #14 wire for wiring all points, that a maximum insulation diameter of .135 inch (3.43 mm) not be exceeded. To ensure proper connection, two wires may be terminated on any one terminal only if both wires are the same size.
4. The terminal board is designed to accept a maximum of (40) AWG #14 (2.10 mm^2) wires. If AWG #14 (2.10 mm^2) wires are to be used, then wire markers should be placed at least 8 inches (203 mm) from termination end to provide sufficient space for the hinged door to close.

Caution

Do not use the hinged door to remove the terminal board. The hinged door could be damaged if this is done.

12 Volt AC, 32-Point Input Module

GFK-0756D
August 1997

Figure 5. Removal of I/O Terminal Board

5. After completing connections to all modules in a rack, the wire bundle must be secured. To ensure that the wire bundle is secured properly, it is recommended that a cable tie be wrapped around the wire bundle and tightly secured through the cable tie cleat located at the lower right corner of the terminal board. For extremely large wire bundles, additional cable ties should be used.
6. A door label insert is included with each module to indicate circuit wiring information and provide space to record user circuit wiring identification. A slot is provided on the hinged door to allow for insertion of this label. If the label is difficult to insert, crease the scored edge before insertion. The outside label has a color coded stripe to allow quick identification of the module voltage type (blue: low voltage; red: high voltage).
7. After field wiring is completed, the terminal board should be securely fastened to the rack by inserting the terminal board strap (attached to each module) into the small rectangular slots in the bottom card guide grill on the rack. This strap not

only secures the terminal board to the rack, it also provides a way of identifying the wired terminal board with its correct mating rack slot location.

8. For adequate module ventilation, it is recommended that at least a 6 inch (152 mm) clearance be allowed above and below the rack grill. Wire bundles should not obstruct the rack grill work.

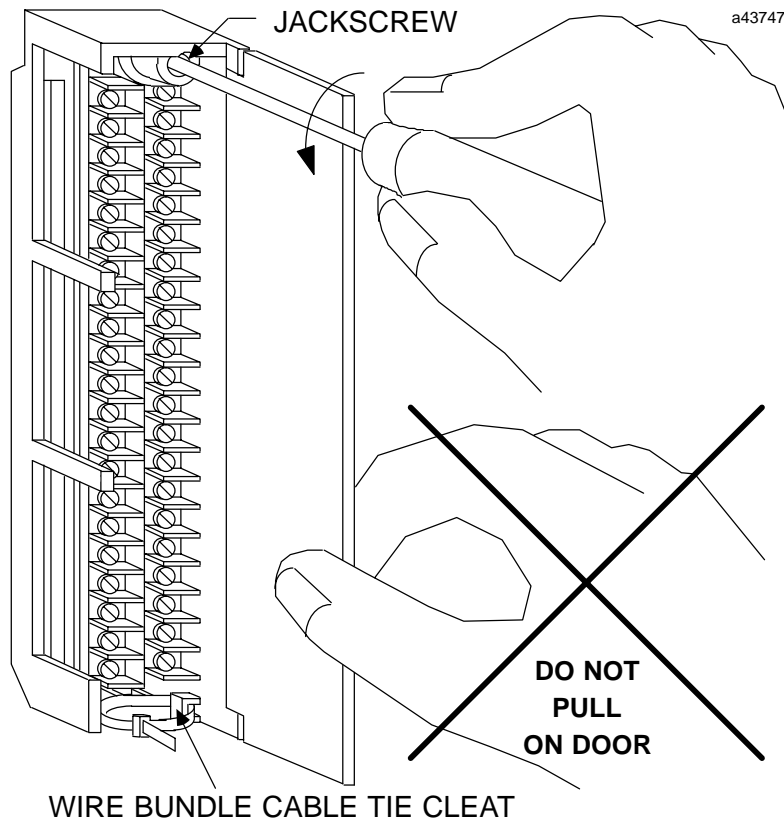
Removing an I/O Module

The instructions below should be followed when removing an I/O module from its slot in a rack.

1. Grasp the board firmly at the top and bottom of the board cover with your thumbs on the front of the cover and your fingers on the plastic clips on the back of the cover.
2. Squeeze the rack clips on the back of the cover with your fingers to disengage the clip from the rack rail and pull the board firmly to remove it from the backplane connector.
3. Slide the board along the card guide and remove it from the rack.

GFK-0756D
August 1997

12 Volt AC, 32-Point Input Module

Table 1. Specifications for IC697MDL252 †

Rated Voltage:	12 VAC, 47 to 63 Hz Sinusoidal
Inputs per Module:	32 (four groups of eight inputs each)
Isolation:	1500 volts RMS - any input to backplane 500 volts RMS between input groups
Input Current: Input Impedance: Input Characteristics-	10mA (typical) at rated voltage 1.12K ohm typical
On-state Voltage:	7.5 to 15 volts RMS, 47 to 63 Hz Sinusoidal
Off-state Voltage:	0 to 2.5 volts RMS, 47 to 63 Hz Sinusoidal
On-state Current:	6mA to 15mA
Off-state Current:	0 to 2.5mA (2mA minimum at 2.5V input)
Filter Delay Time:	20mstypical
Current Required from 5VDC backplane bus:	0.3 amps
VME	System designed to support the VME standard C.1

† Refer to GFK-0867B, or later for product standards and general specifications. For installations requiring compliance to more stringent requirements (for example, FCC or European Union Directives), refer to *Installation Requirements for Conformance to Standards*.

Table 2. Ordering Information

Description	Catalog Number
Input Module : 12 Volt AC, 32 Points	IC697MDL252

Note: For Conformal Coat option, or Low Temperature Testing option please consult the factory for price and availability.

Discrete Input Modules

IC697MDL253

GFK-0757C
August 1997

24 Volt AC, 32-Point Input Module

Features

- 32 Points - Four isolated groups of 8 points each
- 20 ms input filter
- Proximity switch compatible

Functions

The **24 volt AC Input** module provides 32 input points in four isolated groups of eight points each. This allows each group of eight points to be used on a different phase of the AC supply.

The input is resistive with current-voltage characteristics which meet IEC standard (type 1). The input characteristics are compatible with a large range of available proximity switches.

LED indicators which give the ON-OFF status of each point on the logic (PLC) side of the circuit are included at the top of the module.

The module is mechanically keyed to ensure correct replacement with a similar type in the field. I/O references are user configurable without the use of jumpers or DIP switches on the module.

Configuration is done using the configuration function of the MS-DOS® or Windows programming software running on Windows® 95 or Windows NT® over Ethernet TCP/IP or through the SNP port. The Programming Software configuration function is installed on the programming device. The programming device can be an IBM® XT, AT/PS/2® or compatible Personal Computer.

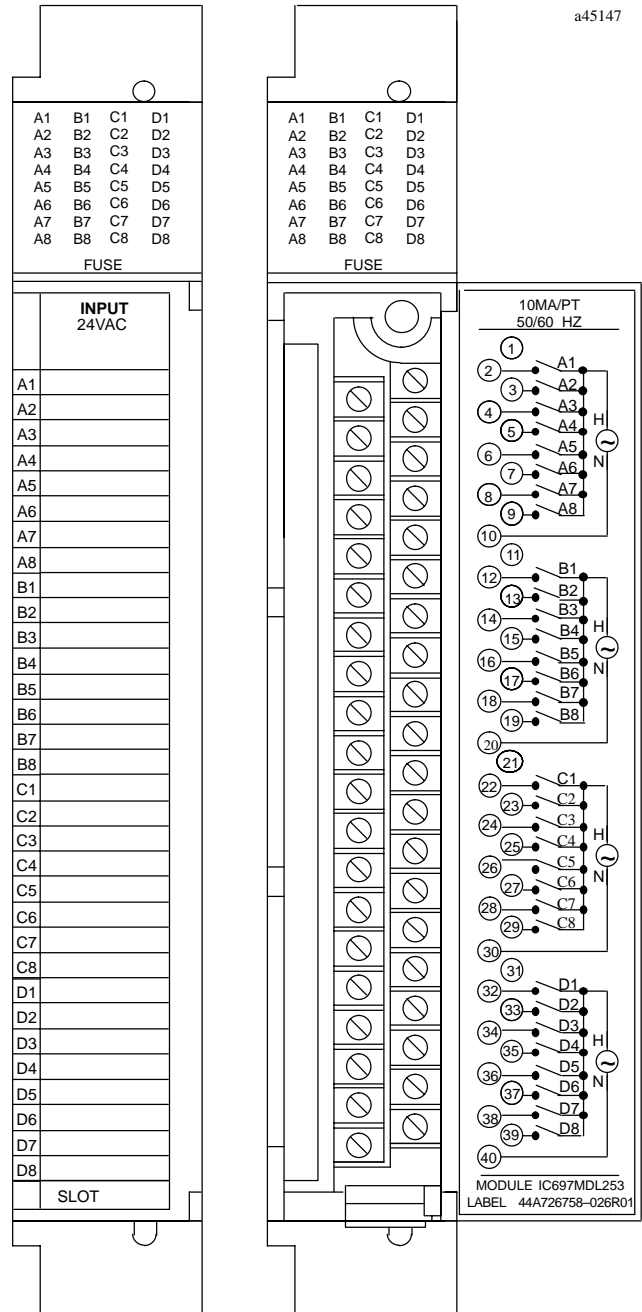

© IBM and PS/2 are registered trademarks of International Business Machines Corporation.

© MS-DOS, Windows, Windows 95, and Windows NT are registered trademarks of Microsoft Corporation.

Operation of the 24 VOLT AC Input Module

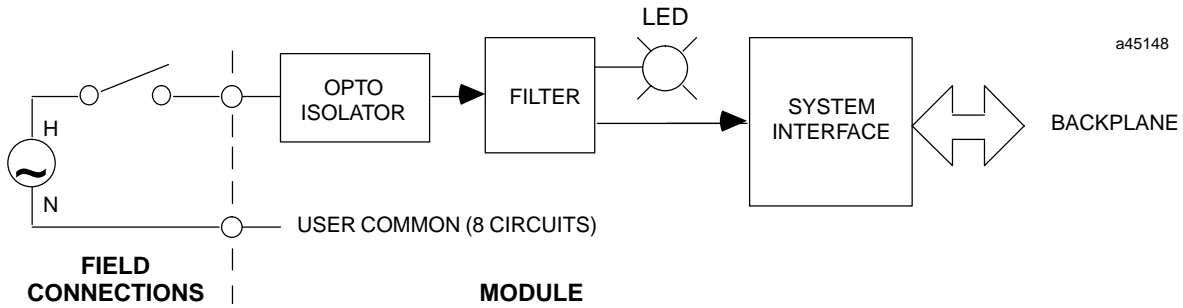

Figure 1. Block Diagram for IC697MDL253

Input Characteristics

The 24 Volt AC Input Module is compatible with a wide variety of input devices, such as:

- Pushbuttons, limit switches, selector switches
- Electronic proximity switches, both 2-wire and 3-wire

The input circuitry provides sufficient current to ensure reliable operation of the switching device. Input current is typically 10mA in the ON state, and can accept up to 2 mA leakage current in the OFF state without turning on.

Three-wire proximity switches are easily applied, since they provide low voltage drop in the ON state and low leakage current in the OFF State.

Two-wire proximity switches derive their power from the signal connections; thus both the ON state voltage and the OFF state leakage current are higher than for 3-wire devices. This module is designed to be compatible with many such two-wire devices; however each device type must be carefully evaluated for compatibility in both the ON and OFF states.

To determine compatibility with a specific proximity switch, find the ON state characteristics of the switch in the diagram shown below in Figure 2. If that point falls to the left of the input load line, the ON state characteristics are compatible. As an example, the ON state requirements of a compatible proximity switch of 3mA at 5 volts drop are shown below.

OFF state compatibility is assured if the proximity switch leakage is less than 2mA with a module input voltage of 5 volts or less.

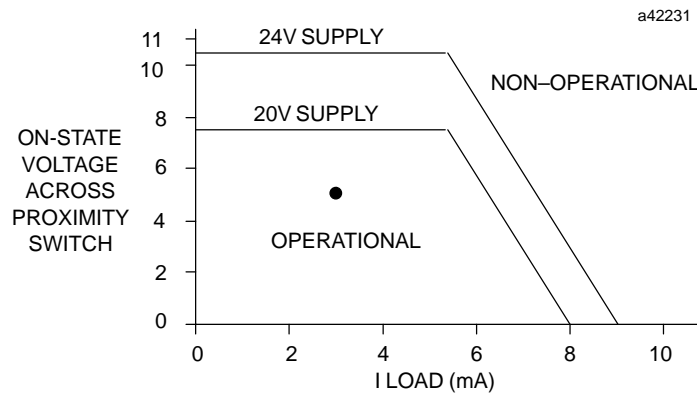

Figure 2. Proximity Switch Compatibility

24 Volt AC, 32-Point Input Module

GFK-0757C
August 1997

Module Power

The 24 Volt AC Input Module requires 0.30 amps from the 5 volt bus on the backplane.

Module Mechanical Keying

This module includes a mechanical key that prevents inadvertent substitution of one module type for another in a given slot. The key fits a uniquely shaped area on the board below the connector. The key is included with each module.

When the module is first installed, the key latches onto the backplane center rail. When the module is extracted, the key remains in the center rail, configuring the slot to accept only identical module types.

If it is necessary to change the module location in the rack after the key has been latched onto the center rail of the rack, the key can be removed by pushing it upward to unhook the latch while pulling it off the rail. It may then be reinserted onto the module and the module inserted into the rack in the desired location. Note that only the power supply can be placed in the leftmost rack position.

Field Wiring

The module is wired as shown in the illustration on the right of this page. Since each group of eight inputs is isolated from the others, a wire from the power source to the power input terminal for each group (terminal number 10, 20, 30, or 40) is required (power input terminals for each group are not connected inside the module).

The detachable field wiring terminal board will accept wire sizes from #22 (0.36 mm²) through #14 (2.10 mm²). Two wires may be terminated on a given lug if both wires are the same size. There is room for a bundle of forty #14 (2.10 mm²) wires to be routed out through the terminal board cavity.

The wire bundle can be secured to the terminal board by passing a cable tie through a cleat located at the lower corner of the terminal board.

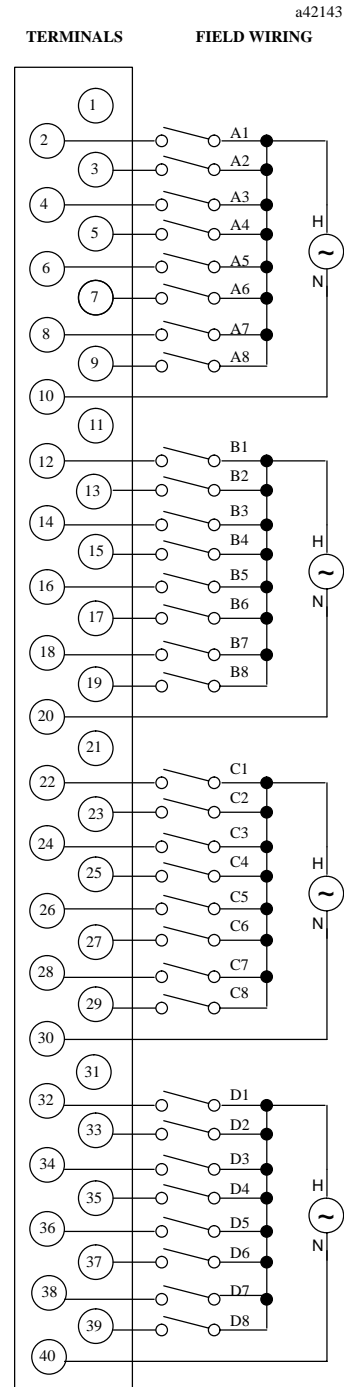

Figure 3. Field Wiring Connections

GFK-0757C
August 1997

24 Volt AC, 32-Point Input Module

Recommended Field Wiring Procedures

The following procedures are recommended when connecting field wiring to the detachable terminal board on this input

module. Module features referenced in the following procedures which are common to all I/O modules for the IC697 PLC are illustrated in the following figure.

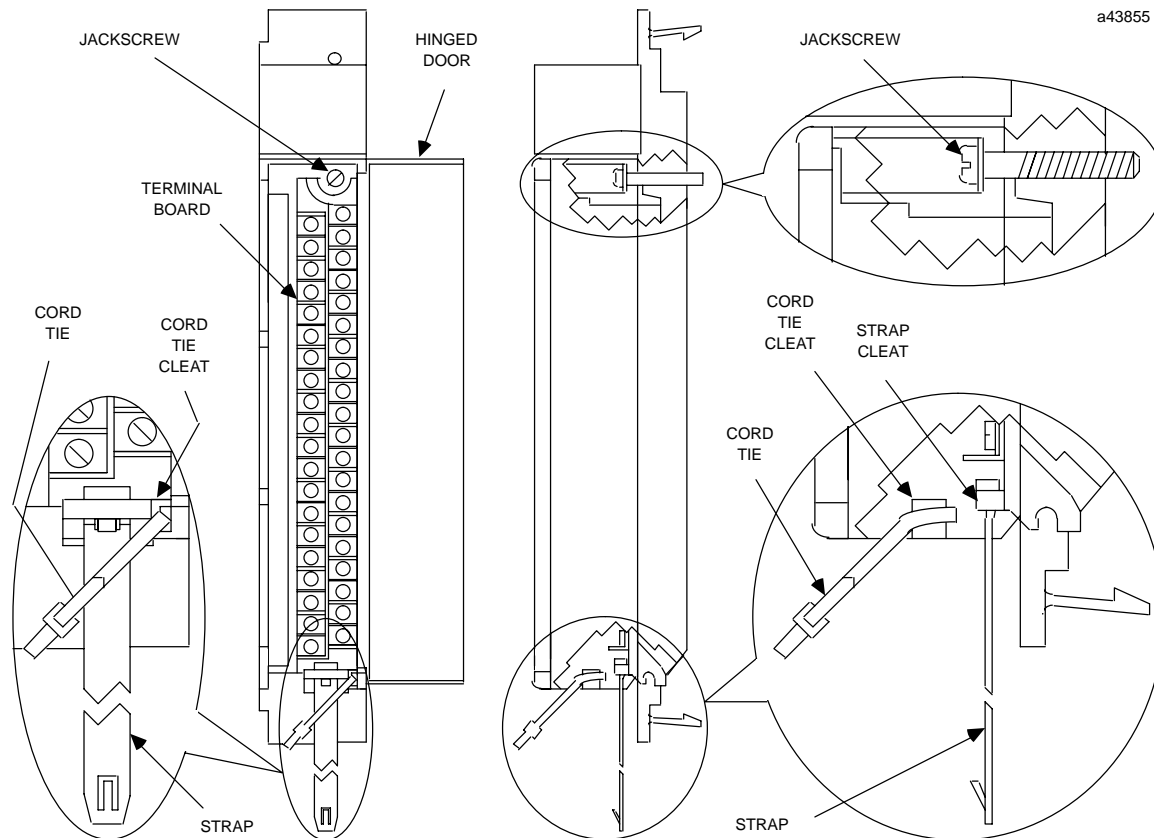

Figure 4. I/O Module Features

1. Turn off power before removing or installing terminal boards. Open the hinged door on the module to access a jackscrew which holds the terminal board securely in place. The Detachable field wiring terminal board can now be removed from the module by turning the jackscrew counter-clockwise until it is fully disengaged.
2. To remove the terminal board, grasp the top of the terminal board and swing it outward as shown in Figure 5.
3. The terminal board is designed to accept wire sizes from AWG #22 (0.36 mm^2) through AWG #14 (2.10 mm^2). It is important that when using AWG #14 (2.10 mm^2) wire for wiring all points, that a maximum insulation diameter of .135 inch (3.43 mm) not be exceeded. To ensure proper connection, two wires may be terminated on any one terminal only if both wires are the same size.
4. The terminal board is designed to accept a maximum of (40) AWG #14 (2.10 mm^2) wires. If AWG #14 (2.10 mm^2) wires are to be used, then wire markers should be placed at least 8 inches (203 mm) from termination end to provide sufficient space for the hinged door to close.

Caution

Do not use the hinged door to remove the terminal board. The hinged door could be damaged if this is done.

24 Volt AC, 32-Point Input Module

GFK-0757C
August 1997

Figure 5. Removal of I/O Terminal Board

5. After completing connections to all modules in a rack, the wire bundle must be secured. To ensure that the wire bundle is secured properly, it is recommended that a cable tie be wrapped around the wire bundle and tightly secured through the cable tie cleat located at the lower right corner of the terminal board. For extremely large wire bundles, additional cable ties should be used.
6. A door label insert is included with each module to indicate circuit wiring information and provide space to record user circuit wiring identification. A slot is provided on the hinged door to allow for insertion of this label. If the label is difficult to insert, crease the scored edge before insertion. The outside label has a color coded stripe to allow quick identification of the module voltage type (blue: low voltage; red: high voltage).
7. After field wiring is completed, the terminal board should be securely fastened to the rack by inserting the terminal board strap (attached to each module) into the small rectangular slots in the bottom card guide grill on the rack. This strap not

only secures the terminal board to the rack, it also provides a way of identifying the wired terminal board with its correct mating rack slot location.

8. For adequate module ventilation, it is recommended that at least a 6 inch (152 mm) clearance be allowed above and below the rack grill. Wire bundles should not obstruct the rack grill work.

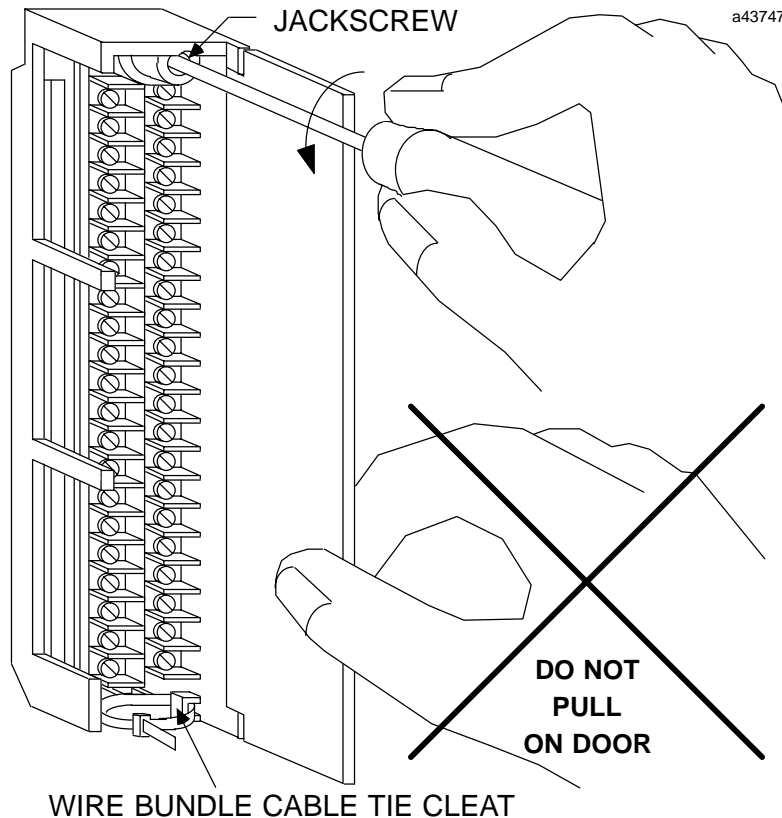
Removing an I/O Module

The instructions below should be followed when removing an I/O module from its slot in a rack.

1. Grasp the board firmly at the top and bottom of the board cover with your thumbs on the front of the cover and your fingers on the plastic clips on the back of the cover.
2. Squeeze the rack clips on the back of the cover with your fingers to disengage the clip from the rack rail and pull the board firmly to remove it from the backplane connector.
3. Slide the board along the card guide and remove it from the rack.

GFK-0757C
August 1997

24 Volt AC, 32-Point Input Module

Table 1. Specifications for IC697MDL253 †

Rated Voltage:	24 VAC, 47 to 63 Hz Sinusoidal
Inputs per Module:	32 (four groups of eight inputs each)
Isolation:	1500 volts RMS - any input to backplane 500 volts RMS between input groups
Input Current: Input Impedance: Input Characteristics -	10mA (typical) at rated voltage 2.6K ohms typical
On-state Voltage:	13.5 to 30 volts RMS, 47 to 63 Hz Sinusoidal
Off-state Voltage:	0 to 5 volts RMS, 47 to 63 Hz Sinusoidal
On-state Current:	6mA to 15mA
Off-state Current:	0 to 2mA (2mA minimum at 5V input)
Filter Delay Time:	20ms typical
Current Required from 5VDC backplane bus:	0.3 amps
VME	System designed to support the VME standard C.1

† Refer to GFK-0867B, or later for product standards and general specifications. For installations requiring compliance to more stringent requirements (for example, FCC or European Union Directives), refer to *Installation Requirements for Conformance to Standards*.

Table 2. Ordering Information

Description	Catalog Number
Input Module - 24 Volts AC, 32 Points	IC697MDL253

Note: For Conformal Coat option, or Low Temperature Testing option please consult the factory for price and availability.

Discrete Input Modules

IC697MDL254

GFK-0784C
August 1997

48 Volt AC, 32-Point Input Module

Features

- 32 Points - Four isolated groups of 8 points each
- 20 ms input filter
- Proximity switch compatible

Functions

The **48 volt AC Input** module provides 32 input points in four isolated groups of eight points each. This allows each group of eight points to be used on a different phase of the AC supply.

The input is resistive with current-voltage characteristics which meet IEC standard (type 1). The input characteristics are compatible with a large range of available proximity switches.

LED indicators which give the ON-OFF status of each point on the logic (PLC) side of the circuit are included at the top of the module.

The module is mechanically keyed to ensure correct replacement with a similar type in the field. I/O references are user configurable without the use of jumpers or DIP switches on the module.

Configuration is done using the configuration function of the MS-DOS® or Windows programming software running on Windows® 95 or Windows NT® over Ethernet TCP/IP or through the SNP port. The Programming Software configuration function is installed on the programming device. The programming device can be an IBM® XT, AT/PS/2® or compatible Personal Computer.

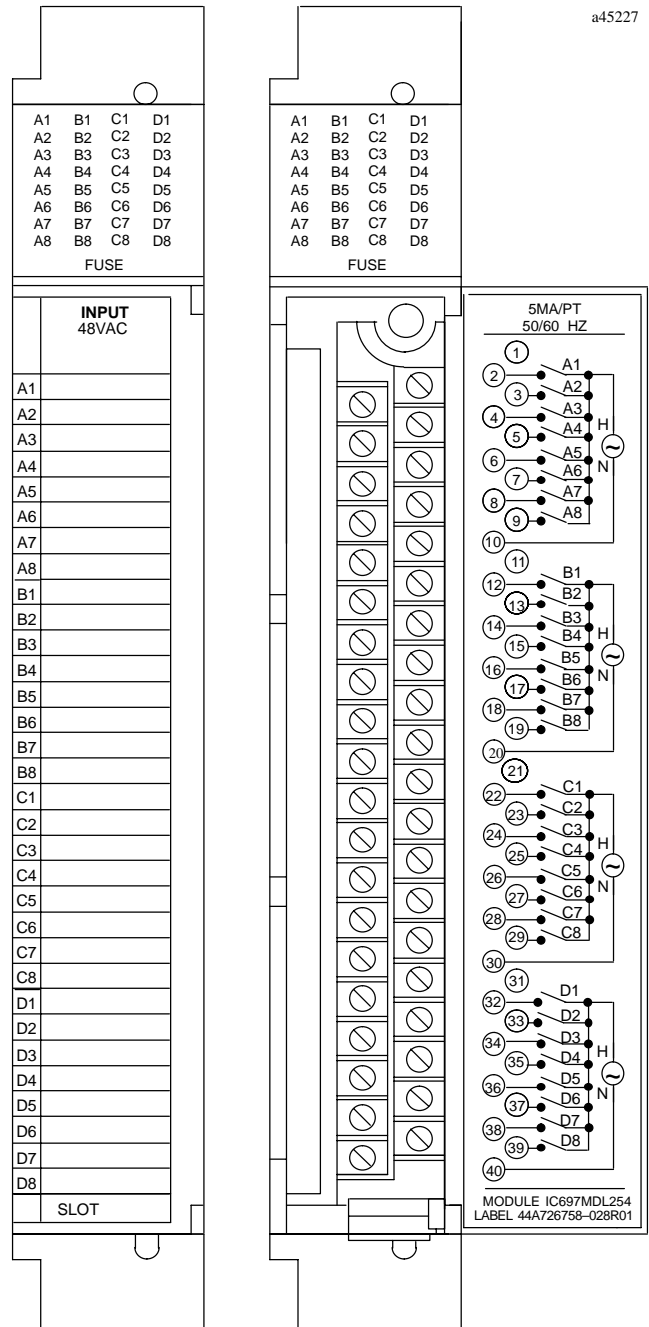

© IBM and PS/2 are registered trademarks of International Business Machines Corporation.

© MS-DOS, Windows, Windows 95, and Windows NT are registered trademarks of Microsoft Corporation.

Operation of the 48 VOLT AC Input Module

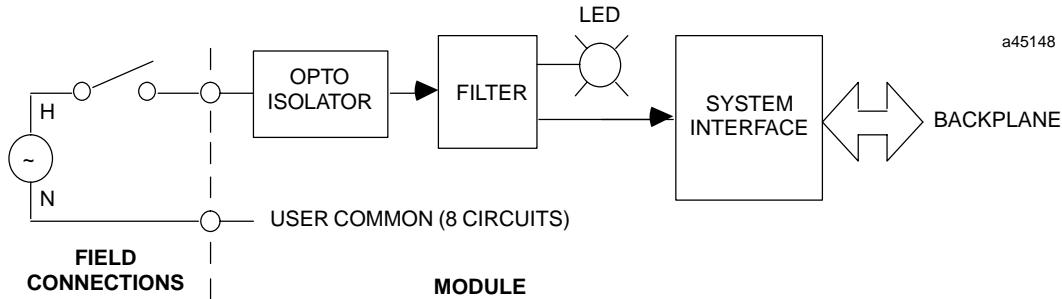

Figure 1. Block Diagram for IC697MDL254

Input Characteristics

The 48 Volt AC Input Module is compatible with a wide variety of input devices, such as:

- Pushbuttons, limit switches, selector switches
- Electronic proximity switches, both 2-wire and 3-wire

The input circuitry provides sufficient current to ensure reliable operation of the switching device. Input current is typically 10mA in the ON state, and can accept up to 2 mA leakage current in the OFF state without turning on.

Three-wire proximity switches are easily applied, since they provide low voltage drop in the ON state and low leakage current in the OFF State.

Two-wire proximity switches derive their power from the signal connections; thus both the ON state voltage and the OFF state leakage current are higher than for three-wire devices. This module is designed to be compatible with many such two-wire devices; however each device type must be carefully evaluated for compatibility in both the ON and OFF states.

To determine compatibility with a specific proximity switch, find the ON state characteristics of the switch in the diagram shown below in Figure 2. If that point falls to the left of the input load line, the ON state characteristics are compatible. As an example, the ON state requirements of a compatible proximity switch of 3mA at 5 volts drop are shown below. OFF state compatibility is assured if the proximity switch leakage is less than 2mA with a module input voltage of 2.5 volts or less.

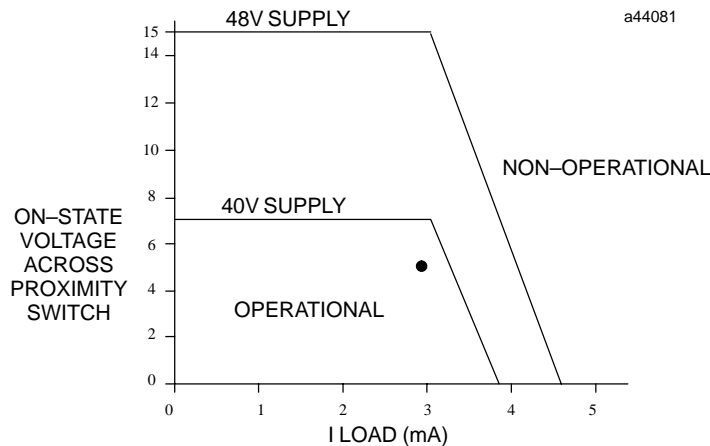

Figure 2. Proximity Switch Compatibility

48 Volt AC, 32-Point Input Module

GFK-0784C
August 1997

Module Power

The 48 Volt AC Input Module requires 0.30 amps from the 5 volt bus on the backplane.

Module Mechanical Keying

This module includes a mechanical key that prevents inadvertent substitution of one module type for another in a given slot. The key fits a uniquely shaped area on the board below the connector. The key is included with each module.

When the module is first installed, the key latches onto the backplane center rail. When the module is extracted, the key remains in the center rail, configuring the slot to accept only identical module types.

If it is necessary to change the module location in the rack after the key has been latched onto the center rail of the rack, the key can be removed by pushing it upward to unhook the latch while pulling it off the rail. It may then be reinserted onto the module and the module inserted into the rack in the desired location. Note that only the power supply can be placed in the leftmost rack position.

Field Wiring

The module is wired as shown in the illustration on the right of this page. Since each group of eight inputs is isolated from the others, a wire from the power source to the power input terminal for each group (terminal number 10, 20, 30, or 40) is required (power input terminals for each group are not connected inside the module).

The detachable field wiring terminal board will accept wire sizes from #22 (0.36 mm²) through #14 (2.10 mm²). Two wires may be terminated on a given lug if both wires are the same size. There is room for a bundle of forty #14 (2.10 mm²) wires to be routed out through the terminal board cavity.

The wire bundle can be secured to the terminal board by passing a cable tie through a cleat located at the lower corner of the terminal board.

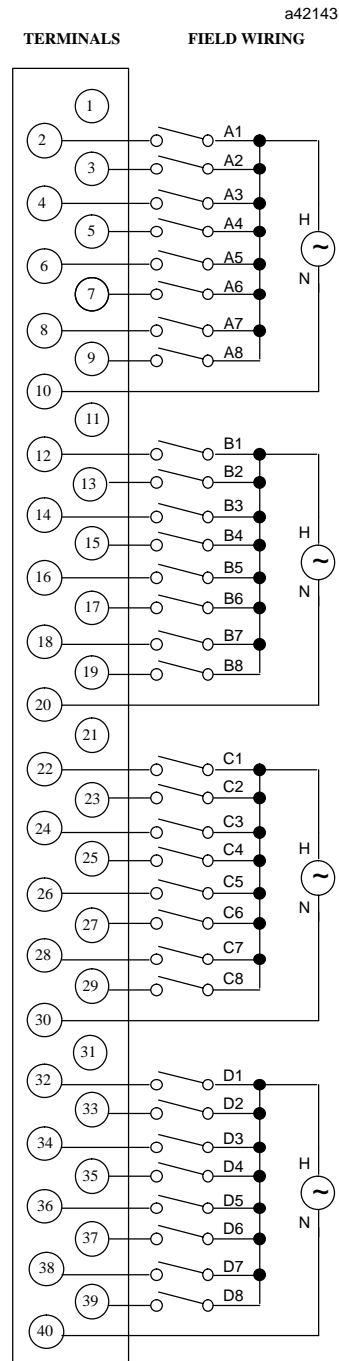

Figure 3. Field Wiring Connections

GFK-0784C
August 1997

48 Volt AC, 32-Point Input Module

Recommended Field Wiring Procedures

The following procedures are recommended when connecting field wiring to the detachable terminal board on this input

module. Module features referenced in the following procedures which are common to all I/O modules for the IC697 PLC are illustrated in the following figure.

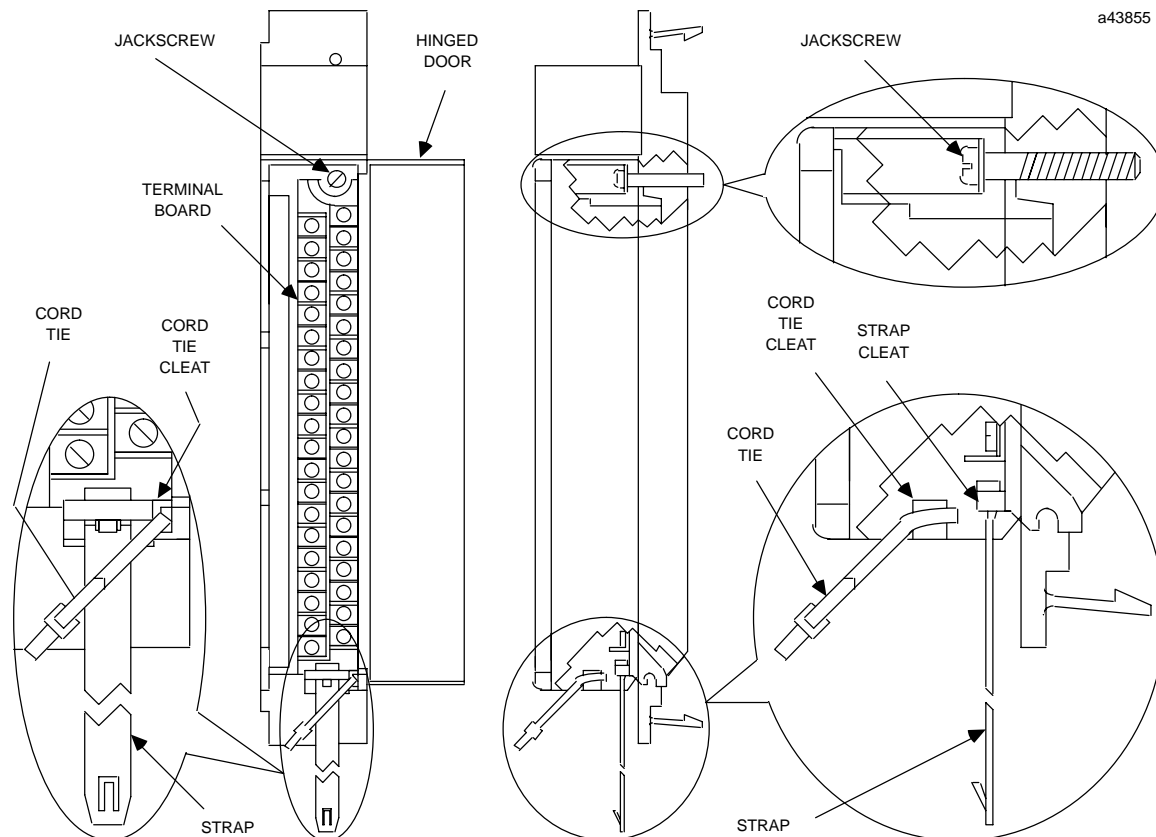

Figure 4. I/O Module Features

1. Turn off power before removing or installing terminal boards. Open the hinged door on the module to access a jackscrew which holds the terminal board securely in place. The Detachable field wiring terminal board can now be removed from the module by turning the jackscrew counter-clockwise until it is fully disengaged.
2. To remove the terminal board, grasp the top of the terminal board and swing it outward as shown in Figure 5.
3. The terminal board is designed to accept wire sizes from AWG #22 (0.36 mm^2) through AWG #14 (2.10 mm^2). It is important that when using AWG #14 (2.10 mm^2) wire for wiring all points, that a maximum insulation diameter of .135 inch (3.43 mm) not be exceeded. To ensure proper connection, two wires may be terminated on any one terminal only if both wires are the same size.
4. The terminal board is designed to accept a maximum of (40) AWG #14 (2.10 mm^2) wires. If AWG #14 (2.10 mm^2) wires are to be used, then wire markers should be placed at least 8 inches (203 mm) from termination end to provide sufficient space for the hinged door to close.

Caution

Do not use the hinged door to remove the terminal board. The hinged door could be damaged if this is done.

48 Volt AC, 32-Point Input Module

GFK-0784C
August 1997

Figure 5. Removal of I/O Terminal Board

5. After completing connections to all modules in a rack, the wire bundle must be secured. To ensure that the wire bundle is secured properly, it is recommended that a cable tie be wrapped around the wire bundle and tightly secured through the cable tie cleat located at the lower right corner of the terminal board. For extremely large wire bundles, additional cable ties should be used.
6. A door label insert is included with each module to indicate circuit wiring information and provide space to record user circuit wiring identification. A slot is provided on the hinged door to allow for insertion of this label. If the label is difficult to insert, crease the scored edge before insertion. The outside label has a color coded stripe to allow quick identification of the module voltage type (blue: low voltage; red: high voltage).
7. After field wiring is completed, the terminal board should be securely fastened to the rack by inserting the terminal board strap (attached to each module) into the small rectangular slots in the bottom card guide grill on the rack. This strap not

only secures the terminal board to the rack, it also provides a way of identifying the wired terminal board with its correct mating rack slot location.

8. For adequate module ventilation, it is recommended that at least a 6 inch (152 mm) clearance be allowed above and below the rack grill. Wire bundles should not obstruct the rack grill work.

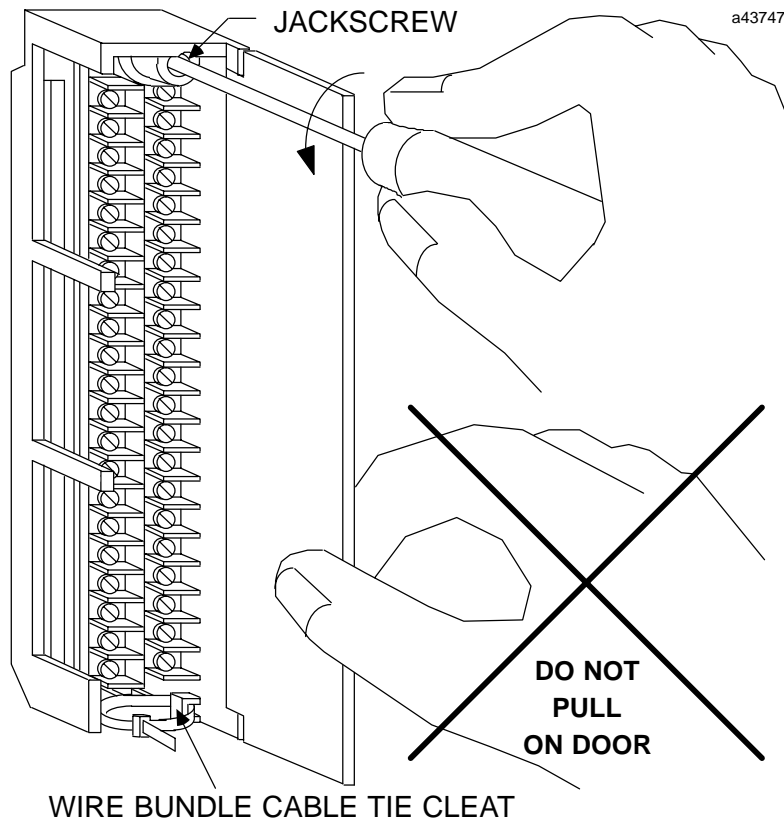
Removing an I/O Module

The instructions below should be followed when removing an I/O module from its slot in a rack.

1. Grasp the board firmly at the top and bottom of the board cover with your thumbs on the front of the cover and your fingers on the plastic clips on the back of the cover.
2. Squeeze the rack clips on the back of the cover with your fingers to disengage the clip from the rack rail and pull the board firmly to remove it from the backplane connector.
3. Slide the board along the card guide and remove it from the rack.

GFK-0784C
August 1997

48 Volt AC, 32-Point Input Module

Table 1. Specifications for IC697MDL254 †

Rated Voltage:	48 VAC, 47 to 63 Hz Sinusoidal
Inputs per Module:	32 (four groups of eight inputs each)
Isolation:	1500 volts RMS - any input to backplane 500 volts RMS between input groups
Input Current: Input Impedance: Input Characteristics -	4.7mA (typical) at rated voltage 10.3K ohm typical
On-state Voltage:	33 to 56 volts RMS, 47 to 63 Hz Sinusoidal
Off-state Voltage:	0 to 10 volts RMS, 47 to 63 Hz Sinusoidal
On-state Current:	3mA to 7mA
Off-state Current:	0 to 2mA (2mA minimum at 5V input)
Filter Delay Time:	20m typical
Current Required from 5VDC backplane bus:	0.3 amps
VME	System designed to support the VME standard C.1

† Refer to GFK-0867B, or later for product standards and general specifications. For installations requiring compliance to more stringent requirements (for example, FCC or European Union Directives), refer to *Installation Requirements for Conformance to Standards*.

Table 2. Ordering Information

Description	Catalog Number
Input Module: 48 Volt AC, 32 Points	IC697MDL254

Note: For Conformal Coat option, or Low Temperature Testing option please consult the factory for price and availability.

Discrete Input Modules

IC697MDL250

GFK-0084J
August 1997

120 Volt AC, 32-Point Input Module

Features

- 32 Points - Four isolated groups of 8 points each
- 20 ms input filter
- Proximity switch compatible

Functions

The **120 volt AC Input** module for the programmable controller provides 32 input points in four isolated groups of eight points each. This allows each group of eight points to be used on a different phase of the AC supply.

The input is reactive (resistor/capacitor input) with current-voltage characteristics which meet IEC standard (type 2). The input characteristics are compatible with a large range of available proximity switches.

LED indicators which give the ON-OFF status of each point on the logic (PLC) side of the circuit are included at the top of the module.

The module is mechanically keyed to ensure correct replacement with a similar type in the field. I/O references are user configurable without the use of jumpers or DIP switches on the module.

Configuration is done using the configuration function of the MS-DOS® or Windows® programming software running on Windows® 95 or Windows NT® over Ethernet TCP/IP or through the SNP port. The Programming Software configuration function is installed on the programming device. The programming device can be an IBM® XT, AT/PS/2® or compatible Personal Computer.

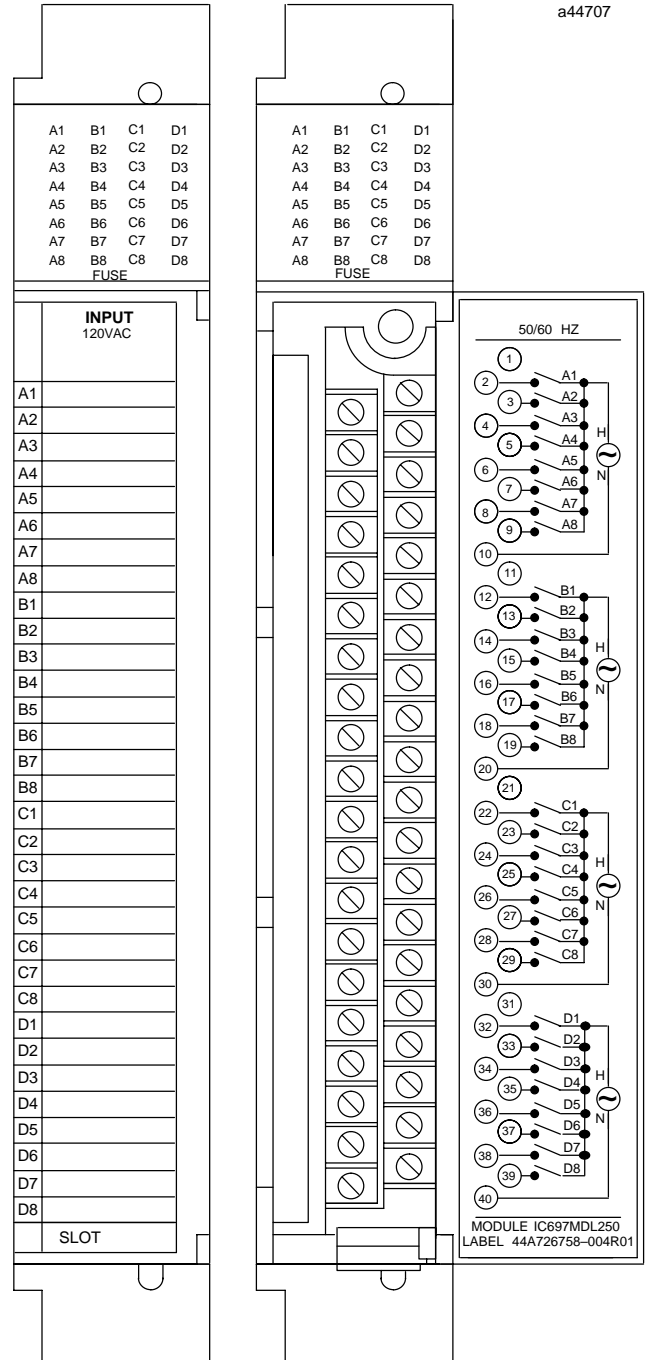

® IBM and PS/2 are registered trademarks of International Business Machines Corporation.

® MS-DOS, Windows, Windows 95, and Windows NT are registered trademarks of Microsoft Corporation.

Operation of the 120 VOLT AC Input Module

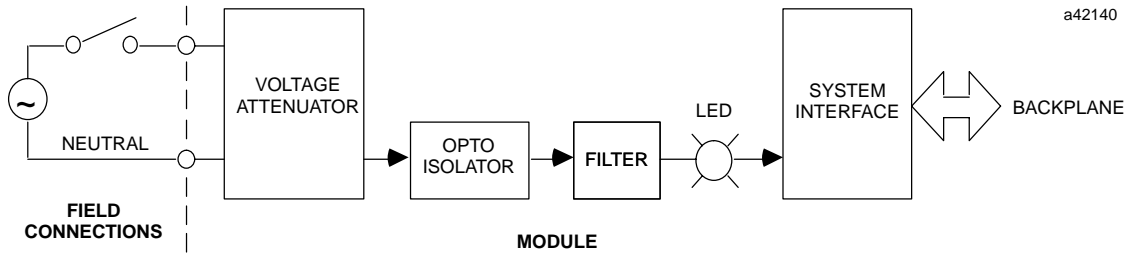

Input Characteristics

The 120 Volt AC Input Module is compatible with a wide variety of input devices, such as:

- Pushbuttons, limit switches, selector switches
- Electronic proximity switches, both 2-wire and 3-wire

The input circuitry is capacitive to give low heat dissipation and associated high reliability and long life.

Input current characteristics provide 10mA typically in the ON state, and can sink up to 2.2mA of leakage current in the OFF state to the input device.

This module is compatible with a wide range of both 2-wire and 3-wire proximity switches. To determine compatibility with a specific proximity switch, find the ON state characteristics of the switch in the illustration below.

If that point falls to the left of the input load line, the ON state characteristics are compatible. As an example, the ON state requirements of a compatible proximity switch of 5mA at 20 volts drop is shown.

In addition, the OFF-state current must be less than 2.2mA.

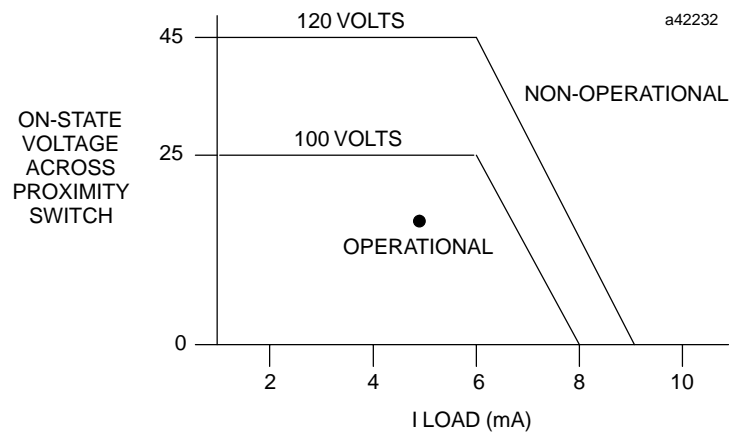

120 Volt AC, 32-Point Input Module

GFK-0084J
August 1997

Module Power

The 120 Volt AC Input Module requires 0.35 amps from the 5-volt bus on the backplane.

Module Mechanical Keying

This module includes a mechanical key that prevents inadvertent substitution of one module type for another in a given slot. The key fits a uniquely shaped area on the board below the connector. The key is included with each module.

When the module is first installed, the key latches onto the backplane center rail. When the module is extracted, the key remains in the center rail, configuring the slot to accept only identical module types.

If it is necessary to change the module location in the rack after the key has been latched onto the center rail of the rack, the key can be removed by pushing it upward to unhook the latch while pulling it off the rail. It may then be reinserted onto the module and the module inserted into the rack in the desired location. Note that only the power supply can be placed in the leftmost rack position.

Field Wiring

The module is wired as shown in the illustration on the right of this page. Since each group of eight inputs is isolated from the others, a wire from the power source to the power input terminal for each group (terminal number 10, 20, 30, or 40) is required (power input terminals for each group are not connected inside the module).

The detachable field wiring terminal board accepts wire sizes from #22 (0.36 mm²) through #14 (2.10 mm²). Two wires may be terminated on a given lug if both wires are the same size. There is room for a bundle of forty #14 wires to be routed out through the terminal board cavity.

The wire bundle can be secured to the terminal board by passing a cable tie through a cleat located at the lower corner of the terminal board.

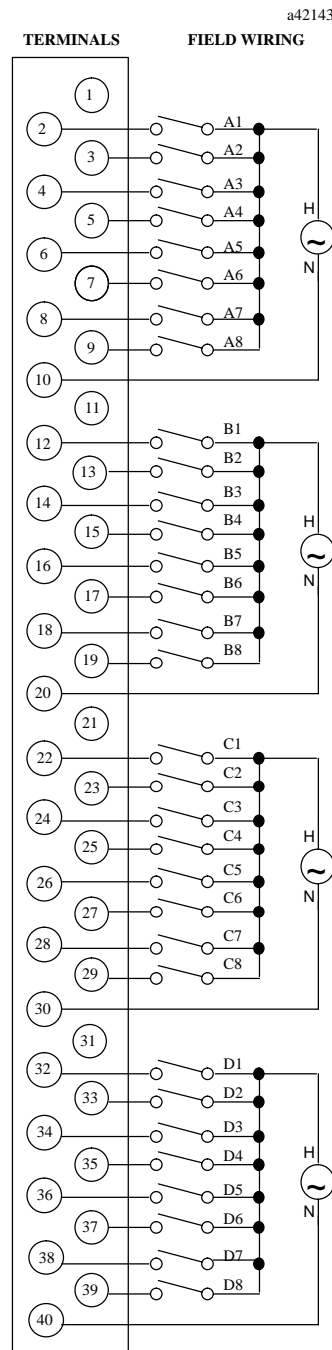

GFK-0084J
August 1997

120 Volt AC, 32-Point Input Module

Recommended Field Wiring Procedures

The following procedures are recommended when connecting field wiring to the detachable terminal board on this input

module. Module features referenced in the following procedures which are common to all IC697 I/O modules are illustrated in the following figure.

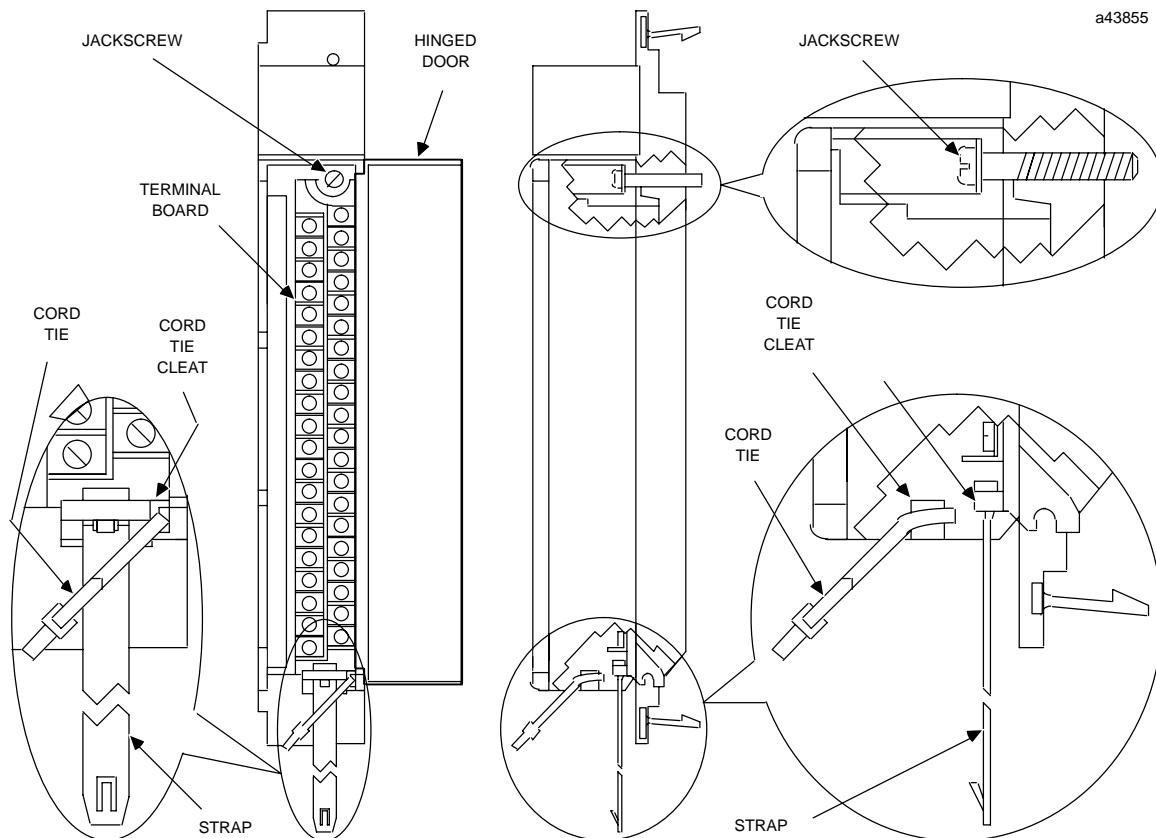

Figure 1. I/O Module Features

1. Turn off power before removing or installing terminal boards. Open the hinged door on the module to access a jackscrew which holds the terminal board securely in place. The detachable field wiring terminal board can now be removed from the module by turning the jackscrew counter-clockwise until it is fully disengaged.
2. To remove the terminal board, grasp the top of the terminal board and swing it outward as shown in Figure 2.
3. The terminal board is designed to accept wire sizes from AWG #22 (0.36 mm) through AWG #14 (2.10 mm). It is important that when using AWG #14 (2.10 mm²) wire for wiring all points, that a maximum insulation diameter of .135 inch (3.43mm) not be exceeded. To ensure proper connection, two wires may be terminated on any one terminal only if both wires are the same size.
4. The terminal board is designed to accept a maximum of (40) AWG #14 (2.10 mm²) wires. If AWG #14 (2.10 mm²) wires are to be used, then wire markers should be placed at least 8 inches (203 mm) from termination end to provide sufficient space for the hinged door to close.

Caution

Do not use the hinged door to remove the terminal board. The hinged door could be damaged if this is done.

120 Volt AC, 32-Point Input Module

GFK-0084J
August 1997

Figure 2. Removal of I/O Terminal Board

5. After completing connections to all modules in a rack, the wire bundle must be secured. To ensure that the wire bundle is secured properly, it is recommended that a cable tie be wrapped around the wire bundle and tightly secured through the cable tie cleat located at the lower right corner of the terminal board. For extremely large wire bundles, additional cable ties should be used.
6. A door label insert is included with each module to indicate circuit wiring information and provide space to record user circuit wiring identification. A slot is provided on the hinged door to allow for insertion of this label. If the label is difficult to insert, crease the scored edge before insertion. The outside label has a color coded stripe to allow quick identification of the module voltage type (blue: low voltage; red: high voltage).
7. After field wiring is completed, the terminal board should be securely fastened to the rack by inserting the terminal board strap (attached to each module) into the small rectangular slots in the bottom card guide grill on the rack. This strap not

only secures the terminal board to the rack, it also provides a way of identifying the wired terminal board with its correct mating rack slot location.

8. For adequate module ventilation, it is recommended that at least a 6 inch (152mm) clearance be allowed above and below the rack grill. Wire bundles should not obstruct the rack grill work.

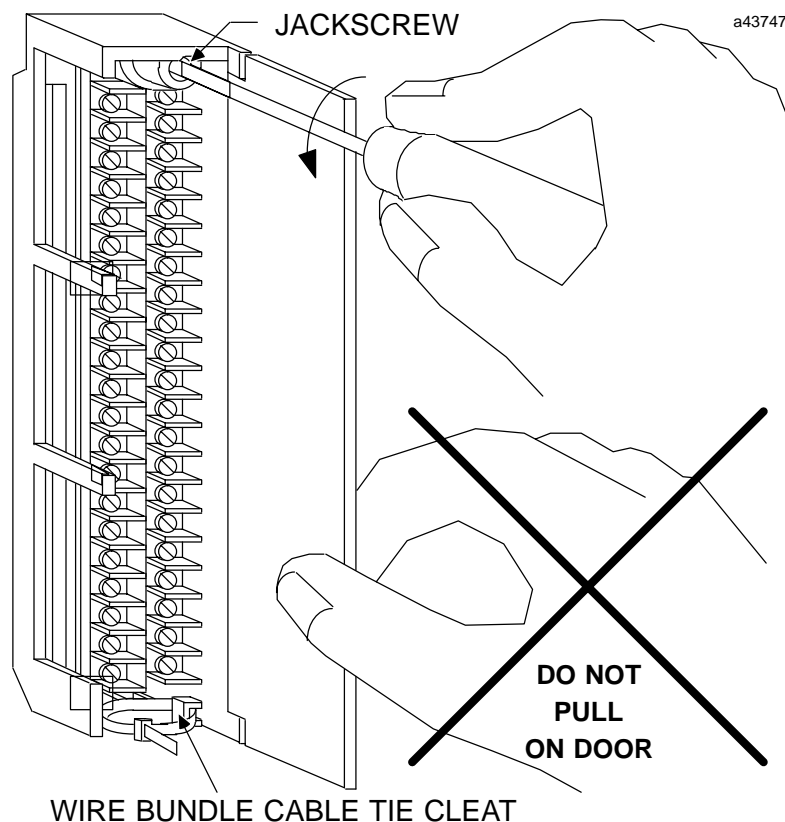
Removing an I/O Module

The instructions below should be followed when removing an I/O module from its slot in a rack.

- Grasp the board firmly at the top and bottom of the board cover with your thumbs on the front of the cover and your fingers on the plastic clips on the back of the cover.
- Squeeze the rack clips on the back of the cover with your fingers to disengage the clip from the rack rail and pull the board firmly to remove it from the backplane connector.
- Slide the board along the card guide and remove it from the rack.

GFK-0084J
August 1997

120 Volt AC, 32-Point Input Module

Table 1. Specifications for IC697MDL250 †

Rated Voltage:	120 VAC, 47 to 63 Hz Sinusoidal
Inputs per Module:	32 (four groups of eight inputs each)
Isolation:	1500 volts RMS - any input to backplane 500 volts RMS between input groups
Input Current:	10mA (typical) at rated voltage (reactive)
Input Characteristics -	
On-state Voltage:	75 to 132 volts AC, 47 to 63 Hz Sinusoidal
Off-state Voltage:	0 to 25 volts AC, 47 to 63 Hz Sinusoidal
On-state Current:	6mA to 15mA
Off-state Current:	0 to 3mA (2.2 minimum at 25V input)
Filter Delay Time:	20mstypical
Current Required from 5VDC backplane bus:	0.35 amps
VME	System designed to support the VME standard C.1

† Refer to GFK-0867B, or later for product standards and general specifications. For installations requiring compliance to more stringent requirements (for example, FCC or European Union Directives), refer to *Installation Requirements for Conformance to Standards*.

Table 2. Ordering Information

Description	Catalog Number
Input Module - 120 Volt AC, 32 Points	IC697MDL250

Note: For Conformal Coat option, or Low Temperature Testing option please consult the factory for price and availability.

Discrete Input Modules

IC697MDL240

GFK-0375E
August 1997

120 Volt AC, Isolated, 16-Point Input Module

Features

- 16 Isolated Points
- 20 ms input filter
- Proximity switch compatible

Functions

The **120 Volt AC Isolated Input Module** provides 16 input points which are isolated. This allows each point to be used on a different phase of the AC supply.

The input is reactive (resistor/capacitor input) with current-voltage characteristics which meet IEC standard (type 2). The input characteristics are compatible with a large range of available proximity switches.

LED indicators which give the ON-OFF status of each point on the logic (PLC) side of the circuit are included at the top of the module.

The module is mechanically keyed to allow correct replacement with a similar type in the field. I/O references are user configurable without the use of jumpers or DIP switches on the module.

Configuration is done using the configuration function of the MS-DOS® or Windows® programming software running on Windows® 95 or Windows NT® over Ethernet TCP/IP or through the SNP port. The Programming Software configuration function is installed on the programming device. The programming device can be an IBM® XT, AT/PS/2® or compatible Personal Computer.

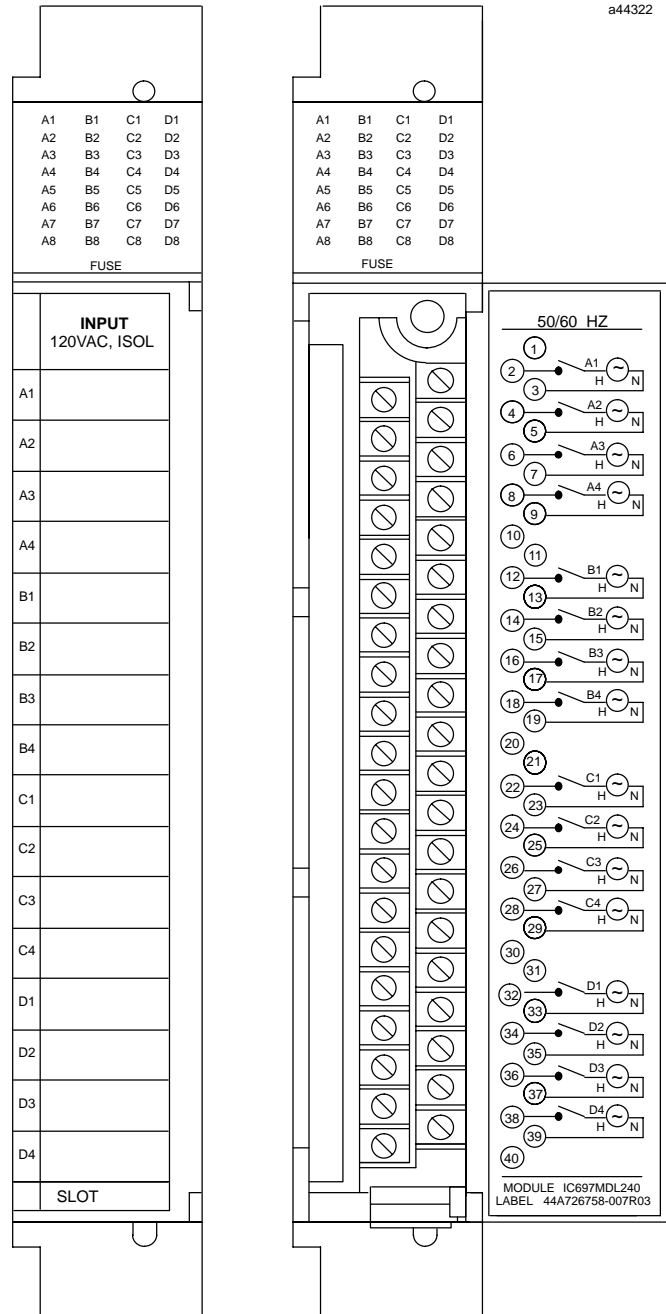

© IBM and PS/2 are registered trademarks of International Business Machines Corporation.

© MS-DOS, Windows, Windows 95, and Windows NT are registered trademarks of Microsoft Corporation.

Operation of the 120 Volt AC Isolated Input Module

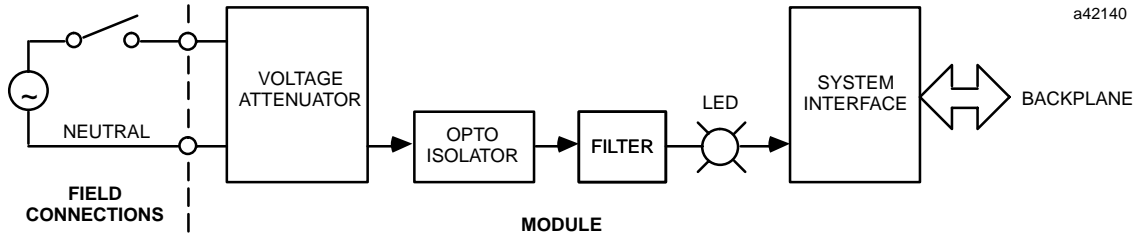

Figure 1. Block Diagram for IC697MDL240

Input Characteristics

The 120 Volt AC Isolated Input Module is compatible with a wide variety of input devices, such as:

- Pushbuttons, limit switches, selector switches
- Electronic proximity switches, both 2-wire and 3-wire

The input circuitry is capacitive to give low heat dissipation and associated high reliability and long life.

Input current characteristics provide 10mA typically in the ON state, and can sink up to 4mA of leakage current in the OFF state to the input device.

This module is compatible with a wide range of both 2-wire and 3-wire proximity switches. To determine compatibility with a specific proximity switch, find the ON state characteristics of the switch in the illustration below. If that point falls to the left of the input load line, the ON state characteristics are compatible. As an example, the ON state requirements of a compatible proximity switch of 5mA at 20 volts drop is shown.

In addition, the OFF-state current must be less than 4mA.

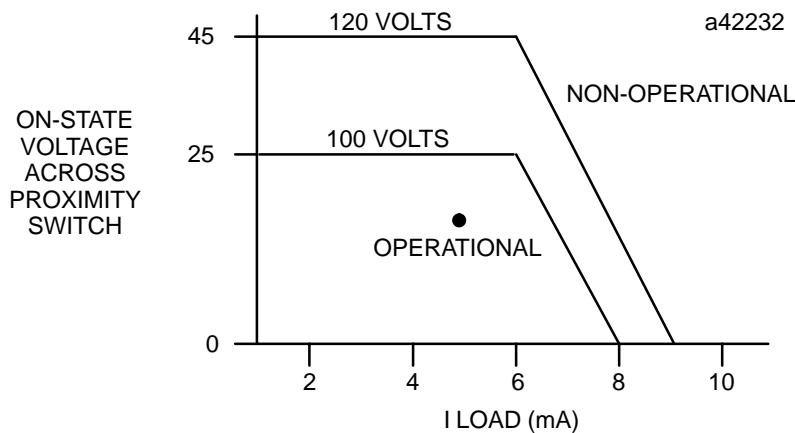

Figure 2. On-State Characteristics Compatibility

120 Volt AC, Isolated, 16-Point Input Module

GFK-0375E
August 1997

Module Power

The 120 Volt AC Isolated Input Module requires .25 amp from the 5-volt bus on the backplane.

Module Mechanical Keying

This module includes a mechanical key that prevents inadvertent substitution of one module type for another in a given slot. The key fits a uniquely shaped area on the board below the connector. The key is included with each module.

When the module is first installed, the key latches onto the backplane center rail. When the module is extracted, the key remains in the center rail, configuring the slot to accept only identical module types.

If it is necessary to change the module location in the rack after the key has been latched onto the center rail of the rack, the key can be removed by pushing it upward to unhook the latch while pulling it off the rail. It may then be reinserted onto the module and the module inserted into the rack in the desired location. Note: Only the power supply can be placed in the leftmost rack position.

Field Wiring

The module is wired as shown in Figure 3. Since each input is isolated (separate) from each of the other inputs, each input can be powered by a separate power source.

The detachable field wiring terminal board will accept wire sizes from AWG #22 (0.36 mm²) through AWG #14 (2.10 mm²). Two wires may be terminated on a given lug if both wires are the same size. There is room for a bundle of forty AWG #14 (2.10 mm²) wires to be routed out through the terminal board cavity.

The wire bundle can be secured to the terminal board by passing a cable tie through a cleat located at the lower corner of the terminal board.

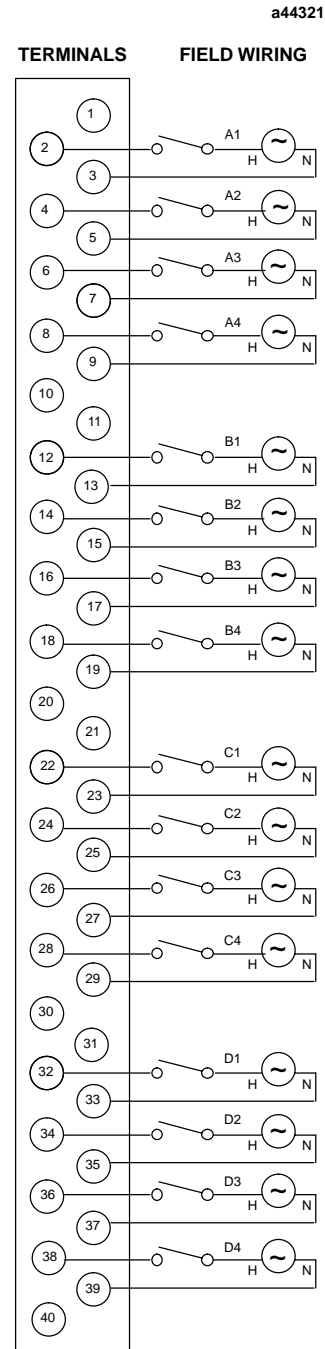

Figure 3. Field Wiring Connections

GFK-0375E
August 1997

120 Volt AC, Isolated, 16-Point Input Module

Recommended Field Wiring Procedures

The following procedures are recommended when connecting field wiring to the detachable terminal board on this input

module. Module features referenced in the following procedures which are common to all IC697 I/O modules are illustrated in the following figure.

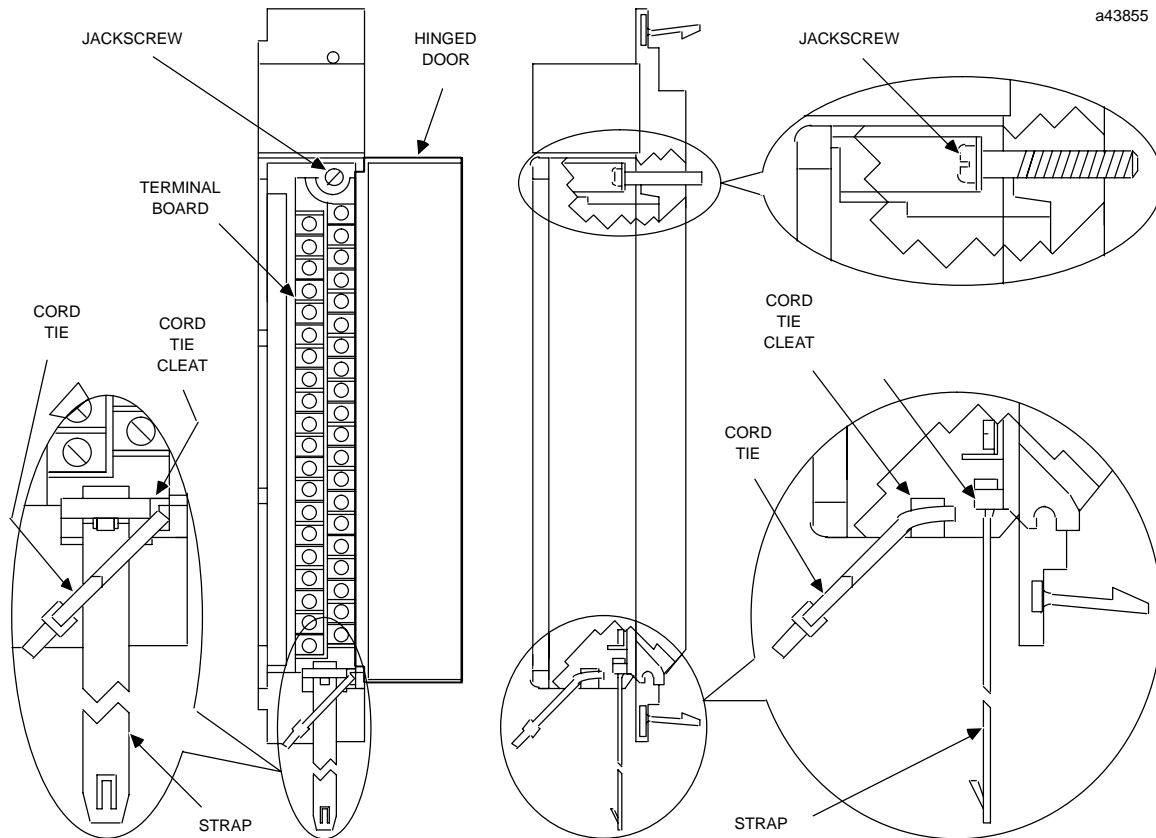

Figure 4. I/O Module Features

1. Turn off power before removing or installing terminal boards. Open the hinged door on the module to access a jackscrew which holds the terminal board securely in place. The detachable field wiring terminal board can now be removed from the module by turning the jackscrew counter-clockwise until it is fully disengaged.
2. To remove the terminal board, grasp the top of the terminal board and swing it outward as shown in Figure 5.
3. The terminal board is designed to accept wire sizes from AWG #22 (0.36 mm²) through AWG #14 (2.10 mm²). It is important that when using AWG #14 (2.10 mm²) wire for wiring all points, that a maximum insulation diameter of .135 inch (3.43mm) not be exceeded. To ensure proper connection, two wires may be terminated on any one terminal only if both wires are the same size.
4. The terminal board is designed to accept a maximum of (40) AWG #14 (2.10 mm²) wires. If AWG #14 (2.10 mm²) wires are to be used, then wire markers should be placed at least 8 inches (203 mm) from termination end to provide sufficient space for the hinged door to close.

Caution

Do not use the hinged door to remove the terminal board. The hinged door could be damaged if this is done.

120 Volt AC, Isolated, 16-Point Input Module

GFK-0375E
August 1997

Figure 5. Removal of I/O Terminal Board

5. After completing connections to all modules in a rack, the wire bundle must be secured. To ensure that the wire bundle is secured properly, it is recommended that a cable tie be wrapped around the wire bundle and tightly secured through the cable tie cleat located at the lower right corner of the terminal board. For extremely large wire bundles, additional cable ties should be used.
6. A door label insert is included with each module to indicate circuit wiring information and provide space to record user circuit wiring identification. A slot is provided on the hinged door to allow for insertion of this label. If the label is difficult to insert, crease the scored edge before insertion. The outside label has a color coded stripe to allow quick identification of the module voltage type (blue: low voltage; red: high voltage).
7. After field wiring is completed, the terminal board should be securely fastened to the rack by inserting the terminal board strap (attached to each module) into the small rectangular slots in the bottom card guide grill on the rack. This strap not

only secures the terminal board to the rack, it also provides a way of identifying the wired terminal board with its correct mating rack slot location.

8. For adequate module ventilation, it is recommended that at least a 6 inch (152mm) clearance be allowed above and below the rack grill. Wire bundles should not obstruct the rack grill work.

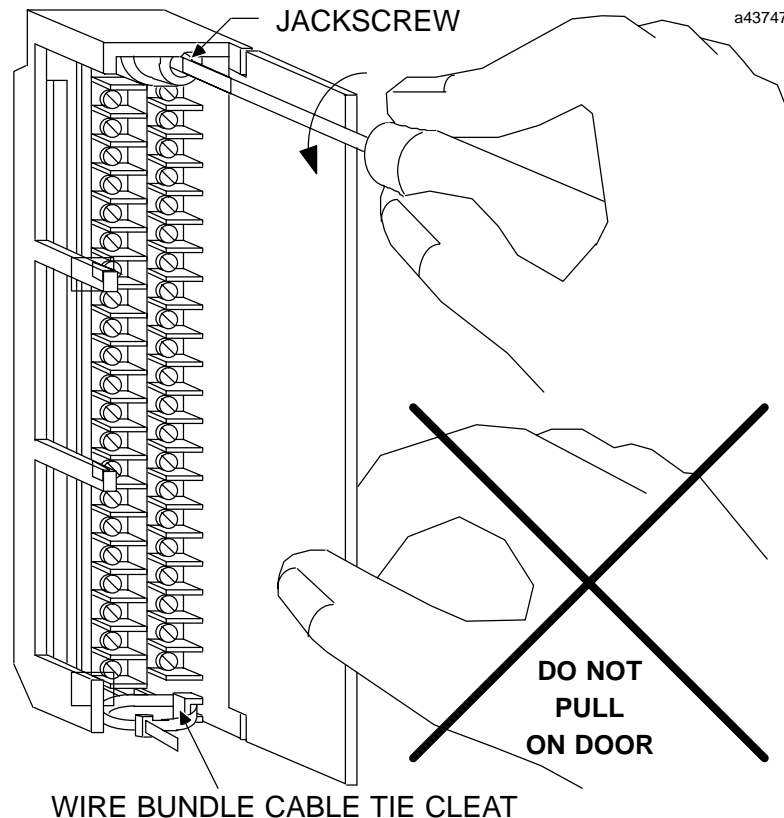
Removing an I/O Module

The instructions below should be followed when removing an I/O module from its slot in a rack.

- Grasp the board firmly at the top and bottom of the board cover with your thumbs on the front of the cover and your fingers on the plastic clips on the back of the cover.
- Squeeze the rack clips on the back of the cover with your fingers to disengage the clip from the rack rail and pull the board firmly to remove it from the backplane connector.
- Slide the board along the card guide and remove it from the rack.

GFK-0375E
August 1997

120 Volt AC, Isolated, 16-Point Input Module

Table 1. Specifications for IC697MDL240 †

Rated Voltage Inputs per Module	120 volts AC, 60 Hz sinusoidal 16 individually isolated
Isolation	1500 volts RMS - any input to backplane 500 volts RMS between inputs
Input Current Input Characteristics	10mA (typical) at rated voltage (reactive)
On-state Voltage	75 volts to 132 volts, 60 Hz sinusoidal
Off-state Voltage	0 to 20 volts, 60 Hz sinusoidal
On-state Current	8mA to 15 mA
Off-state Current	0 to 4mA (2.2mA minimum at 25V input)
Filter Delay Time	20mstypical
Current Req. from 5V Bus	0.25 amps
VME	System designed to support the VME standard C.1

† Refer to GFK-0867B, or later for product standards and general specifications. For installations requiring compliance to more stringent requirements (for example, FCC or European Union Directives), refer to *Installation Requirements for Conformance to Standards*.

Table 2. Ordering Information

Description	Catalog Number
Input Module - 120 Volt AC, 16 Points, Isolated	IC697MDL240

Note: For Conformal Coat option, or Low Temperature Testing option please consult the factory for price and availability.

Discrete Input Modules

IC697MDL251

GFK-0718C
August 1997

120 Volt AC, 16-Point Input Module

Features

- 16 Points - Four isolated groups of 4 points each
- 20 ms input filter
- Proximity switch compatible

Functions

This **120 volt AC Input** module provides 16 input points in four isolated groups of four points each. This allows each group of four points to be used on a different phase of the AC supply.

The input is reactive (resistor/capacitor input) with current-voltage characteristics which meet IEC standard (type 2). The input characteristics are compatible with a large range of available proximity switches.

LED indicators which give the ON-OFF status of each point on the logic (PLC) side of the circuit are included at the top of the module.

The module is mechanically keyed to ensure correct replacement with a similar type in the field. I/O references are user configurable without the use of jumpers or DIP switches on the module.

Configuration is done using the configuration function of the MS-DOS® or Windows® programming software running on Windows® 95 or Windows NT® over Ethernet TCP/IP or through the SNP port. The Programming Software configuration function is installed on the programming device. The programming device can be an IBM® XT, AT, PS/2® or compatible Personal Computer.

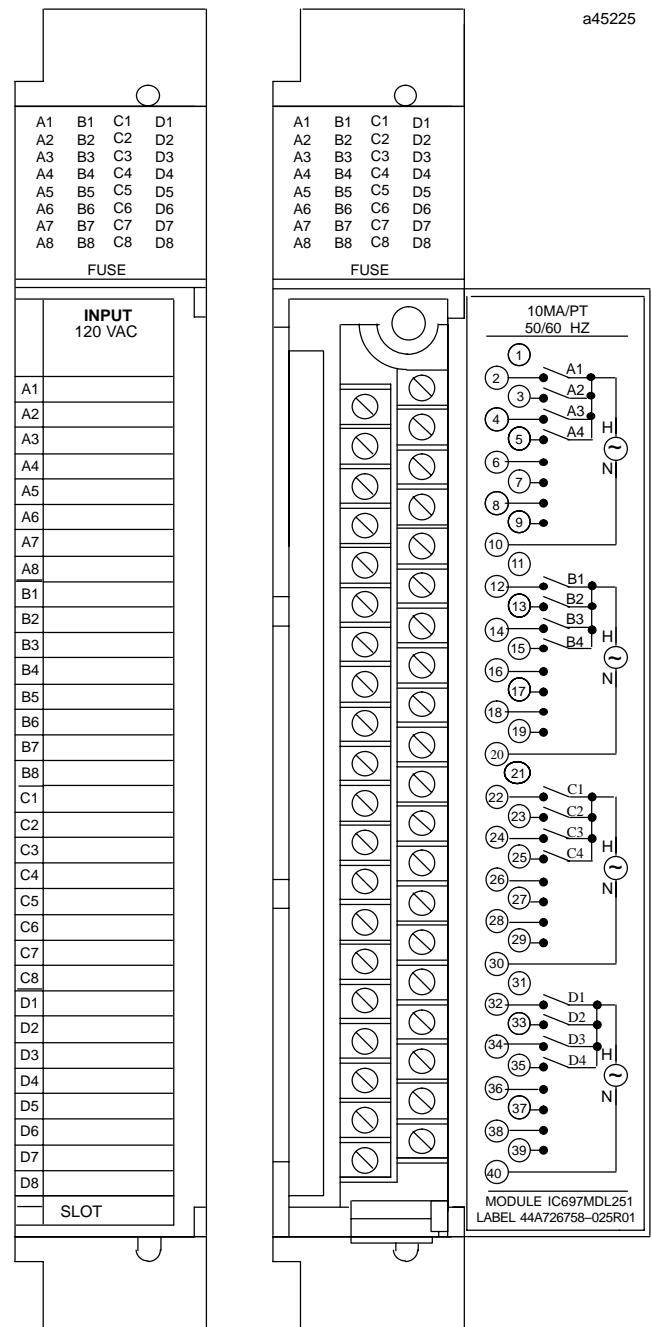

® IBM and PS/2 are registered trademarks of International Business Machines Corporation.

® MS-DOS, Windows, Windows 95, and Windows NT are registered trademarks of Microsoft Corporation.

Operation of the 120 VOLT AC16 Point Input Module

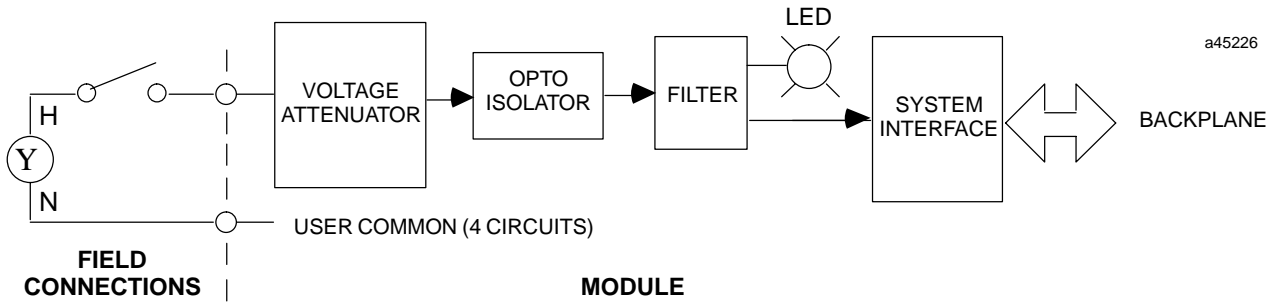

Figure 1. Block Diagram for IC697MDL251

Input Characteristics

The 120 Volt AC 16 Point Input Module is compatible with a wide variety of input devices, such as:

- Pushbuttons, limit switches, selector switches
- Electronic proximity switches, both 2-wire and 3-wire

The input circuitry is capacitive to give low heat dissipation and associated high reliability and long life.

Input current characteristics provide 10mA typically in the ON state, and can sink up to 2.2mA of leakage current in the OFF state to the input device.

This module is compatible with a wide range of both 2-wire and 3-wire proximity switches. To determine compatibility with a specific proximity switch, find the ON state characteristics of the switch in the illustration below.

If that point falls to the left of the input load line, the ON state characteristics are compatible. As an example, the ON state requirements of a compatible proximity switch of 5mA at 20 volts drop is shown.

In addition, the OFF-state current must be less than 2.2mA.

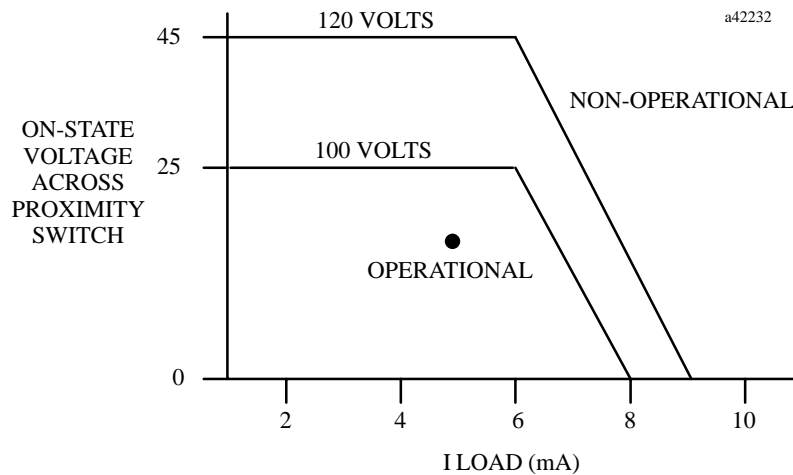

Figure 2. Proximity Switch Compatibility

120 Volt AC, 16-Point Input Module

GFK-0718C
August 1997

Module Power

The 120 Volt AC 16 Point Input Module requires 0.35 amps from the 5 volt bus on the backplane.

Module Mechanical Keying

This module includes a mechanical key that prevents inadvertent substitution of one module type for another in a given slot. The key fits a uniquely shaped area on the board below the connector. The key is included with each module.

When the module is first installed, the key latches onto the backplane center rail. When the module is extracted, the key remains in the center rail, configuring the slot to accept only identical module types.

If it is necessary to change the module location in the rack after the key has been latched onto the center rail of the rack, the key can be removed by pushing it upward to unhook the latch while pulling it off the rail. It may then be reinserted onto the module and the module inserted into the rack in the desired location. Note that only the power supply can be placed in the leftmost rack position.

Field Wiring

The module is wired as shown in the illustration on the right of this page. Since each group of four inputs is isolated from the others, a wire from the power source to the power input terminal for each group (terminal number 10, 20, 30, or 40) is required (power input terminals for each group are not connected inside the module).

The detachable field wiring terminal board will accept wire sizes from #22 (0.36 mm²) through #14 (2.10 mm²). Two wires may be terminated on a given lug if both wires are the same size. There is room for a bundle of forty #14 (2.10 mm²) wires to be routed out through the terminal board cavity.

The wire bundle can be secured to the terminal board by passing a cable tie through a cleat located at the lower corner of the terminal board.

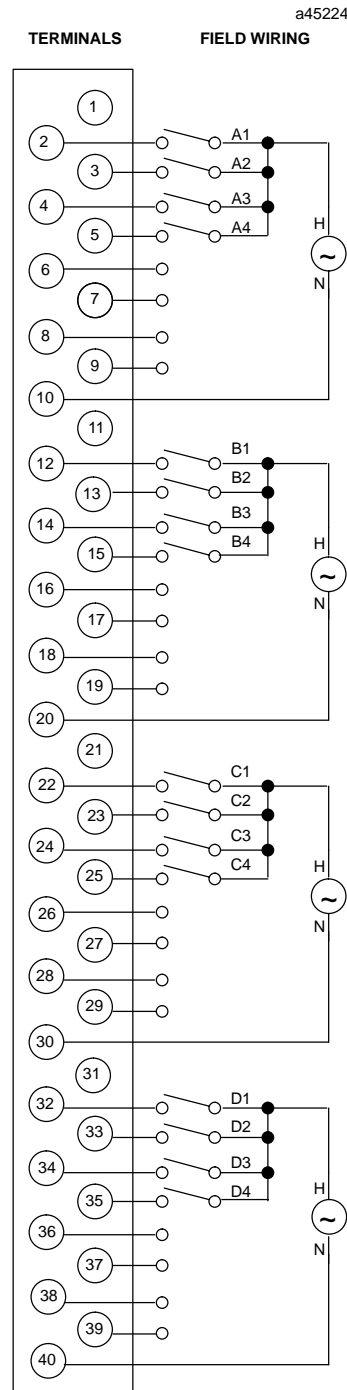

GFK-0718C
August 1997

120 Volt AC, 16-Point Input Module

Recommended Field Wiring Procedures

The following procedures are recommended when connecting field wiring to the detachable terminal board on this input

module. Module features referenced in the following procedures which are common to all I/O modules for the IC697 PLC are illustrated in the following figure.

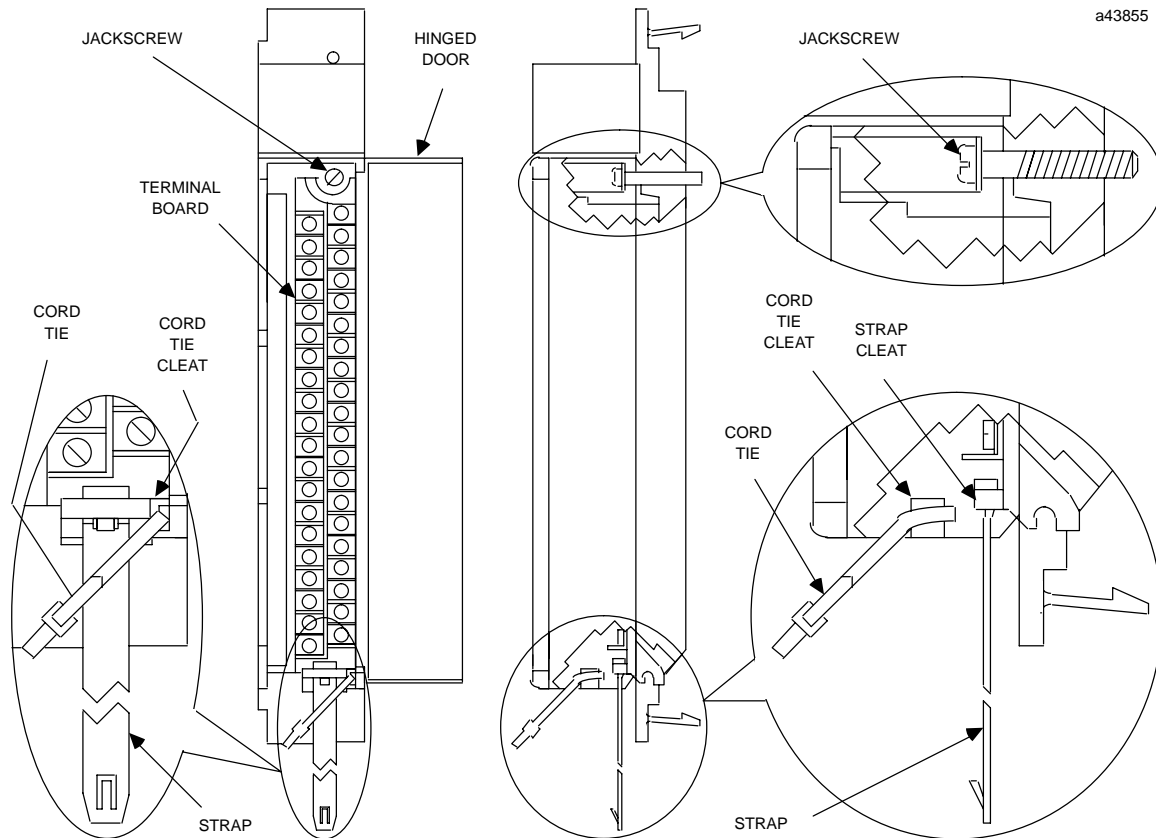

Figure 3. I/O Module Features

1. Turn off power before removing or installing terminal boards. Open the hinged door on the module to access a jackscrew which holds the terminal board securely in place. The Detachable field wiring terminal board can now be removed from the module by turning the jackscrew counter-clockwise until it is fully disengaged.
2. To remove the terminal board, grasp the top of the terminal board and swing it outward as shown in Figure 2.
3. The terminal board is designed to accept wire sizes from AWG #22 (0.36 mm²) through AWG #14 (2.10 mm²). It is important that when using AWG #14 (2.10 mm²) wire for wiring all points, that a maximum insulation diameter of .135 inch (3.43 mm) not be exceeded. To ensure proper connection, two wires may be terminated on any one terminal only if both wires are the same size.
4. The terminal board is designed to accept a maximum of (40) AWG #14 (2.10 mm²) wires. If AWG #14 (2.10 mm²) wires are to be used, then wire markers should be placed at least 8 inches (203 mm) from termination end to provide sufficient space for the hinged door to close.

Caution

Do not use the hinged door to remove the terminal board. The hinged door could be damaged if this is done.

120 Volt AC, 16-Point Input Module

GFK-0718C
August 1997

Figure 4. Removal of I/O Terminal Board

5. After completing connections to all modules in a rack, the wire bundle must be secured. To ensure that the wire bundle is secured properly, it is recommended that a cable tie be wrapped around the wire bundle and tightly secured through the cable tie cleat located at the lower right corner of the terminal board. For extremely large wire bundles, additional cable ties should be used.
6. A door label insert is included with each module to indicate circuit wiring information and provide space to record user circuit wiring identification. A slot is provided on the hinged door to allow for insertion of this label. If the label is difficult to insert, crease the scored edge before insertion. The outside label has a color coded stripe to allow quick identification of the module voltage type (blue: low voltage; red: high voltage).
7. After field wiring is completed, the terminal board should be securely fastened to the rack by inserting the terminal board strap (attached to each module) into the small rectangular slots in the bottom card guide grill on the rack. This strap not

only secures the terminal board to the rack, it also provides a way of identifying the wired terminal board with its correct mating rack slot location.

8. For adequate module ventilation, it is recommended that at least a 6 inch (152 mm) clearance be allowed above and below the rack grill. Wire bundles should not obstruct the rack grill work.

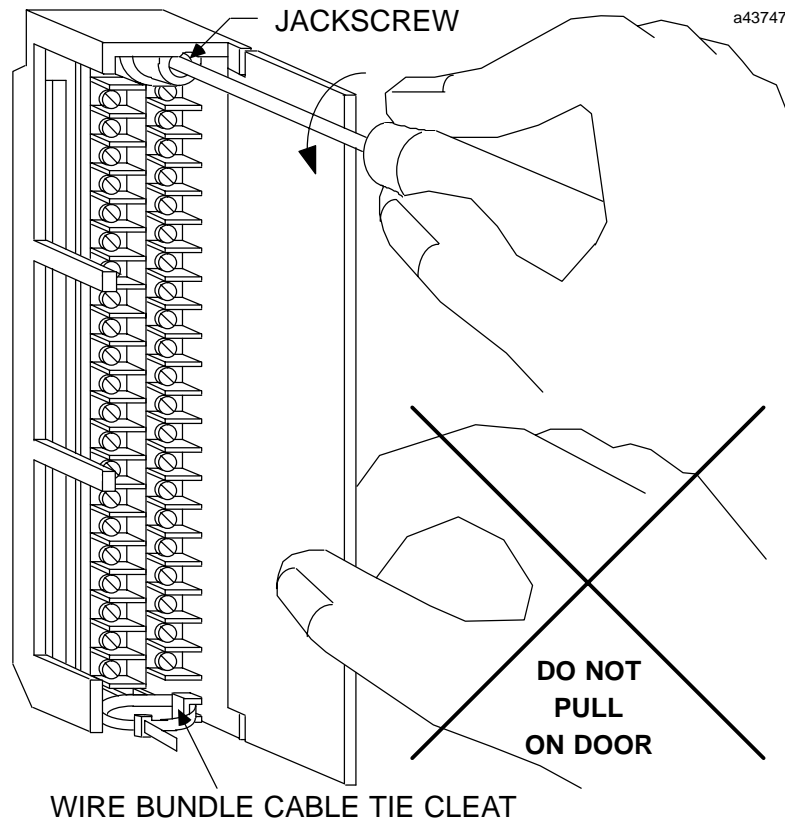
Removing an I/O Module

The instructions below should be followed when removing an I/O module from its slot in a rack.

- Grasp the board firmly at the top and bottom of the board cover with your thumbs on the front of the cover and your fingers on the plastic clips on the back of the cover.
- Squeeze the rack clips on the back of the cover with your fingers to disengage the clip from the rack rail and pull the board firmly to remove it from the backplane connector.
- Slide the board along the card guide and remove it from the rack.

GFK-0718C
August 1997

120 Volt AC, 16-Point Input Module

Table 1. Specifications for IC697MDL251 †

Rated Voltage:	120 VAC, 47 to 63 Hz Sinusoidal
Inputs per Module:	16 (four groups of four inputs each)
Isolation:	1500 volts RMS - any input to backplane 500 volts RMS between input groups
Input Current:	10mA (typical) at rated voltage (reactive)
Input Characteristics -	
On-state Voltage:	75 to 132 volts AC, 47 to 63 Hz Sinusoidal
Off-state Voltage:	0 to 25 volts AC, 47 to 63 Hz Sinusoidal
On-state Current:	6mA to 15mA
Off-state Current:	0 to 3mA (2.2 minimum at 25V input)
Filter Delay Time:	20mstypical
Current Required from 5VDC backplane bus:	0.35 amps
VME	System designed to support the VME standard C.1

† Refer to GFK-0867B, or later for product standards and general specifications. For installations requiring compliance to more stringent requirements (for example, FCC or European Union Directives), refer to *Installation Requirements for Conformance to Standards*.

Table 2. Ordering Information

Description	Catalog Number
Input Module: 120 Volt AC, 16 Points	IC697MDL251

Note: For Conformal Coat option, or Low Temperature Testing option please consult the factory for price and availability.

Discrete Input Modules

IC697MDL241

GFK-0376G
August 1997

240 Volt AC, Isolated 16-Point Input Module

Features

- 16 individually isolated points
- 20 ms input filter
- Proximity switch compatible

Functions

This **240 volt AC Isolated Input** module for use with a Programmable Logic Controller (PLC) provides 16 isolated input points. This allows each point to be used on a different phase of the AC supply.

The input is reactive (resistor/capacitor input) with current-voltage characteristics which meet IEC standard (type 2). The input characteristics are compatible with a large range of available proximity switches.

LED indicators which give the ON-OFF status of each point on the logic (PLC) side of the circuit are included at the top of the module.

The module is mechanically keyed to ensure correct replacement with a similar type in the field. I/O references are user configurable without the use of jumpers or DIP switches on the module.

Configuration is done using the configuration function of the MS-DOS® or Windows® programming software running on Windows® 95 or Windows NT® over Ethernet TCP/IP or through the SNP port. The Programming Software configuration function is installed on the programming device. The programming device can be an IBM® XT, AT/PS/2® or compatible Personal Computer.

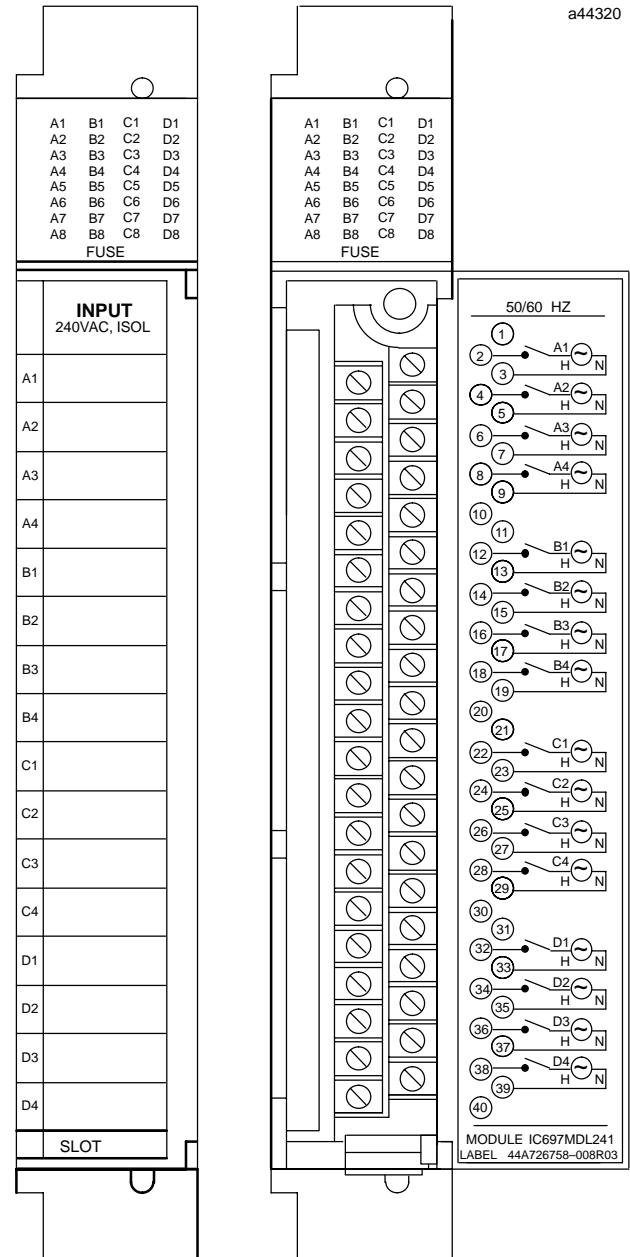

® IBM and PS/2 are registered trademarks of International Business Machines Corporation.

® MS-DOS, Windows, Windows 95, and Windows NT are registered trademarks of Microsoft Corporation.

Operation of the 240 VOLT AC 16 Point Input Module

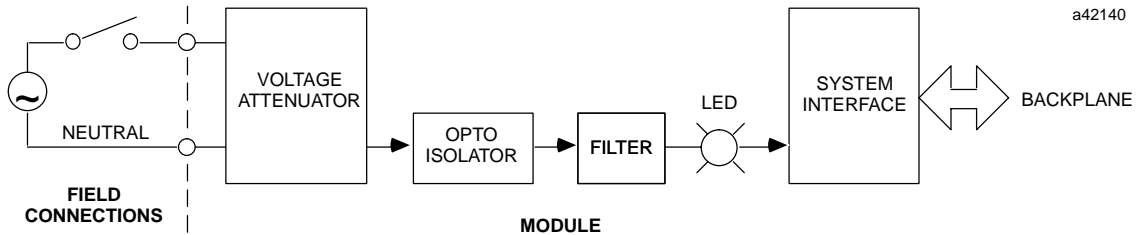

Figure 1. Block Diagram for IC697MDL241

Input Characteristics

The 240 Volt AC Isolated Input Module is compatible with a wide variety of input devices, such as:

- Pushbuttons, limit switches, selector switches
- Electronic proximity switches, both 2-wire and 3-wire

The input circuitry is capacitive to give low heat dissipation and associated high reliability and long life.

Input current characteristics provide 10mA typically in the ON state, and can sink up to 5mA of leakage current in the OFF state to the input device.

This module is compatible with a wide range of both 2-wire and 3-wire proximity switches. To determine compatibility with a specific proximity switch, find the ON state characteristics of the switch in the illustration below.

If that point falls to the left of the input load line, the ON state characteristics are compatible. As an example, the ON state requirements of a compatible proximity switch of 5mA at 20 volts drop is shown.

In addition, the OFF-state current must be less than 5mA.

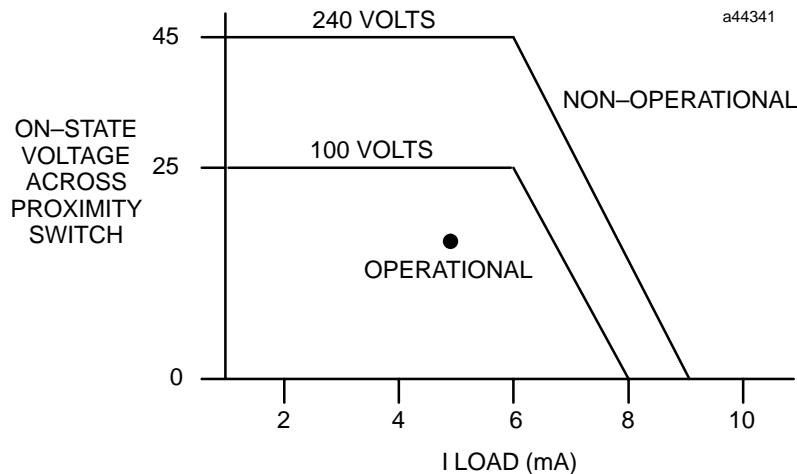

Figure 2. On-State Characteristics Compatibility

240 Volt AC, Isolated 16-Point Input Module

GFK-0376G
August 1997

Module Power

The 240 Volt AC 16 Isolated Input Module requires 0.25 amps from the 5 volt bus on the backplane.

Module Mechanical Keying

This module includes a mechanical key that prevents inadvertent substitution of one module type for another in a given slot. The key fits a uniquely shaped area on the board below the connector. This key is included with each module.

When the module is first installed, the key latches onto the backplane center rail. When the module is extracted, the key remains in the center rail, configuring the slot to accept only identical module types.

If it is necessary to change the module location in the rack after the key has been latched onto the center rail of the rack, the key can be removed by pushing it upward to unhook the latch while pulling it off the rail. It may then be reinserted onto the module and the module inserted into the rack in the desired location. Note that only the power supply can be placed in the leftmost rack position.

Field Wiring

The module is wired as shown in the illustration on the right of this page. Since each input is isolated from the other inputs, a wire from the power source to the power input terminal for each input is required (power input terminals for each input are not connected inside the module).

The detachable field wiring terminal board will accept wire sizes from #22 (0.36 mm²) through #14 (2.10 mm²). Two wires may be terminated on a given lug if both wires are the same size. There is room for a bundle of forty #14 (2.10 mm²) wires to be routed out through the terminal board cavity.

The wire bundle can be secured to the terminal board by passing a cable tie through a cleat located at the lower corner of the terminal board.

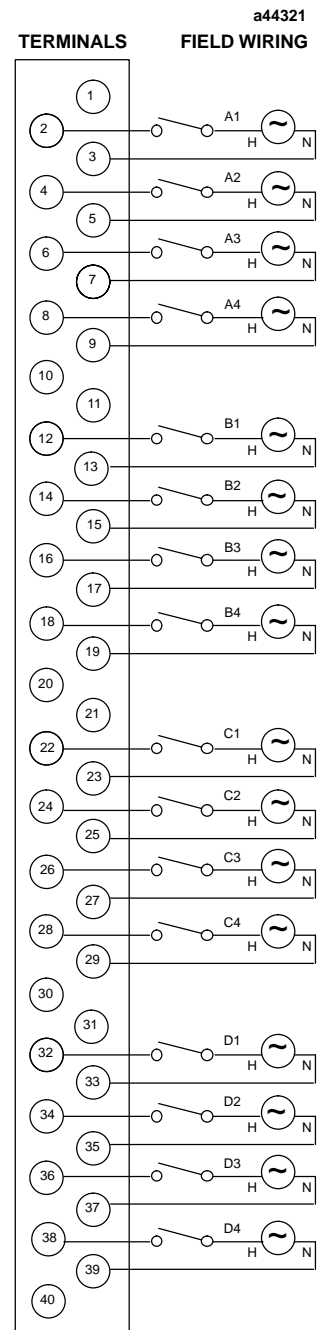

Figure 3. Field Wiring Connections for IC697MDL241

GFK-0376G
August 1997

240 Volt AC, Isolated 16-Point Input Module

Recommended Field Wiring Procedures

The following procedures are recommended when connecting field wiring to the detachable terminal board on this input

module. Module features referenced in the following procedures which are common to all IC697 I/O modules are illustrated in the following figure.

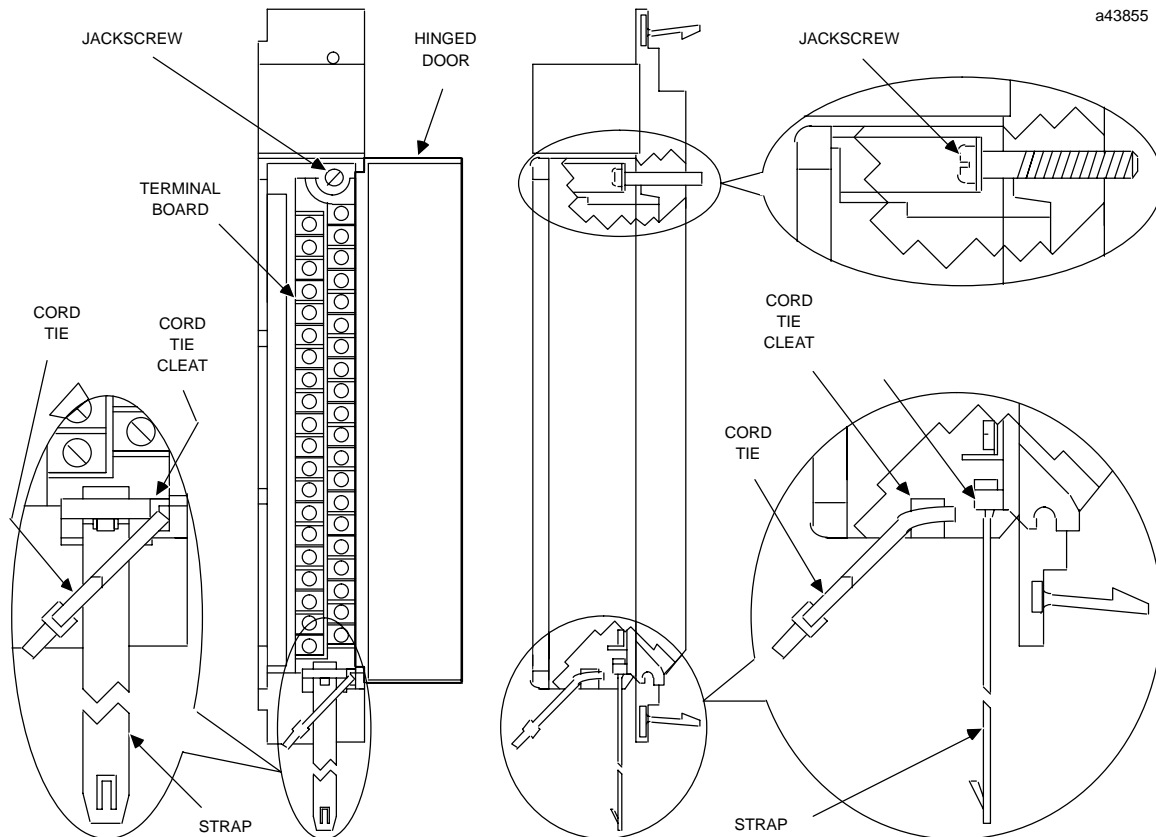

Figure 4. I/O Module Features

1. Turn off power before removing or installing terminal boards. Open the hinged door on the module to access a jackscrew which holds the terminal board securely in place. The detachable field wiring terminal board can now be removed from the module by turning the jackscrew counter-clockwise until it is fully disengaged.
2. To remove the terminal board, grasp the top of the terminal board and swing it outward as shown in Figure 2.
3. The terminal board is designed to accept wire sizes from AWG #22 (0.36 mm) through AWG #14 (2.10 mm). It is important that when using AWG #14 (2.10 mm²) wire for wiring all points, that a maximum insulation diameter of .135 inch (3.43mm) not be exceeded. To ensure proper connection, two wires may be terminated on any one terminal only if both wires are the same size.
4. The terminal board is designed to accept a maximum of (40) AWG #14 (2.10 mm²) wires. If AWG #14 (2.10 mm²) wires are to be used, then wire markers should be placed at least 8 inches (203 mm) from termination end to provide sufficient space for the hinged door to close.

Caution

Do not use the hinged door to remove the terminal board. The hinged door could be damaged if this is done.

240 Volt AC, Isolated 16-Point Input Module

GFK-0376G
August 1997

Figure 5. Removal of I/O Terminal Board

5. After completing connections to all modules in a rack, the wire bundle must be secured. To ensure that the wire bundle is secured properly, it is recommended that a cable tie be wrapped around the wire bundle and tightly secured through the cable tie cleat located at the lower right corner of the terminal board. For extremely large wire bundles, additional cable ties should be used.
6. A door label insert is included with each module to indicate circuit wiring information and provide space to record user circuit wiring identification. A slot is provided on the hinged door to allow for insertion of this label. If the label is difficult to insert, crease the scored edge before insertion. The outside label has a color coded stripe to allow quick identification of the module voltage type (blue: low voltage; red: high voltage).
7. After field wiring is completed, the terminal board should be securely fastened to the rack by inserting the terminal board strap (attached to each module) into the small rectangular slots in the bottom card guide grill on the rack. This strap not

only secures the terminal board to the rack, it also provides a way of identifying the wired terminal board with its correct mating rack slot location.

8. For adequate module ventilation, it is recommended that at least a 6 inch (152mm) clearance be allowed above and below the rack grill. Wire bundles should not obstruct the rack grill work.

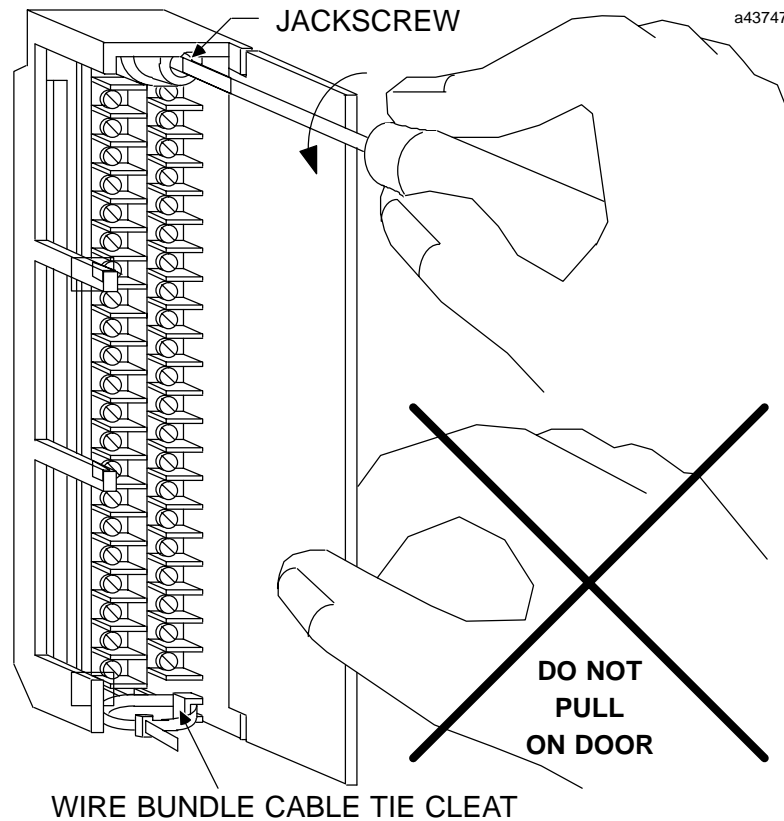
Removing an I/O Module

The instructions below should be followed when removing an I/O module from its slot in a rack.

- Grasp the board firmly at the top and bottom of the board cover with your thumbs on the front of the cover and your fingers on the plastic clips on the back of the cover.
- Squeeze the rack clips on the back of the cover with your fingers to disengage the clip from the rack rail and pull the board firmly to remove it from the backplane connector.
- Slide the board along the card guide and remove it from the rack.

GFK-0376G
August 1997

240 Volt AC, Isolated 16-Point Input Module

Table 1. Specifications for IC697MDL241 †

Rated Voltage:	240 VAC, 60 Hz Sinusoidal
Inputs per Module:	16 individually isolated
Isolation:	1500 volts RMS - any input to backplane 500 volts RMS between input groups
Input Current:	20mA (typical) at rated voltage (reactive)
Input Characteristics -	
On-state Voltage:	160 to 264 volts AC, 60 Hz Sinusoidal
Off-state Voltage:	0 to 40 volts AC, 60 Hz Sinusoidal
On-state Current:	10mA to 15mA
Off-state Current:	0 to 5mA (2.2 minimum at 40V input)
Filter Delay Time:	20mstypical
Current Required from 5VDC backplane bus:	0.25 amps
VME	System designed to support the VME standard C.1

† Refer to GFK-0867B, or later for product standards and general specifications. For installations requiring compliance to more stringent requirements (for example, FCC or European Union Directives), refer to *Installation Requirements for Conformance to Standards*.

Table 2. Ordering Information

Description	Catalog Number
Input Module: 240 Volt AC, Isolated, 16 Points	IC697MDL241

Note: For Conformal Coat option, or Low Temperature Testing option please consult the factory for price and availability.

Discrete Input Modules

IC697MDL653

GFK-0379F
August 1997

24 Volt DC Positive/Negative Logic, 32-Point Input Module

Features

- 32 Points - Four isolated groups of 8 points each
- Positive/Negative Logic Compatibility
- Proximity switch compatible
- Input filter selectable* - 1mS or 10mS
- One input configurable as interrupt*

* These features are available for all IC697 Programmable Logic Controllers (PLC). They may not be available when this module is used with other types of PLCs. See the applicable *Programmable Controllers Reference Manual* for details.

Functions

The 24 Volt DC Positive/Negative Logic Input Module provides 32 input points in four isolated groups of eight points each. The input current-voltage characteristics meet IEC standard (type 1) specifications.

LED indicators which give the ON-OFF status of each point on the logic (PLC) side of the circuit are included at the top of the module.

The module is mechanically keyed to ensure correct replacement with a similar type in the field. I/O references are user configurable without the use of jumpers or DIP switches on the module.

Configuration is done using the configuration function of the MS-DOS® or Windows® programming software running on Windows® 95 or Windows NT® over Ethernet TCP/IP or through the SNP port. The Programming Software configuration function is installed on the programming device. The programming device can be an IBM® XT, AT, PS/2® or compatible Personal Computer.

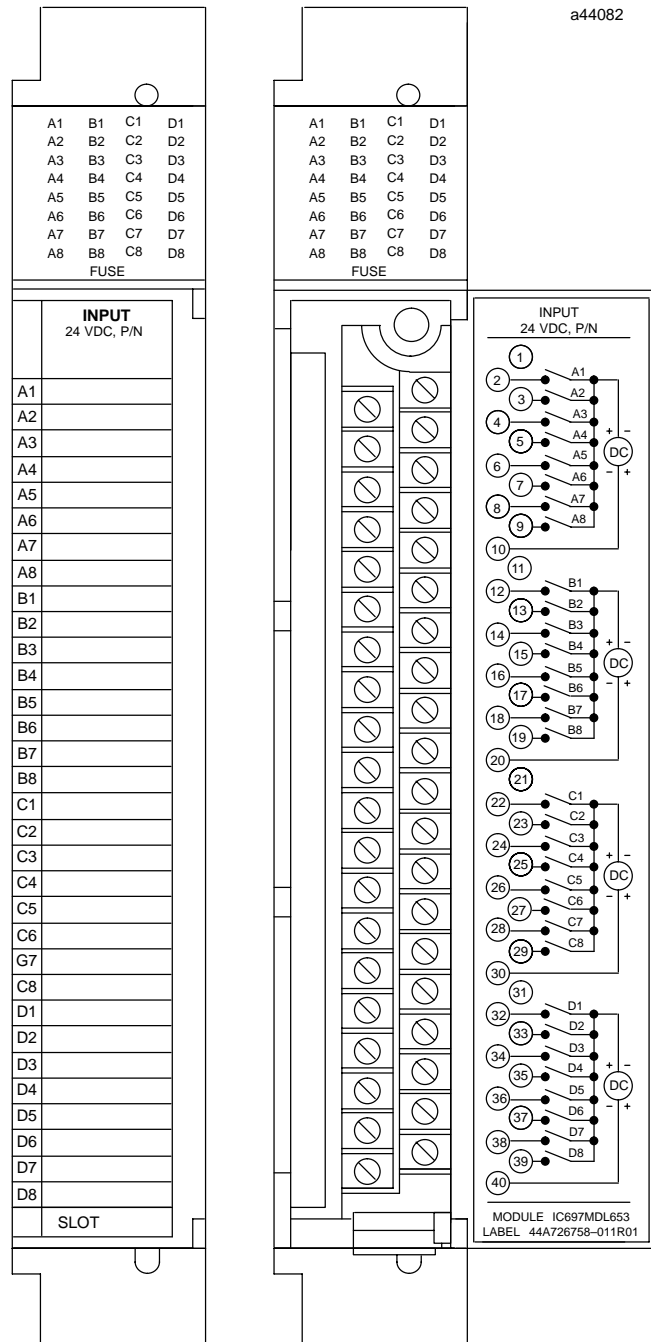

® IBM and PS/2 are registered trademarks of International Business Machines Corporation.

® MS-DOS, Windows, Windows 95, and Windows NT are registered trademarks of Microsoft Corporation.

GFK-0379F
August 1997

24 Volt DC Positive/Negative Logic, 32-Point Input Module

Operation - 24 Volt DC Positive/Negative Logic Input Module

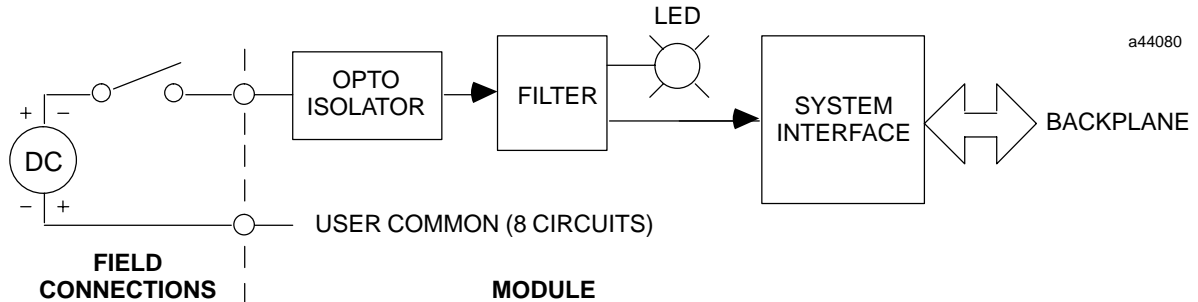

Figure 1. Block Diagram for IC697MDL653

Input Characteristics

This input module is designed to have both positive and negative logic characteristics in that it sinks or sources current from the input device to the user common. The input device is connected between the power bus and the module input as shown above.

This module is compatible with a wide variety of input devices, such as:

- Pushbuttons, limit switches, selector switches;
- Electronic proximity switches, both 2-wire and 3-wire.

In addition, inputs on this module may be directly driven by any IC697 PLC voltage compatible output module.

The input circuitry provides sufficient current to ensure reliable operation of the switching device. Input current is typically 10mA in the ON state, and can accept up to 2 mA leakage current in the OFF state without turning on.

3-wire proximity switches are easily applied, since they provide low voltage drop in the ON state and low leakage current in the OFF State.

2-wire proximity switches derive their power from the signal connections; thus both the ON state voltage and the OFF state leakage current are higher than for 3-wire devices. This module is designed to be com-

patible with many such 2-wire devices; however each device type must be carefully evaluated for compatibility in both the ON and OFF states.

To determine compatibility with a specific proximity switch, find the ON state characteristics of the switch in the diagram shown below. If that point falls to the left of the input load line, the ON state characteristics are compatible. As an example, the ON state requirements of a compatible proximity switch of 3mA at 5 volts drop are shown below.

OFF state compatibility is assured if the proximity switch leakage is less than 2mA with a module input voltage of 5 volts or less.

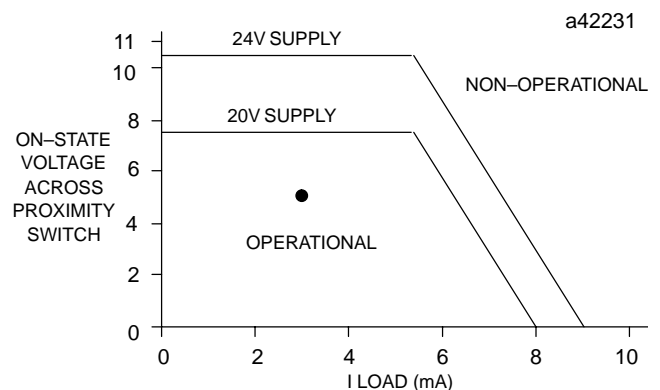

Figure 2. Proximity Switch Compatibility

24 Volt DC Positive/Negative Logic, 32-Point Input Module

GFK-0379F
August 1997

Input Filter Selection

With the IC697 PLC and certain other CPU options, this module may be configured to have either a 1mS or 10mS input filter. Configuration is on a module, not per point basis; all points have the same filter time. See the applicable *Programmable Controllers Reference Manual* for detailed information.

Interrupt

When used with the IC697 CPU, input point A1 may be configured to cause a CPU interrupt. Configuration allows the CPU to be interrupted on either the rising or falling edge of the signal transition. Interrupt response is not affected by input filter time selection. Refer to the applicable *Programmable Controllers Reference Manual* for detailed information.

Module Mechanical Keying

This module includes a mechanical key that prevents inadvertent substitution of one module type for another in a given slot. The key fits a uniquely shaped area on the board below the connector. Each module has a key packaged with it.

When the module is first installed, the key latches onto the backplane center rail. When the module is extracted, the key remains in the center rail, configuring the slot to accept only identical module types.

If it is necessary to change the module location in the rack after the key has been latched onto the center rail of the rack, the key can be removed by pushing it upward to unhook the latch while pulling it off the rail. It may then be reinserted onto the module and the module inserted into the rack in the desired location.

Note that in an IC697 PLC rack only the power supply can be placed in the leftmost rack position, and slot 1 (adjacent to the power supply) must always contain a CPU (in rack 0 - the CPU rack), or a Bus Receiver Module (in an expansion rack).

Field Wiring

The module is wired as shown in Figure 3. Since each group of eight inputs is isolated from the others, a wire from the power source to the power input terminal (10, 20, 30, or 40) for each group is required (pow-

er input terminals for each group are not connected inside the module).

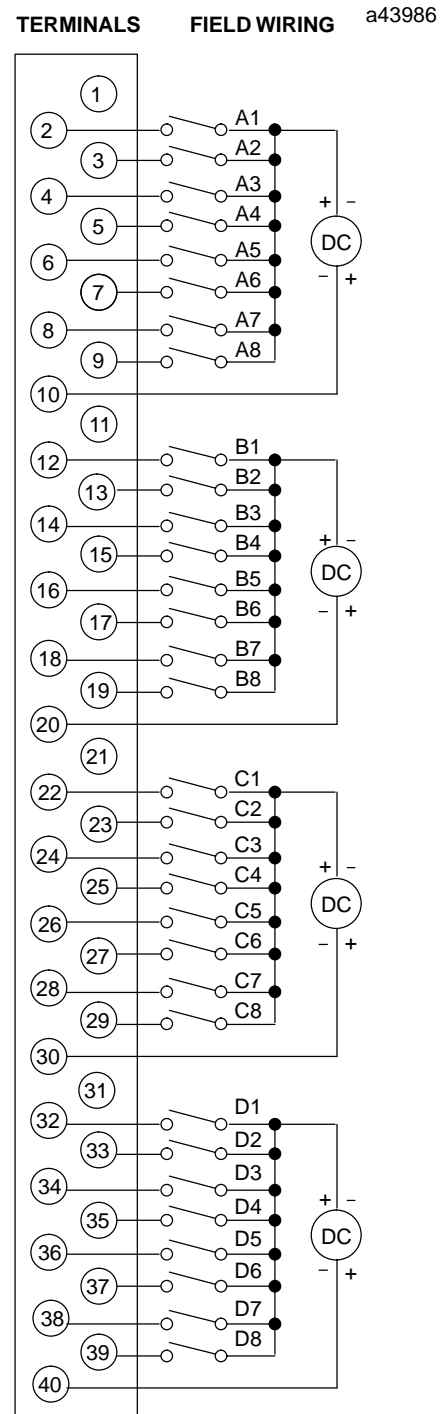

Figure 3. Field Wiring Connections for IC697MDL653

GFK-0379F
August 1997

24 Volt DC Positive/Negative Logic, 32-Point Input Module

Recommended Field Wiring Procedures

The following procedures are recommended when connecting field wiring to the detachable terminal

board on this input module. Module features referenced in the following procedures which are common to all IC697 I/O modules are illustrated in the following figure.

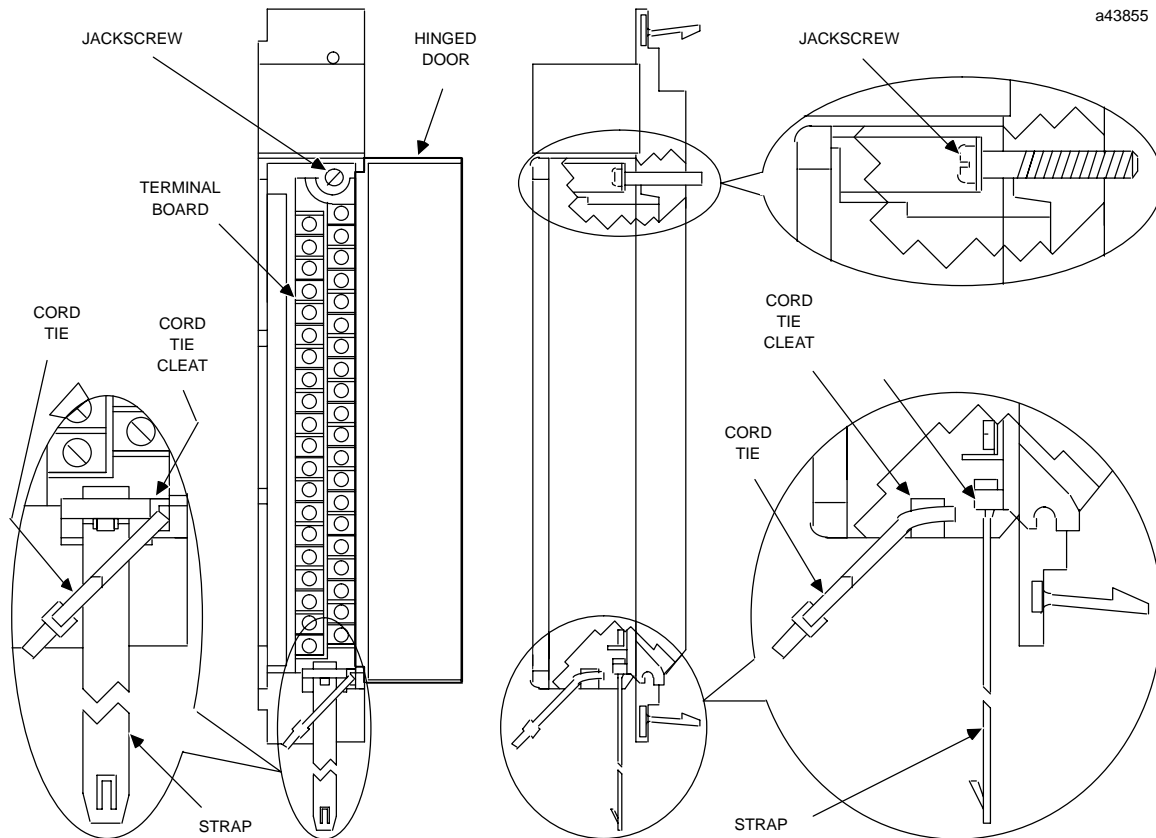

Figure 4. I/O Module Features

1. Turn off power before removing or installing terminal boards. Open the hinged door on the module to access a jackscrew which holds the terminal board securely in place. The detachable field wiring terminal board can now be removed from the module by turning the jackscrew counter-clockwise until it is fully disengaged.
2. To remove the terminal board, grasp the top of the terminal board and swing it outward.
3. The terminal board is designed to accept wire sizes from AWG #22 (0.36 mm^2) through AWG #14 (2.10 mm^2). It is important that when using AWG #14 (2.10 mm^2) wire for wiring all points, that a maximum insulation diameter of .135 inch (3.43mm) not be exceeded. To ensure proper connection, two wires may be terminated on any one terminal only if both wires are the same size.
4. The terminal board is designed to accept a maximum of (40) AWG #14 (2.10 mm^2) wires. If AWG #14 (2.10 mm^2) wires are to be used, then wire markers should be placed at least 8 inches (203 mm) from termination end to provide sufficient space for the hinged door to close.

Caution

Do not use the hinged door to remove the terminal board. The hinged door could be damaged if this is done.

24 Volt DC Positive/Negative Logic, 32-Point Input Module

GFK-0379F
August 1997

Figure 5. Removal of I/O Terminal Board

5. After completing connections to all modules in a rack, the wire bundle must be secured. To ensure that the wire bundle is secured properly, it is recommended that a cable tie be wrapped around the wire bundle and tightly secured through the cable tie cleat located at the lower right corner of the terminal board. For extremely large wire bundles, additional cable ties should be used.
6. A door label insert is included with each module to indicate circuit wiring information and provide space to record user circuit wiring identification. A slot is provided on the hinged door to allow for insertion of this label. If the label is difficult to insert, crease the scored edge before insertion. The outside label has a color coded stripe to allow quick identification of the module voltage type (blue: low voltage; red: high voltage).
7. After field wiring is completed, the terminal board should be securely fastened to the rack by inserting the terminal board strap (attached to each module) into the small rectangular slots in the bottom card guide grill on the rack. This strap not only secures

the terminal board to the rack, it also provides a way of identifying the wired terminal board with its correct mating rack slot location.

8. For adequate module ventilation, it is recommended that at least a 6 inch (152mm) clearance be allowed above and below the rack grill. Wire bundles should not obstruct the rack grill work.

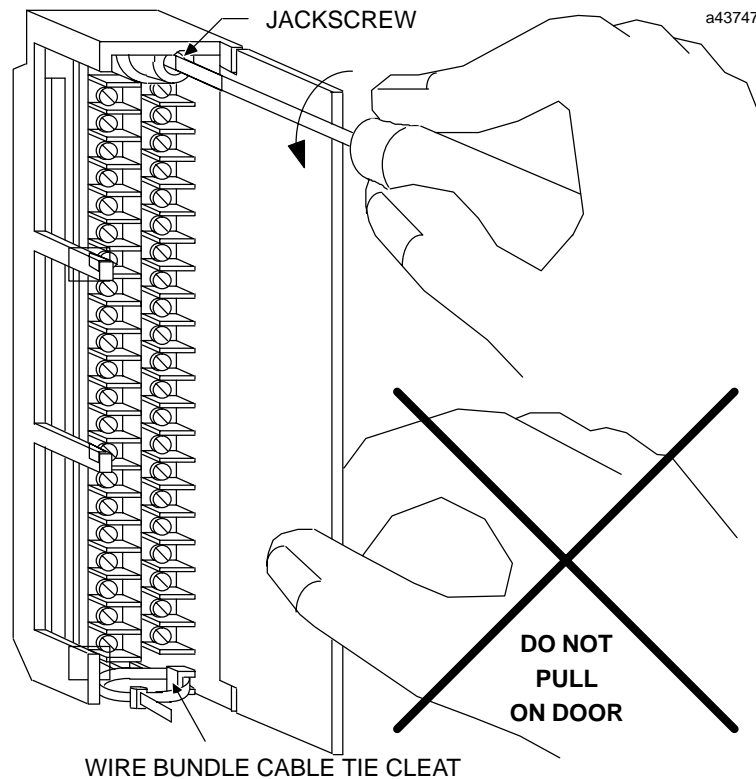
Removing an I/O Module

The instructions below should be followed when removing an I/O module from its slot in a rack.

- Grasp the board firmly at the top and bottom of the board cover with your thumbs on the front of the cover and your fingers on the plastic clips on the back of the cover.
- Squeeze the rack clips on the back of the cover with your fingers to disengage the clip from the rack rail and pull the board firmly to remove it from the backplane connector.
- Slide the board along the card guide and remove it from the rack.

GFK-0379F
August 1997

24 Volt DC Positive/Negative Logic, 32-Point Input Module

Table 1. Specifications for IC697MDL653 †

Rated Voltage:	24 volts DC
Inputs per Module:	32 (four groups of eight inputs each)
Isolation:	1500 volts - any input to backplane 500 volts between input groups
Input Voltage Range (V_s):	-3 to +30 volts DC
Input Current:	10mA (typical) at rated voltage
Input Impedance:	2.6K ohm, typical
Input Characteristics	
On-state Voltage:	13.5 volts to 30 volts
On-state Current:	6mA to 15mA
Off-state Voltage:	0 volts to 5 volts
Off-state Current:	0 to 2mA (2mA minimum at 5V input)
Filter Delay Time:	1mS or 10mS configurable
Current Required from 5V Bus:	0.30 amp
VME	System designed to support the VME standard C.1

† Refer to GFK-0867B, or later for product standards and general specifications. For installations requiring compliance to more stringent requirements (for example, FCC or European Union Directives), refer to *Installation Requirements for Conformance to Standards*.

Table 2. Ordering Information

Description	Catalog Number
Input Module, 24 Volt DC Positive/Negative Logic, 32 Points	IC697MDL653

Note: For Conformal Coat option, or Low Temperature Testing option please consult the factory for price and availability.

Discrete Input Modules

IC697MDL652

GFK-0378F
August 1997

12 Volt DC Positive/Negative Logic, 32-Point Input Module

Features

- 32 Points - Four isolated groups of 8 points each
- Positive/Negative Logic Compatibility
- Proximity switch compatible
- Input filter selectable* - 1mS or 10mS
- One input configurable as interrupt*

* These features are available for all IC697 Programmable Logic Controllers (PLC). They may not be available when this module is used with other types of PLCs. See the applicable *Programming Software User's Manual* for details.

Functions

The **12 Volt DC Positive/Negative Logic Input Module** provides 32 input points in four isolated groups of eight points each. The input current-voltage characteristics meet IEC standard (type 1) specifications.

LED indicators which give the ON-OFF status of each point on the logic (PLC) side of the circuit are included at the top of the module.

The module is mechanically keyed to ensure correct replacement with a similar type in the field. I/O references are user configurable without the use of jumpers or DIP switches on the module.

Configuration is done using the configuration function of the MS-DOS® or Windows® programming software running on Windows® 95 or Windows NT® over Ethernet TCP/IP or through the SNP port. The Programming Software configuration function is installed on the programming device. The programming device can be an IBM® XT, AT, PS/2® or compatible Personal Computer.

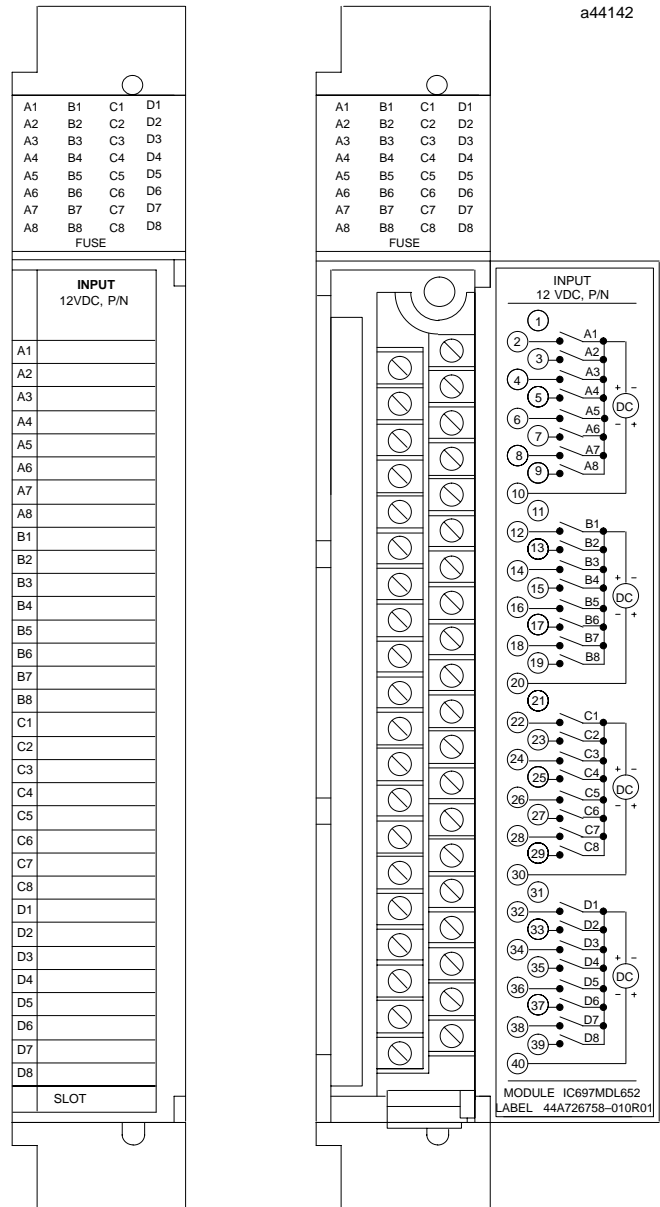

® IBM and PS/2 are registered trademarks of International Business Machines Corporation.

® MS-DOS, Windows, Windows 95, and Windows NT are registered trademarks of Microsoft Corporation.

GFK-0378F
August 1997

12 Volt DC Positive/Negative Logic, 32-Point Input Module

Operation - 12 Volt DC Pos/Neg Input Module

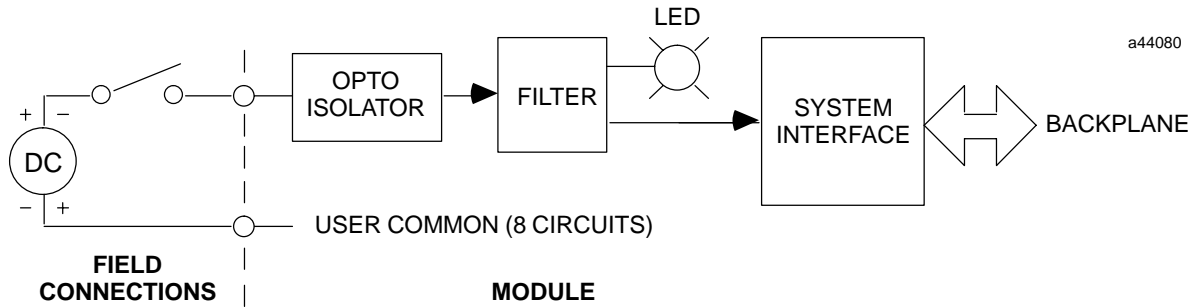

Figure 1. Block Diagram for IC697MDL652

Input Characteristics

This input module is designed to have both positive and negative logic characteristics - it sinks or sources current from the input device to the user common. The input device is connected between the power bus and the module input as shown above.

This module is compatible with a wide variety of input devices, such as:

- Pushbuttons, limit switches, selector switches;
- Electronic proximity switches, both 2-wire and 3-wire.

In addition, inputs on this module may be directly driven by any IC697 programmable controller voltage compatible output module.

The input circuitry provides sufficient current to ensure reliable operation of the switching device. Input current is typically 10mA in the ON state, and can accept up to 2 mA leakage current in the OFF state without turning on.

3-wire proximity switches are easily applied, since they provide low voltage drop in the ON state and low leakage current in the OFF State.

2-wire proximity switches derive their power from the signal connections; thus both the ON state voltage and the OFF state leakage current are higher than for 3-wire devices. This module is designed to be compatible with many such 2-wire devices; however each device type must be carefully evaluated for compatibility in both the ON and OFF states.

To determine compatibility with a specific proximity switch, find the ON state characteristics of the switch in the diagram shown below. If that point falls to the left of the input load line, the ON state characteristics are compatible. As an example, the ON state requirements of a compatible proximity switch of 3mA at 5 volts drop are shown below.

OFF state compatibility is assured if the proximity switch leakage is less than 2mA with a module input voltage of 2.5 volts or less.

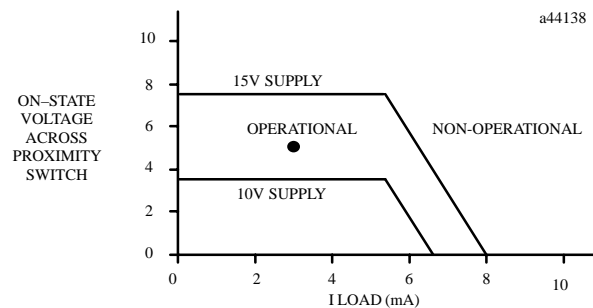

Figure 2. Proximity Switch Compatibility

Input Filter Selection

With the IC697 programmable controller and certain other CPU options, this module may be configured to have either a 1mS or 10mS input filter. Configuration is on a module, not per point basis; all points have the same filter time. See the applicable *Programmable Controller Installation Manual* for detailed information.

12 Volt DC Positive/Negative Logic, 32-Point Input Module

GFK-0378F
August 1997

Interrupt

When used with the IC697 CPU, input point A1 may be configured to cause a CPU interrupt. Configuration allows the CPU to be interrupted on either the rising or falling edge of the signal transition. Interrupt response is not affected by input filter time selection. Refer to the applicable *Programmable Controller Reference Manual* for detailed information.

Module Mechanical Keying

This module includes a mechanical key that prevents inadvertent substitution of one module type for another in a given slot. The key fits a uniquely shaped area on the board below the connector. Each module has a key packaged with it.

When the module is first installed, the key latches onto the backplane center rail. When the module is extracted, the key remains in the center rail, configuring the slot to accept only identical module types.

If it is necessary to change the module location in the rack after the key has been latched onto the center rail of the rack, the key can be removed by pushing it upward to unhook the latch while pulling it off the rail. It may then be reinserted onto the module and the module inserted into the rack in the desired location.

Note that in an IC697 PLC rack only the power supply can be placed in the leftmost rack position, and slot 1 (adjacent to the power supply) must always contain a CPU (in rack 0 - the CPU rack), or a Bus Receiver Module (in an expansion rack).

Field Wiring

The module is wired as shown in Figure 3. Since each group of eight inputs is isolated from the others, a wire from the power source to the power input terminal (10, 20, 30, or 40) for each group is required (power input terminals for each group are not connected inside the module).

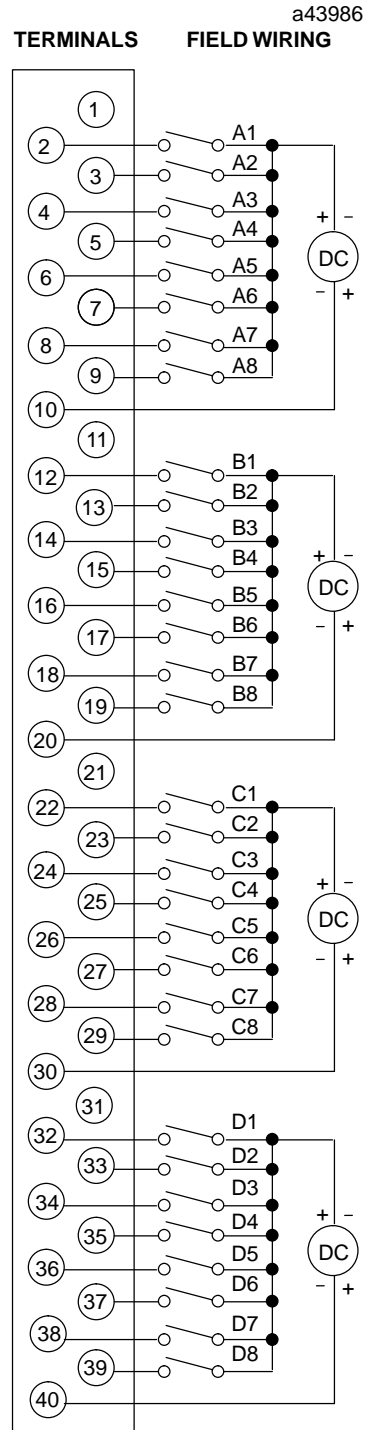

Figure 3. Field Wiring Connections

GFK-0378F
August 1997

12 Volt DC Positive/Negative Logic, 32-Point Input Module

Recommended Field Wiring Procedures

The following procedures are recommended when connecting field wiring to the detachable terminal board on this input

module. Module features referenced in the following procedures which are common to all IC697 I/O modules are illustrated in the following figure.

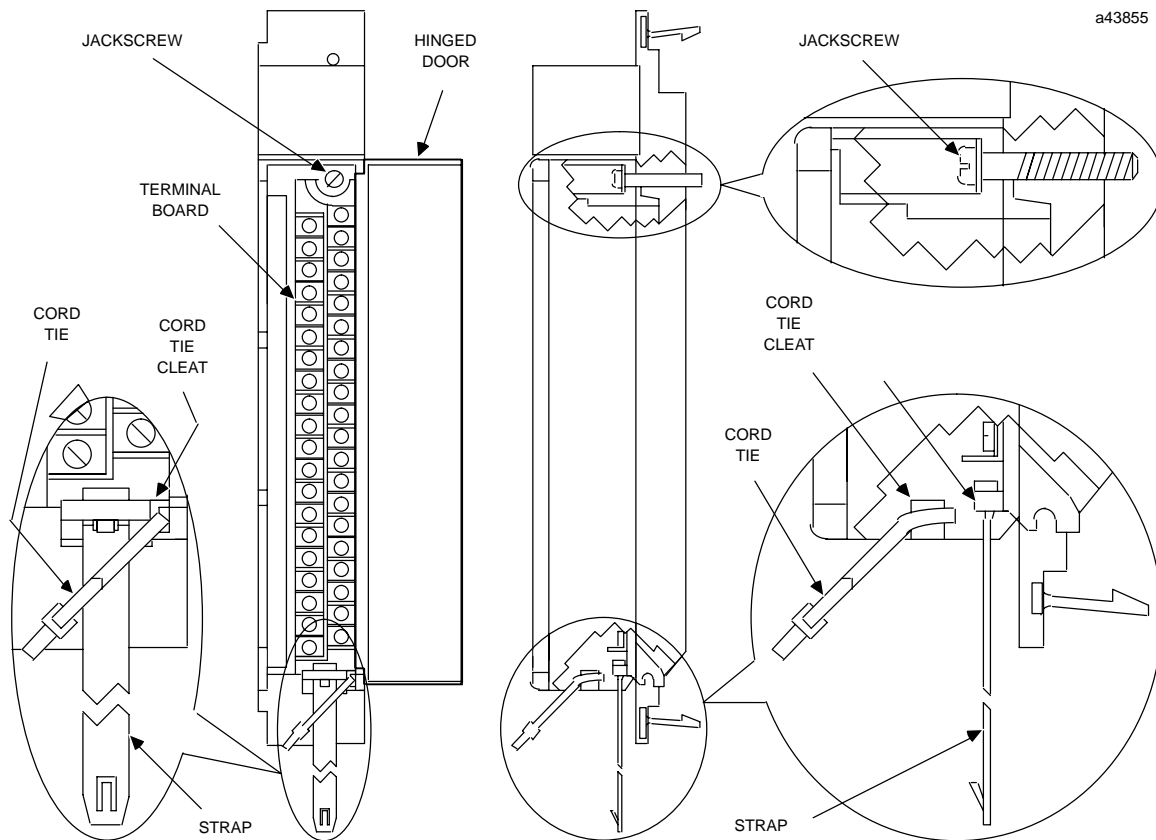

Figure 4. I/O Module Features

1. Turn off power before removing or installing terminal boards. Open the hinged door on the module to access a jackscrew which holds the terminal board securely in place. The detachable field wiring terminal board can now be removed from the module by turning the jackscrew counter-clockwise until it is fully disengaged.
2. To remove the terminal board, grasp the top of the terminal board and swing it outward as shown in Figure 5.
3. The terminal board is designed to accept wire sizes from AWG #22 (0.36 mm²) through AWG #14 (2.10 mm²). It is important that when using AWG #14 (2.10 mm²) wire for wiring all points, that a maximum insulation diameter of .135 inch (3.43mm) not be exceeded. To ensure proper connection, two wires may be terminated on any one terminal only if both wires are the same size.
4. The terminal board is designed to accept a maximum of (40) AWG #14 (2.10 mm²)wires. If AWG #14 (2.10 mm²) wires are to be used, then wire markers should be placed at least 8 inches (203 mm) from termination end to provide sufficient space for the hinged door to close.

Caution

Do not use the hinged door to remove the terminal board. The hinged door could be damaged if this is done.

12 Volt DC Positive/Negative Logic, 32-Point Input Module

GFK-0378F
August 1997

Figure 5. Removal of I/O Terminal Board

5. After completing connections to all modules in a rack, the wire bundle must be secured. To ensure that the wire bundle is secured properly, it is recommended that a cable tie be wrapped around the wire bundle and tightly secured through the cable tie cleat located at the lower right corner of the terminal board. For extremely large wire bundles, additional cable ties should be used.
6. A door label insert is included with each module to indicate circuit wiring information and provide space to record user circuit wiring identification. A slot is provided on the hinged door to allow for insertion of this label. If the label is difficult to insert, crease the scored edge before insertion. The outside label has a color coded stripe to allow quick identification of the module voltage type (blue: low voltage; red: high voltage).
7. After field wiring is completed, the terminal board should be securely fastened to the rack by inserting the terminal board strap (attached to each module) into the small rectangular slots in the bottom card guide grill on the rack. This strap not only secures the terminal board to the rack, it also provides a way of identifying the wired terminal board with its correct mating rack slot location.
8. For adequate module ventilation, it is recommended that at least a 6 inch (152mm) clearance be allowed above and below the rack grill. Wire bundles should not obstruct the rack grill work.

Removing an I/O Module

The instructions below should be followed when removing an I/O module from its slot in a rack.

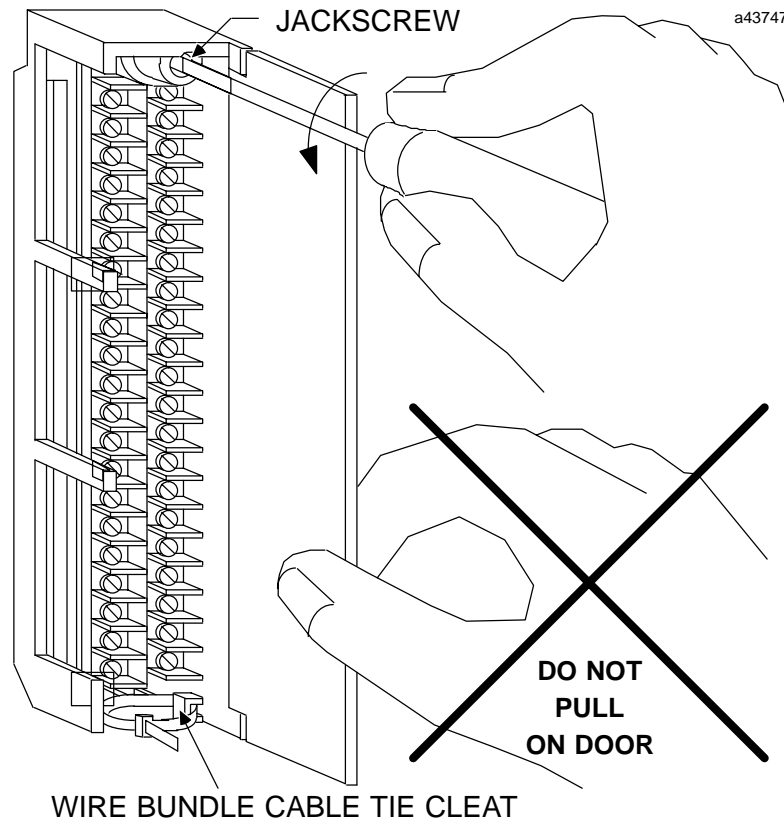
- Grasp the board firmly at the top and bottom of the board cover with your thumbs on the front of the cover and your fingers on the plastic clips on the back of the cover.
- Squeeze the rack clips on the back of the cover with your fingers to disengage the clip from the rack rail and pull the board firmly to remove it from the backplane connector.
- Slide the board along the card guide and remove it from the rack.

GFK-0378F
August 1997

12 Volt DC Positive/Negative Logic, 32-Point Input Module

Table 1. Specifications for IC697MDL652 †

Rated Voltage:	12 volts DC
Inputs per Module:	32 (four groups of eight inputs each)
Isolation:	1500 volts - any input to backplane 500 volts between input groups
Input Voltage Range (V_I):	-2.5 to +15 volts DC
Input Current:	4.7mA (typical) at rated voltage
Input Impedance:	1.12K ohm, typical
Input Characteristics	
On-state Voltage:	7.5 volts to 15 volts
On-state Current:	6mA to 15mA
Off-state Voltage:	0 volts to 2.5 volts
Off-state Current:	0 to 2.5mA (2mA minimum at 2.5V input)
Filter Delay Time:	1mS or 10mS configurable
Current Required from 5V Bus:	0.30 amp
VME	System designed to support the VME standard C.1

† Refer to GFK-0867B, or later for product standards and general specifications. For installations requiring compliance to more stringent requirements (for example, FCC or European Union Directives), refer to *Installation Requirements for Conformance to Standards*.

Table 2. Ordering Information

Description	Catalog Number
Input Module, 12 Volt DC Positive/Negative Logic, 32 Points	IC697MDL652

Note: For Conformal Coat option, or Low Temperature Testing option please consult the factory for price and availability.

Discrete Input Modules

IC697MDL654

GFK-0380G
August 1997

48 Volt DC Positive/Negative Logic, 32-Point Input Module

Features

- 32 Points - Four isolated groups of 8 points each
- Positive/Negative Logic Compatibility
- Proximity switch compatible
- Input filter selectable* - 1 ms or 10 ms
- One input configurable as interrupt*

* These features are available for all IC697 Programmable Logic Controllers (PLC). They may not be available when this module is used with other types of PLCs. See the applicable *Programmable Controller Reference Manual* for details.

Functions

The 48 Volt DC Pos/Neg Input Module provides 32 input points in four isolated groups of eight points each. The input current-voltage characteristics meet IEC standard (type 1) specifications.

LED indicators which give the ON-OFF status of each point on the logic (PLC) side of the circuit are included at the top of the module.

The module is mechanically keyed to ensure correct replacement with a similar type in the field. I/O references are user configurable without the use of jumpers or DIP switches on the module.

Configuration is done using the configuration function of the MS-DOS® or Windows® programming software running on Windows® 95 or Windows NT® over Ethernet TCP/IP or through the SNP port. The Programming Software configuration function is installed on the programming device. The programming device can be an IBM® XT, AT, PS/2® or compatible Personal Computer.

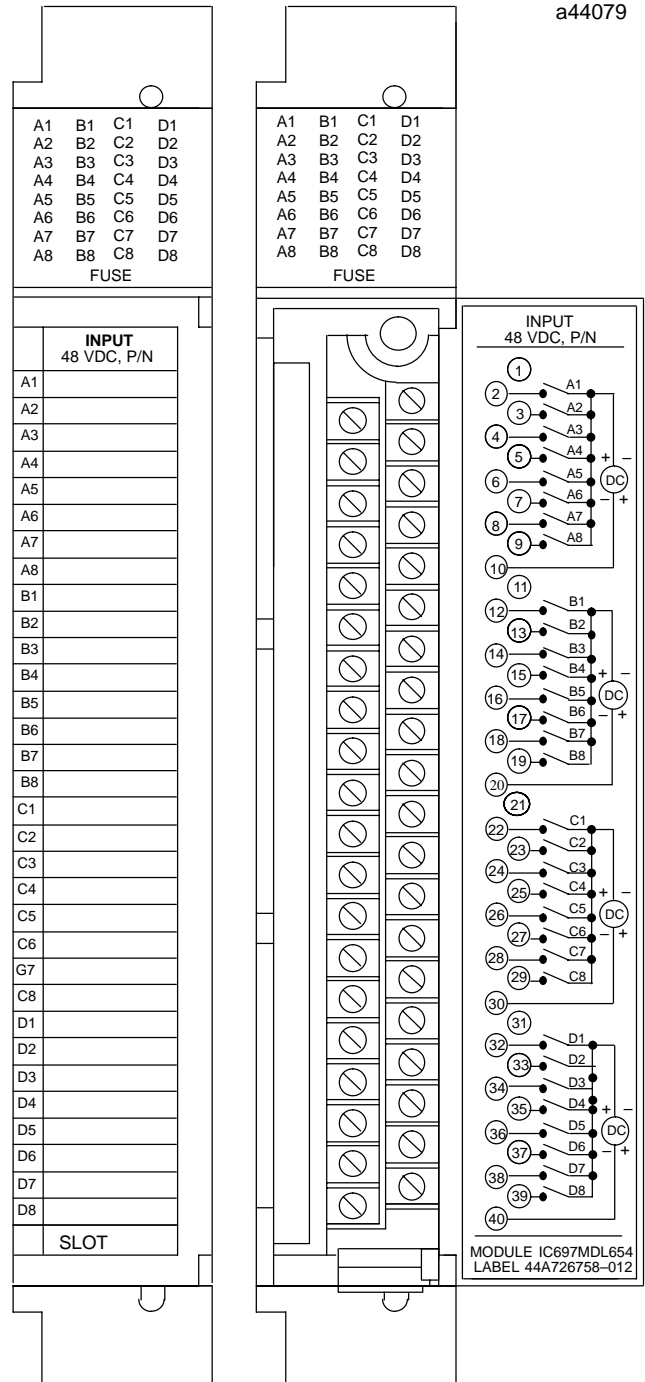

© IBM and PS/2 are registered trademarks of International Business Machines Corporation.

© MS-DOS, Windows, Windows 95, and Windows NT are registered trademarks of Microsoft Corporation.

GFK-0380G
August 1997

48 Volt DC Positive/Negative Logic, 32-Point Input Module

Operation - 48 Volt DC Pos/Neg Input Module

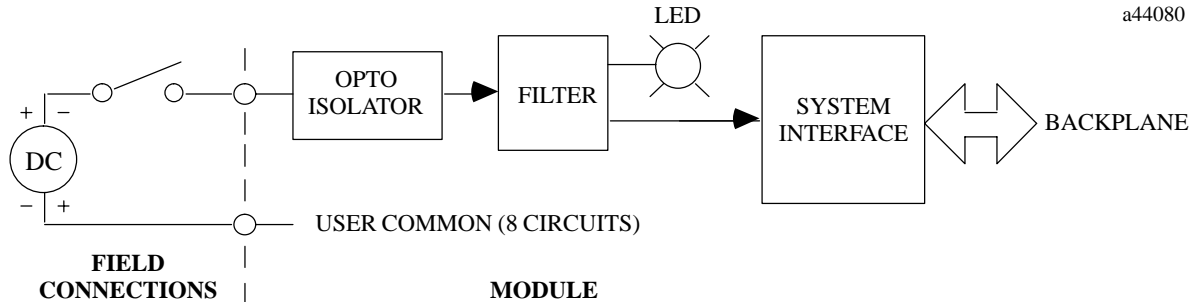

Figure 1. Block Diagram for IC697MDL654

Input Characteristics

This input module is designed to have both positive and negative logic characteristics - it sinks or sources current from the input device to the user common. The input device is connected between the power bus and the module input as shown above.

This module is compatible with a wide variety of input devices, such as:

- Pushbuttons, limit switches, selector switches;
- Electronic proximity switches, both 2-wire and 3-wire.

In addition, inputs on this module may be directly driven by any IC697 PLC voltage compatible output module.

The input circuitry provides sufficient current to ensure reliable operation of the switching device. Input current is typically 4.7mA in the ON state, and can accept up to 2 mA leakage current in the OFF state without turning on.

3-wire proximity switches are easily applied, since they provide low voltage drop in the ON state and low leakage current in the OFF State.

2-wire proximity switches derive their power from the signal connections; thus both the ON state voltage and the OFF state leakage current are higher than for 3-wire devices. This module is designed to be compatible with many such 2-wire devices; however each device type must be carefully evaluated for compatibility in both the ON and OFF states.

To determine compatibility with a specific proximity switch, find the ON state

characteristics of the switch in the diagram shown below. If that point falls to the left of the input load line, the ON state characteristics are compatible. As an example, the ON state requirements of a compatible proximity switch of 3mA at 5 volts drop are shown below.

OFF state compatibility is assured if the proximity switch leakage is less than 2mA with a module input voltage of 5 volts or less.

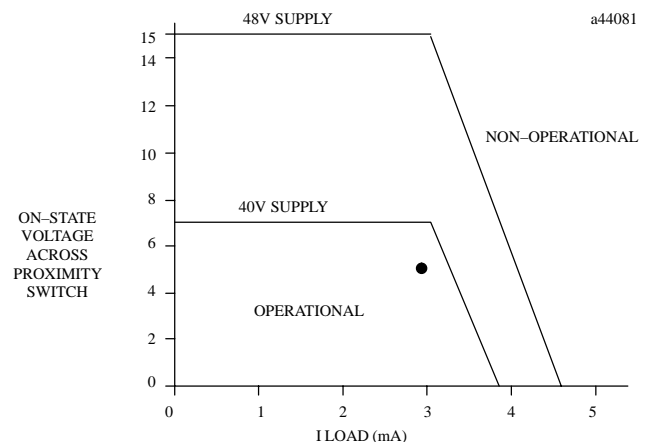

Figure 2. Proximity Switch Compatibility

Input Filter Selection

With the IC697 PLC and certain other CPU options, this module may be configured to have either a 1mS or 10mS input filter. Configuration is on a module, not per point basis; all points have the same filter time. See the applicable *Programmable Controller Reference Manual* for detailed information.

48 Volt DC Positive/Negative Logic, 32-Point Input Module

GFK-0380G
August 1997

Interrupt

When used with the IC697 CPU, input point A1 may be configured to cause a CPU interrupt. Configuration allows the CPU to be interrupted on either the rising or falling edge of the signal transition. Interrupt response is not affected by input filter time selection. Refer to the applicable *Programmable Controller Reference Manual* for detailed information.

Module Mechanical Keying

This module includes a mechanical key that prevents inadvertent substitution of one module type for another in a given slot. The key fits a uniquely shaped area on the board below the connector. The key is included with each module.

When the module is first installed, the key latches onto the backplane center rail. When the module is extracted, the key remains in the center rail, configuring the slot to accept only identical module types.

If it is necessary to change the module location in the rack after the key has been latched onto the center rail of the rack, the key can be removed by pushing it upward to unhook the latch while pulling it off the rail. It may then be reinserted onto the module and the module inserted into the rack in the desired location. Note that only the power supply can be placed in the leftmost rack position.

Field Wiring

The module is wired as shown in the illustration on the right of this page. Since each group of eight inputs is isolated from the others, a wire from the power source to the power input terminal for each group (terminal number 10, 20, 30, or 40) is required (power input terminals for each group are not connected inside the module).

The detachable field wiring terminal board will accept wire sizes ranging from #22 (0.36 mm²) through #14 (2.10 mm²). Two wires may be terminated on a given lug if both wires are the same size. There is room for a bundle of forty #14 (2.10 mm²) wires to be routed out through the terminal board cavity.

The wire bundle can be secured to the terminal board by passing a cable tie through a cleat located at the lower corner of the terminal board.

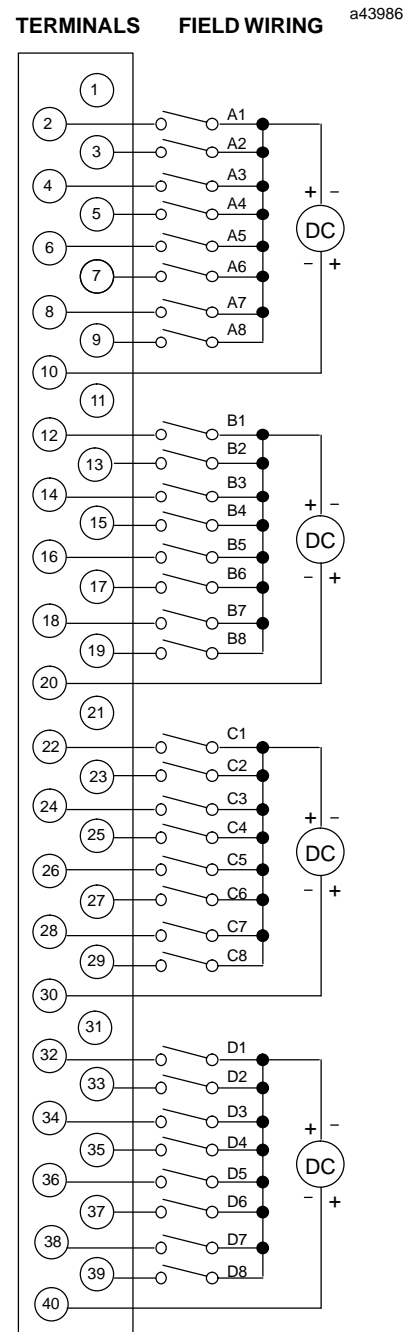

Figure 3. Field Wiring Connections

GFK-0380G
August 1997

48 Volt DC Positive/Negative Logic, 32-Point Input Module

Recommended Field Wiring Procedures

The following procedures are recommended when connecting field wiring to the detachable terminal board on this input

module. Module features referenced in the following procedures which are common to all I/O modules for the IC697 PLC are illustrated in the following figure.

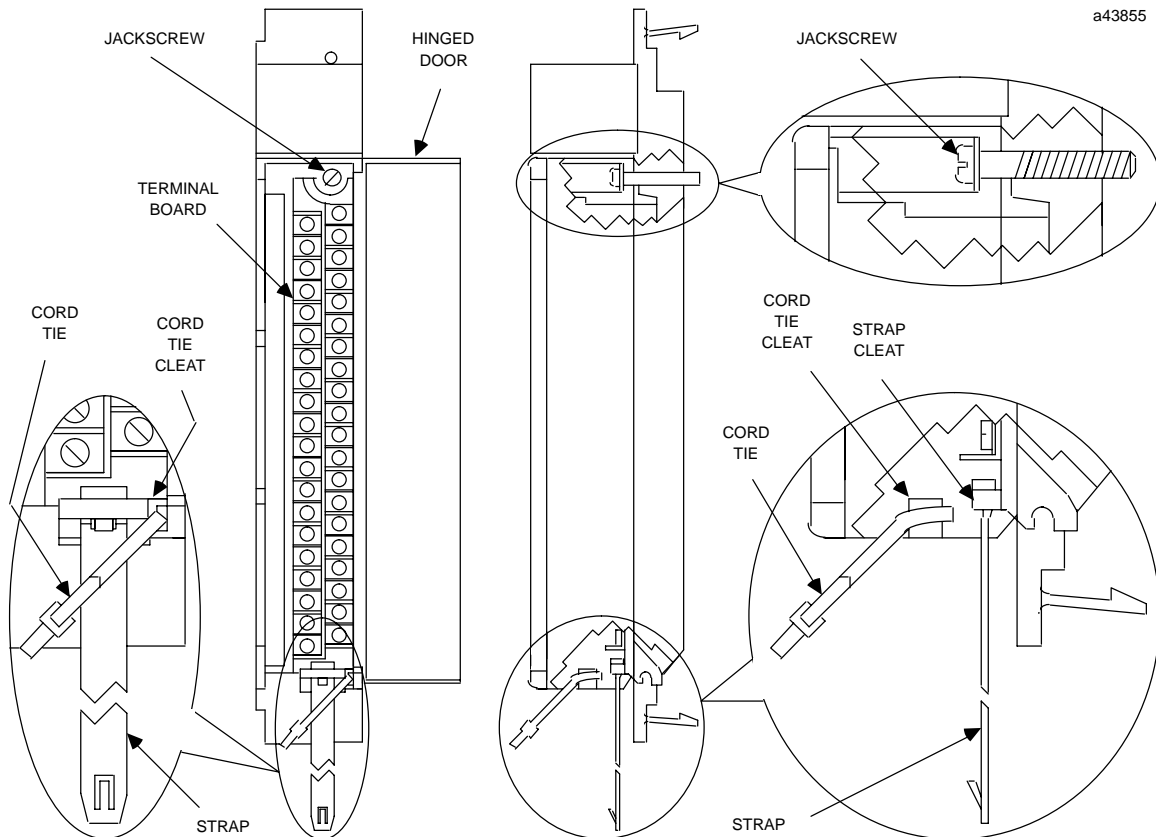

Figure 4. I/O Module Features

1. Turn off power before removing or installing terminal boards. Open the hinged door on the module to access a jackscrew which holds the terminal board securely in place. The detachable field wiring terminal board can now be removed from the module by turning the jackscrew counter-clockwise until it is fully disengaged.
2. To remove the terminal board, grasp the top of the terminal board and swing it outward as shown in Figure 5.
3. The terminal board is designed to accept wire sizes ranging from AWG #22 (0.36 mm^2) through AWG #14 (2.10 mm^2). It is important that when using AWG #14 (2.10 mm^2) wire for wiring all points, that a maximum insulation diameter of .135 inch not be exceeded. To ensure proper connection, two wires may be terminated on any one terminal only if both wires are the same size.
4. The terminal board is designed to accept a maximum of (40) AWG #14 (2.10 mm^2) wires. If AWG #14 (2.10 mm^2) wires are to be used, then wire markers should be placed at least 8 inches (203 mm) from termination end to provide sufficient space for the hinged door to close.

Caution

Do not use the hinged door to remove the terminal board. The hinged door could be damaged if this is done.

48 Volt DC Positive/Negative Logic, 32-Point Input Module

GFK-0380G
August 1997

Figure 5. Removal of I/O Terminal Board

5. After completing connections to all modules in a rack, the wire bundle must be secured. To ensure that the wire bundle is secured properly, it is recommended that a cable tie be wrapped around the wire bundle and tightly secured through the cable tie cleat located at the lower right corner of the terminal board. For extremely large wire bundles, additional cable ties should be used.
6. A door label insert is included with each module to indicate circuit wiring information and provide space to record user circuit wiring identification. A slot is provided on the hinged door to allow for insertion of this label. If the label is difficult to insert, crease the scored edge before insertion. The outside label has a color coded stripe to allow quick identification of the module voltage type (blue: low voltage; red: high voltage).
7. After field wiring is completed, the terminal board should be securely fastened to the rack by inserting the terminal board strap (attached to each module) into the small rectangular slots in the bottom card guide grill on the rack. This strap not only secures the terminal board to the rack, it also

provides a way of identifying the wired terminal board with its correct mating rack slot location.

8. For adequate module ventilation, it is recommended that at least a 6 inch (152 mm) clearance be allowed above and below the rack grill. Wire bundles should not obstruct the rack grill work.

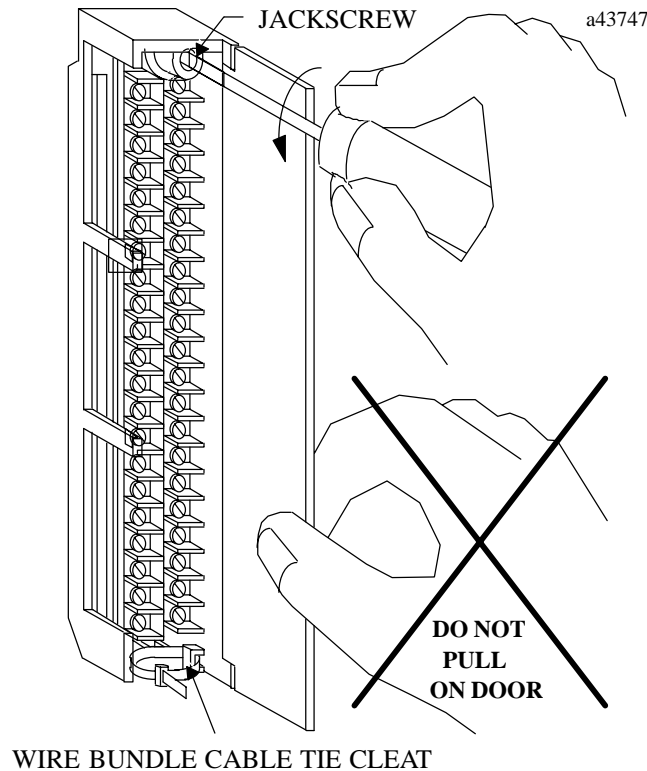
Removing an I/O Module

The instructions below should be followed when removing an I/O module from its slot in a rack.

- Grasp the board firmly at the top and bottom of the board cover with your thumbs on the front of the cover and your fingers on the plastic clips on the back of the cover.
- Squeeze the rack clips on the back of the cover with your fingers to disengage the clip from the rack rail and pull the board firmly to remove it from the backplane connector.
- Slide the board along the card guide and remove it from the rack.

GFK-0380G
August 1997

48 Volt DC Positive/Negative Logic, 32-Point Input Module

Table 1. Specifications for IC697MDL654 †

Rated Voltage:	48 volts DC
Inputs per Module:	32 (four groups of eight inputs each)
Isolation:	1500 volts RMS - any input to backplane 500 volts RMS between input groups
Input Voltage Range (V_s)	-3 to +56 volts DC
Input Current:	4.7mA (typical) at rated voltage
Input Impedance:	10.3K ohm, typical
Input Characteristics-	
On-state Voltage:	33 volts to 56 volts
Off-state Current	3mA to 7mA
Off-state Voltage:	0 volts to 10 volts
Off-state Current:	0 to 2mA (2mA minimum at 5V input)
Filter Delay Time:	1 ms or 10 ms configurable
Current Required from 5VDC backplane bus:	0.30amps
VME	System designed to support the VME standard C.1

† Refer to GFK-0867B, or later for product standards and general specifications. For installations requiring compliance to more stringent requirements (for example, FCC or European Union Directives), refer to *Installation Requirements for Conformance to Standards*.

Table 2. Ordering Information

Description	Catalog Number
Input Module: 48 Volt DC Positive/Negative Logic, 32 Points	IC697MDL654

Note: For Conformal Coat option, or Low Temperature Testing option please consult the factory for price and availability.

Discrete Input Modules

IC697MDL640

GFK-0719D
August 1997

125 Volt DC Positive/Negative Logic, 16-Point Input Module

Features

- 16 Points - Four isolated groups of four points each
- Positive/Negative Logic Compatibility
- Proximity switch compatible
- Input filter selectable* - 1 ms or 10 ms
- One input configurable as interrupt*

* These features are available for all IC697 Programmable Logic Controllers (PLC). They may not be available when this module is used with other types of PLCs. See the applicable *Programmable Controller Reference Manual* for details.

Functions

The 125 Volt DC Positive/Negative Input Module provides 16 input points in four isolated groups of four points each. The input current-voltage characteristics meet IEC standard (type 1) specifications.

LED indicators which give the ON-OFF status of each point on the logic (PLC) side of the circuit are included at the top of the module.

The module is mechanically keyed to ensure correct replacement with a similar type in the field. I/O references are user configurable without the use of jumpers or DIP switches on the module.

Configuration is done using the configuration function of the MS-DOS® or Windows® programming software running on Windows® 95 or Windows NT® over Ethernet TCP/IP or through the SNP port. The Programming Software configuration function is installed on the programming device. The programming device can be an IBM® XT, AT, PS/2® or compatible Personal Computer.

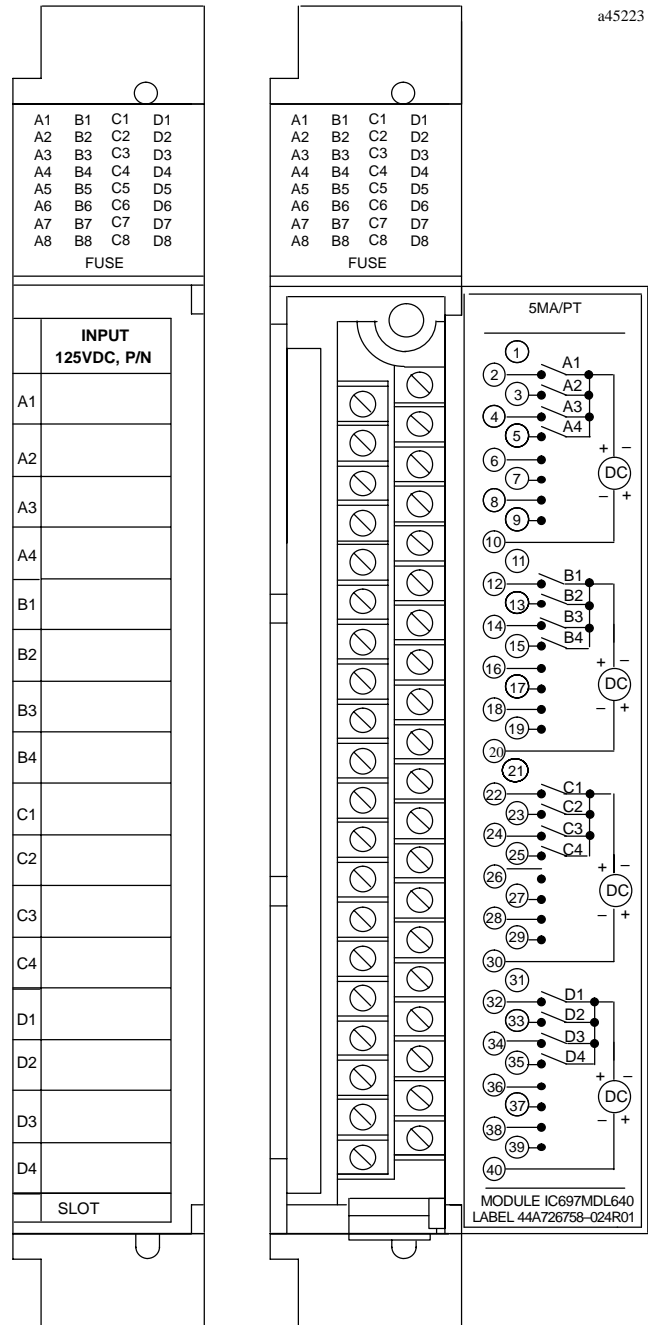

a45223

© IBM and PS/2 are registered trademarks of International Business Machines Corporation.

© MS-DOS, Windows, Windows 95, and Windows NT are registered trademarks of Microsoft Corporation.

Operation of the 125 Volt DC Pos/Neg Input Module

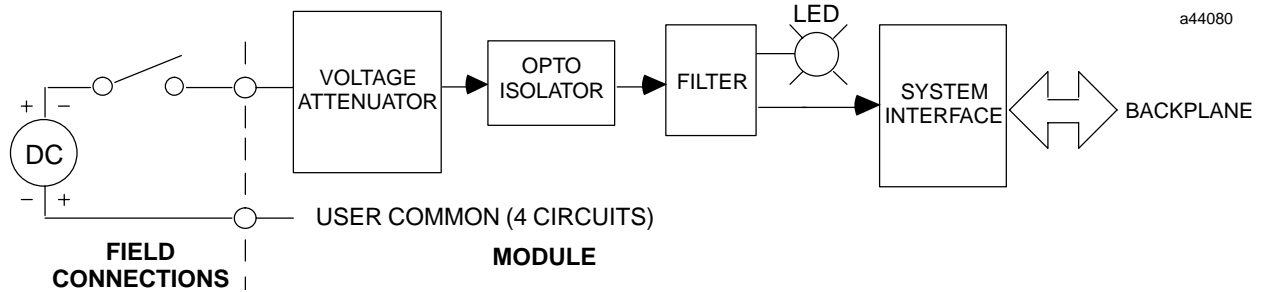

Figure 1. Block Diagram for IC697MDL640

Input Characteristics

This input module is designed to have both positive and negative logic characteristics - it sinks or sources current from the input device to the user common. The input device is connected between the power bus and the module input as shown above.

This module is compatible with a wide variety of input devices, such as:

- Pushbuttons, limit switches, selector switches;
- Electronic proximity switches, both 2 and 3-wire.

In addition, inputs on this module may be directly driven by any IC697 PLC voltage compatible output module.

The input circuitry provides sufficient current to ensure reliable operation of the switching device. Input current is typically 5mA in the ON state, and can accept up to 2 mA leakage current in the OFF state without turning on.

3-wire proximity switches are easily applied, since they provide low voltage drop in the ON state and low leakage current in the OFF State.

2-wire proximity switches derive their power from the signal connections; thus both the ON state voltage and the OFF state leakage current are higher than for 3-wire devices. This module is designed to be compatible with many such 2-wire devices; however each device type must be carefully evaluated for compatibility in both the ON and OFF states.

To determine compatibility with a specific proximity switch, find the ON state characteristics of the switch in the diagram shown below. If that point falls to the left of the input load line, the ON state characteristics are compatible. As an example, the ON state requirements of a compatible proximity switch of 3mA at 5 volts drop are shown below. OFF state compatibility is assured if

the proximity switch leakage is less than 2mA with a module input voltage of 35 volts or less.

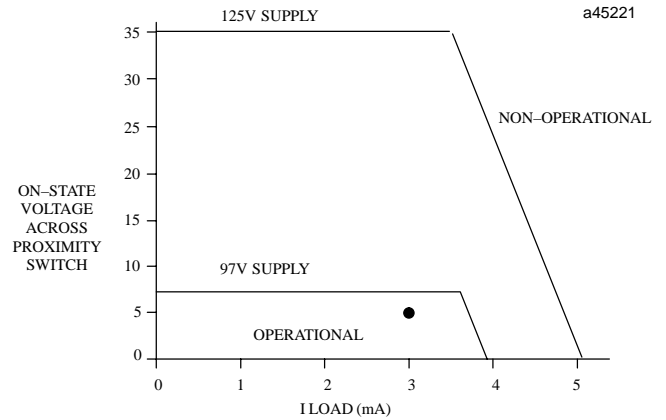

Figure 2. Proximity Switch Compatibility

Thermal Derating

If this input module is operated above the normal input voltage of 125 VDC, it may be necessary to derate the number of input points used per group as shown below.

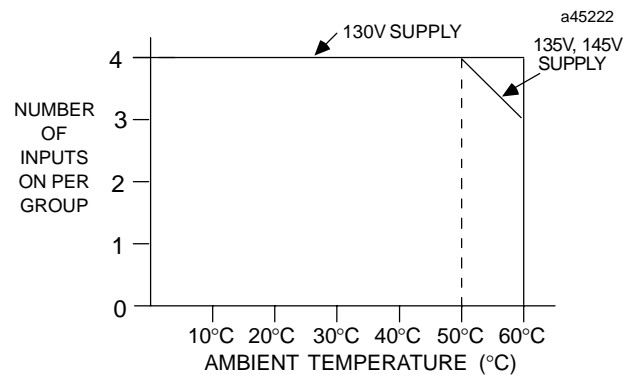

Figure 3. Input Points vs. Temperature

125 Volt DC Positive/Negative Logic, 16-Point Input Module

GFK-0719D
August 1997

a47014

For example, if an input voltage of 130 volts DC or less is used to activate the input module, no derating is required. However, if input voltages greater than or equal to 135 volts DC are used, no more than 3 inputs per group should be simultaneously activated at ambient temperatures greater than 50°C (122°F).

Input Filter Selection

With the IC697 PLC and certain other CPU options, this module may be configured to have either a 1mS or 10mS input filter. Configuration is on a module, not per point basis; all points have the same filter time. See the applicable *Programmable Controller Reference Manual* for detailed information.

Interrupt

When used with the IC697 CPU, input point A1 may be configured to cause a CPU interrupt. Configuration allows the CPU to be interrupted on either the rising or falling edge of the signal transition. Interrupt response is not affected by input filter time selection. Refer to the applicable *Programmable Controller Reference Manual* for detailed information.

Module Mechanical Keying

This module includes a mechanical key that prevents inadvertent substitution of one module type for another in a given slot. The key fits a uniquely shaped area on the board below the connector. The key is included with each module.

When the module is first installed, the key latches onto the backplane center rail. When the module is extracted, the key remains in the center rail, configuring the slot to accept only identical module types.

If it is necessary to change the module location in the rack after the key has been latched onto the center rail, the key can be removed by pushing it upward to unhook the latch while pulling it off the rail. It may then be reinserted onto the module and the module inserted into the rack in the desired location. Note that only the power supply can be placed in the leftmost rack position.

Field Wiring

The module is wired as shown in the following illustration. Since each group of four inputs is isolated from the others, a wire from the power source to the power input terminal for each group (terminal number 10, 20, 30, or 40) is required (power input terminals for each group are not connected inside the module).

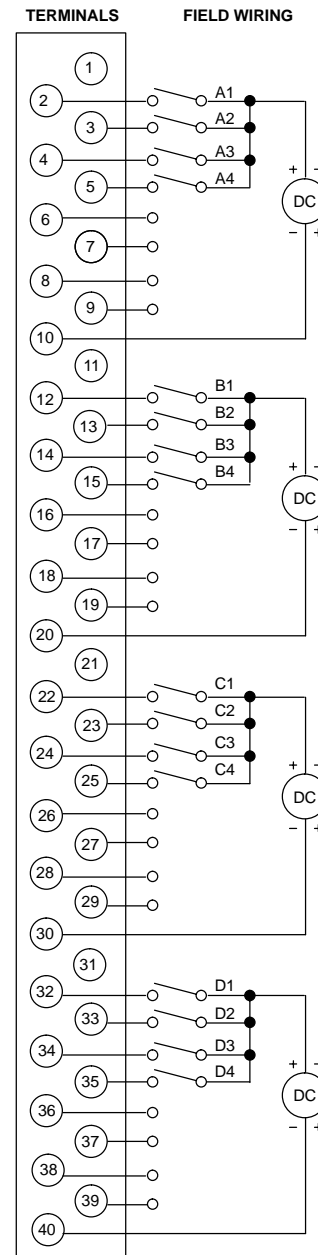

Figure 4. Field Wiring Connections

The detachable field wiring terminal board will accept wire sizes from #22 (0.36 mm²) through #14 (2.10 mm²). Two wires may be terminated on a given lug if both wires are the same size. There is room for a bundle of forty #14 (2.10 mm²) wires to be routed out through the terminal board cavity. The wire bundle can be secured to the terminal board by passing a cable tie through a cleat located at the lower corner of the terminal board.

GFK-0719D
August 1997

125 Volt DC Positive/Negative Logic, 16-Point Input Module

Recommended Field Wiring Procedures

The following procedures are recommended when connecting field wiring to the detachable terminal board on this input

module. Module features referenced in the following procedures which are common to all I/O modules for the IC697 PLC are illustrated in the following figure.

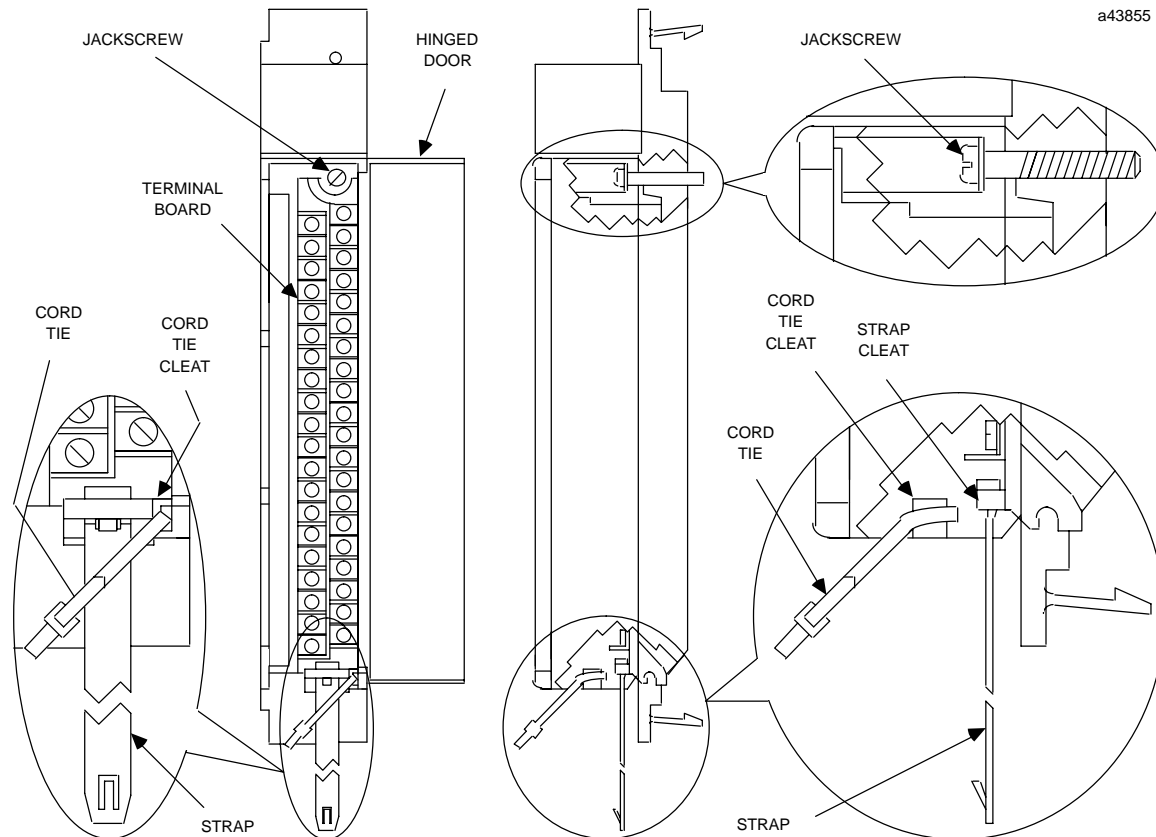

Figure 5. I/O Module Features

1. Turn off power before removing or installing terminal boards. Open the hinged door on the module to access a jackscrew which holds the terminal board securely in place. The Detachable field wiring terminal board can now be removed from the module by turning the jackscrew counter-clockwise until it is fully disengaged.
2. To remove the terminal board, grasp the top of the terminal board and swing it outward as shown in Figure 6.
3. The terminal board is designed to accept wire sizes from AWG #22 (0.36 mm²) through AWG #14 (2.10 mm²). It is important that when using AWG #14 (2.10 mm²) wire for wiring all points, that a maximum insulation diameter of .135 inch (3.43 mm) not be exceeded. To ensure proper connection, two wires may be terminated on any one terminal only if both wires are the same size.
4. The terminal board is designed to accept a maximum of (40) AWG #14 (2.10 mm²) wires. If AWG #14 (2.10 mm²) wires are to be used, then wire markers should be placed at least 8 inches (203 mm) from termination end to provide sufficient space for the hinged door to close.

Caution

Do not use the hinged door to remove the terminal board. The hinged door could be damaged if this is done.

125 Volt DC Positive/Negative Logic, 16-Point Input Module

GFK-0719D
August 1997

Figure 6. Removal of I/O Terminal Board

5. After completing connections to all modules in a rack, the wire bundle must be secured. To ensure that the wire bundle is secured properly, it is recommended that a cable tie be wrapped around the wire bundle and tightly secured through the cable tie cleat located at the lower right corner of the terminal board. For extremely large wire bundles, additional cable ties should be used.
6. A door label insert is included with each module to indicate circuit wiring information and provide space to record user circuit wiring identification. A slot is provided on the hinged door to allow for insertion of this label. If the label is difficult to insert, crease the scored edge before insertion. The outside label has a color coded stripe to allow quick identification of the module voltage type (blue: low voltage; red: high voltage).
7. After field wiring is completed, the terminal board should be securely fastened to the rack by inserting the terminal board strap (attached to each module) into the small rectangular slots in the bottom card guide grill on the rack. This strap not

only secures the terminal board to the rack, it also provides a way of identifying the wired terminal board with its correct mating rack slot location.

8. For adequate module ventilation, it is recommended that at least a 6 inch (152 mm) clearance be allowed above and below the rack grill. Wire bundles should not obstruct the rack grill work.

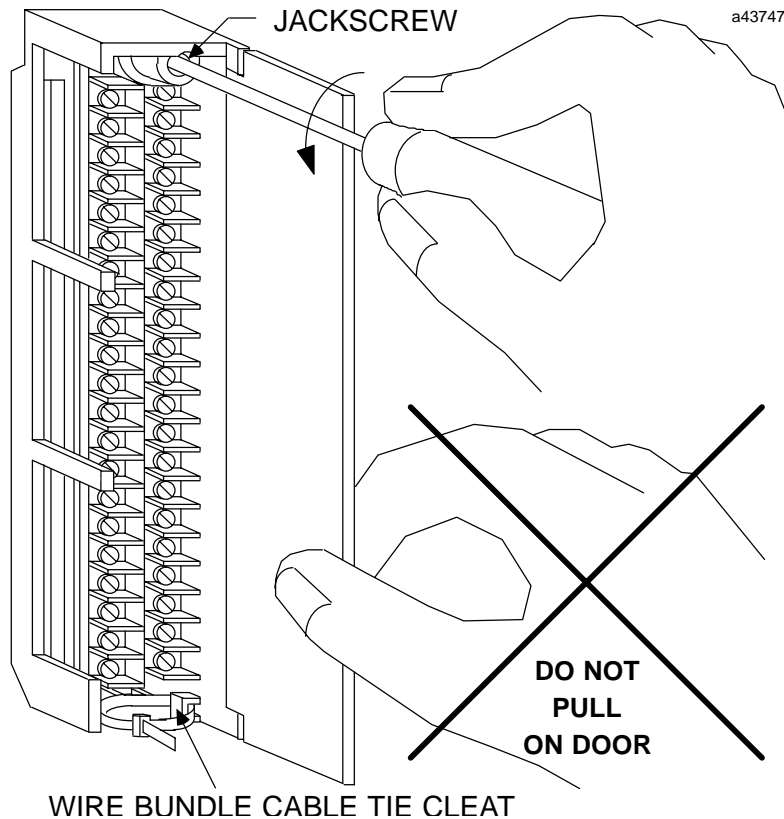
Removing an I/O Module

The instructions below should be followed when removing an I/O module from its slot in a rack.

- Grasp the board firmly at the top and bottom of the board cover with your thumbs on the front of the cover and your fingers on the plastic clips on the back of the cover.
- Squeeze the rack clips on the back of the cover with your fingers to disengage the clip from the rack rail and pull the board firmly to remove it from the backplane connector.
- Slide the board along the card guide and remove it from the rack.

GFK-0719D
August 1997

125 Volt DC Positive/Negative Logic, 16-Point Input Module

Table 1. Specifications for IC697MDL640 †

Rated Voltage:	125 volts DC
Inputs per Module ‡:	16 (four groups of four inputs each)
Isolation:	1500 volts RMS - any input to backplane 500 volts RMS between input groups
Input Voltage Range (V_s)	-35 to +145 volts DC
Input Current:	5mA (typical) at rated voltage
Input Impedance:	24.5K ohm, typical
Input Characteristics -	
On-state Voltage:	Positive: 90 volts to 145 volts Negative: -20 volts to V _s -90 volts
On-state Current:	3mA to 7mA
Off-state Voltage:	Positive: -35 volts to +35 volts Negative: V _s -35 volts to 56 volts
Off-state Current:	0 to 2mA (2mA minimum at 125V input)
Filter Delay Time:	1 ms or 10 ms configurable
Current Required from 5VDC backplane bus:	0.30 amps
VME	System designed to support the VME standard C.1

† Refer to GFK-0867B, or later for product standards and general specifications. For installations requiring compliance to more stringent requirements (for example, FCC or European Union Directives), refer to *Installation Requirements for Conformance to Standards*.

‡ Number of inputs on is dependent upon ambient temperature as shown in Figure 3.

Table 2. Ordering Information

Description	Catalog Number
Input Module: 125 Volt DC Positive/Negative Logic, 16 Points	IC697MDL640

Note: For Conformal Coat option, or Low Temperature Testing option please consult the factory for price and availability.

Discrete Input Modules

IC697MDL651

GFK-0377D
August 1997

TTL, Negative Logic, 32-Point Input Module

Features

- 32 TTL compatible Input points
- No user power required
- Each Input has pullup resistor
- Input filter selectable* - 1 ms or 10 ms
- One input configurable as interrupt*

* These features are available for all IC697 programmable controllers (PLCs). They may not be available when this module is used with other types of PLCs. See the applicable *Programmable Controller Installation Manual* for details.

Functions

The TTL Input Module for the IC697 programmable controller provides 32 TTL compatible input points which are configured as one group.

No user power is required and the use of open-collector drivers is simplified since each input has an internal pullup.

LED indicators which give the ON-OFF status of each point on the logic (PLC) side of the circuit are included at the top of the module.

The module is mechanically keyed to ensure correct replacement with a similar type in the field. I/O references are user configurable without the use of jumpers or DIP switches on the module.

Configuration is done using the configuration function of the MS-DOS® or Windows® programming software running on Windows® 95 or Windows NT® over Ethernet TCP/IP or through the SNP port. The Programming Software configuration function is installed on the programming device. The programming device can be an IBM® XT, AT, PS/2® or compatible Personal Computer.

® IBM and PS/2 are registered trademarks of International Business Machines Corporation.

® MS-DOS, Windows, Windows 95, and Windows NT are registered trademarks of Microsoft Corporation.

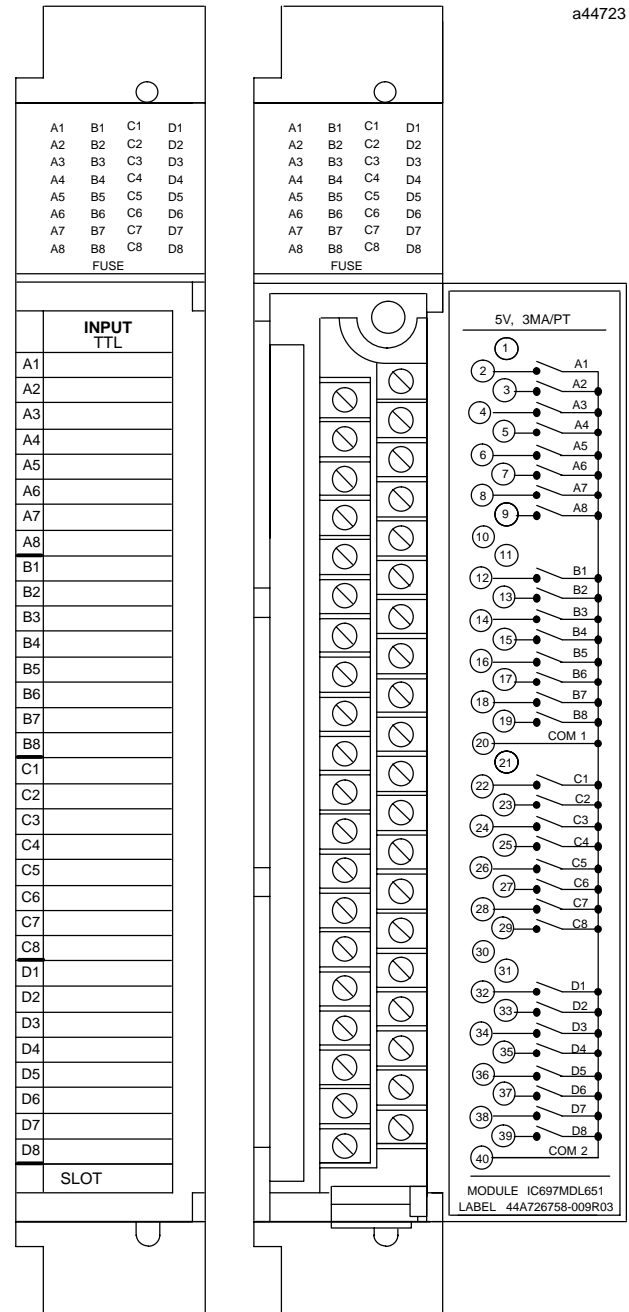

GFK-0377D
August 1997

TTL, Negative Logic, 32-Point Input Module

Operation - TTL Input Module

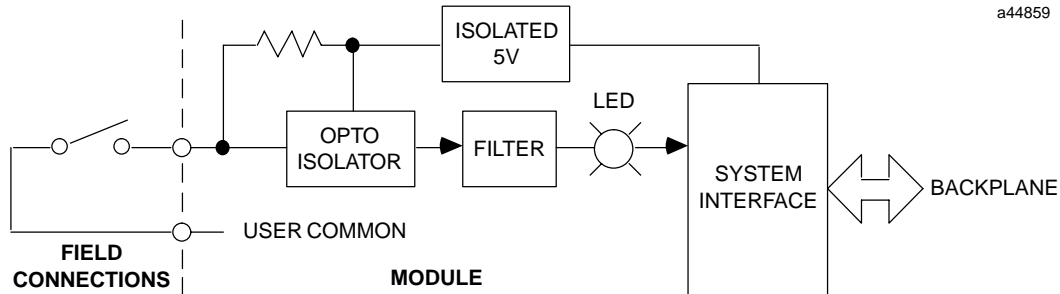

Figure 1. Block Diagram for IC697MDL651

Input Characteristics

This input module is designed to have negative logic characteristics - it sinks current from the input device to the user common. The input device is connected between the power bus and the module input as shown above.

This module is compatible with a wide variety of input devices, such as:

- Pushbuttons, limit switches, selector switches;
- Counters, BCD outputs, and other TTL compatible outputs.

In addition, inputs on this module may be directly driven by any IC697 PLC voltage compatible output module.

The module contains an isolated 5V supply and pull-up resistors for each input point. This configuration simplifies the use of open-collector drivers and eliminates the need for a user supplied power source.

Input current is typically 1.7mA in the ON state, and can accept up to 1.1mA leakage current in the OFF state without turning on.

Input Filter Selection

With the IC697 PLC and certain other CPU options, this module may be configured to have either a 1 ms or 10 ms input filter. Configuration is on a module, not per point basis; all points have the same filter time. See the applicable *Programmable Controller Installation Manual* and the *Programming Software User's Manual* for detailed information.

Interrupt

When used with an IC697 CPU, input point A1 may be configured to cause a CPU interrupt. Configuration allows the CPU to be interrupted on either the rising or falling edge of the signal transition. Interrupt response is not affected by input filter time selection. Refer to the *Programmable Controller Installation Manual* for detailed information.

Module Mechanical Keying

This module includes a mechanical key that prevents inadvertent substitution of one module type for another in a given slot. The key fits a uniquely shaped area on the board below the connector. Each module has a key packaged with it.

When the module is first installed, the key latches onto the backplane center rail. When the module is extracted, the key remains in the center rail, configuring the slot to accept only identical module types.

If it is necessary to change the module location in the rack after the key has been latched onto the center rail of the rack, the key can be removed by pushing it upward to unhook the latch while pulling it off the rail. It may then be reinserted onto the module and the module inserted into the rack in the desired location.

Note that in an IC697 PLC rack only the power supply can be placed in the leftmost rack position, and slot 1 (adjacent to the power supply) must always contain a CPU (in rack 0 - the CPU rack), or a Bus Receiver Module (in an expansion rack).

TTL, Negative Logic, 32-Point Input Module

GFK-0377D
August 1997

Field Wiring

The module is wired as shown in Figure 2. Since the 32 points share a common, only one connection is required between user common and the module common (pin 20 or 40). However, two user connections are provided for wiring convenience.

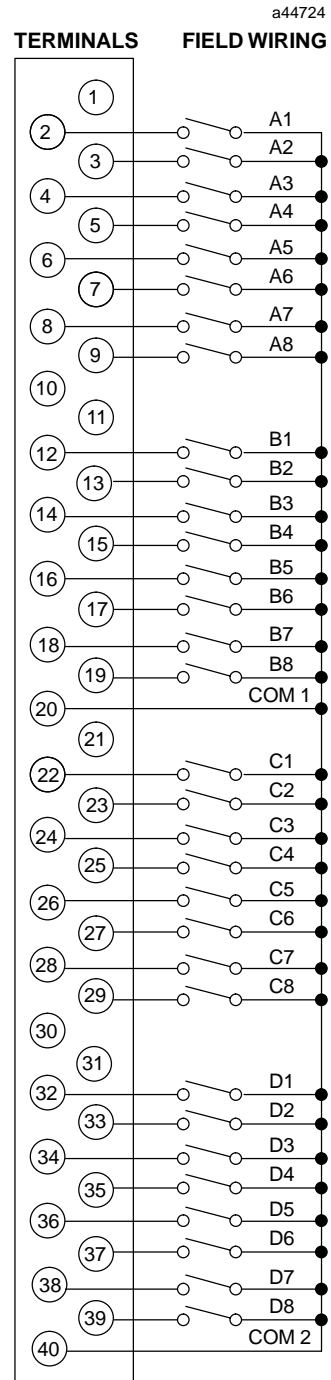

Figure 2. Field Wiring Connections for IC697MDL651

GFK-0377D
August 1997

TTL, Negative Logic, 32-Point Input Module

Recommended Field Wiring Procedures

The following procedures are recommended when connecting field wiring to the detachable terminal board on this input

module. Module features referenced in the following procedures which are common to all IC697 I/O modules are illustrated in the following figure.

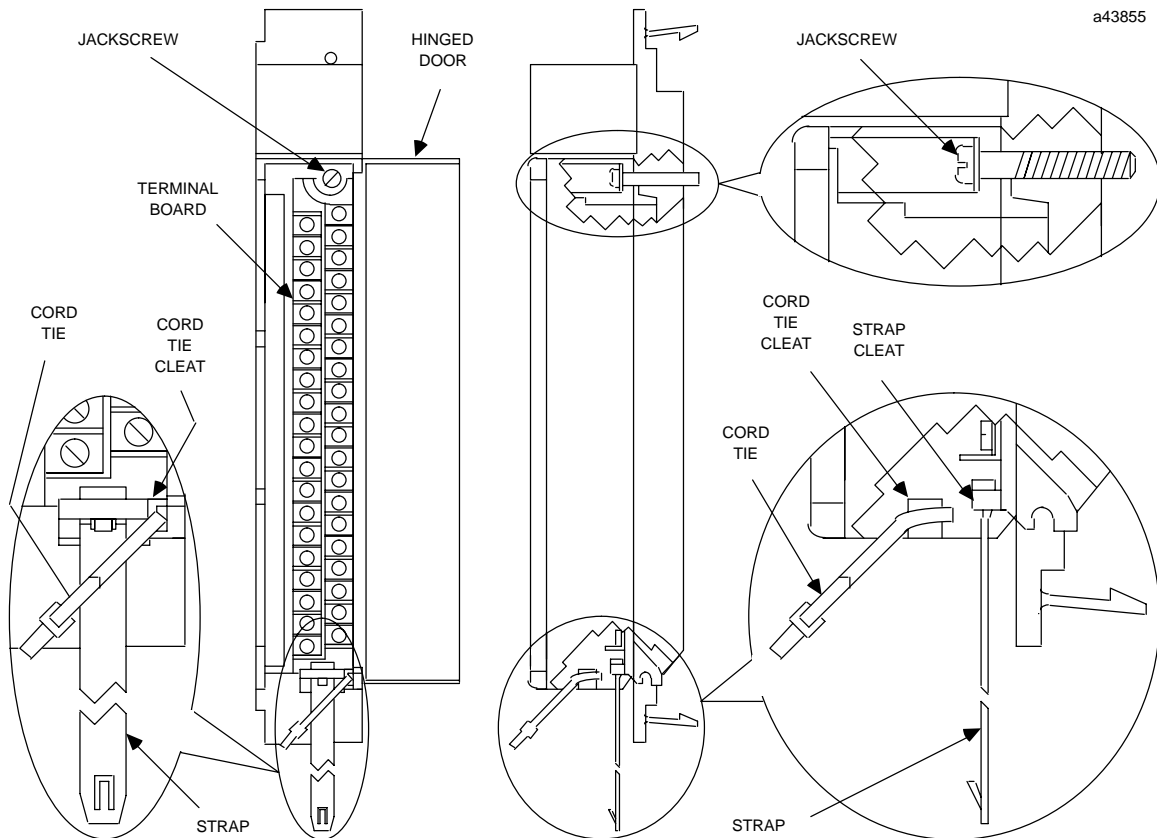

Figure 3. I/O Module Features

1. Turn off power before removing or installing terminal boards. Open the hinged door on the module to access a jackscrew which holds the terminal board securely in place. The detachable field wiring terminal board can now be removed from the module by turning the jackscrew counter-clockwise until it is fully disengaged.
2. To remove the terminal board, grasp the top of the terminal board and swing it outward as shown in Figure 3.
3. The terminal board is designed to accept wire sizes from AWG #22 (0.36 mm²) through AWG #14 (2.10 mm²). It is important that when using AWG #14 (2.10 mm²) wire for wiring all points, that a maximum insulation diameter of .135 inch (3.43mm) not be exceeded. To ensure proper connection, two wires may be terminated on any one terminal only if both wires are the same size.
4. The terminal board is designed to accept a maximum of (40) AWG #14 (2.10 mm²) wires. If AWG #14 (2.10 mm²) wires are to be used, then wire markers should be placed at least 8 inches (203 mm) from termination end to provide sufficient space for the hinged door to close.

Caution

Do not use the hinged door to remove the terminal board. The hinged door could be damaged if this is done.

TTL, Negative Logic, 32-Point Input Module

GFK-0377D
August 1997

Figure 4. Removal of I/O Terminal Board

5. After completing connections to all modules in a rack, the wire bundle must be secured. To ensure that the wire bundle is secured properly, it is recommended that a cable tie be wrapped around the wire bundle and tightly secured through the cable tie cleat located at the lower right corner of the terminal board. For extremely large wire bundles, additional cable ties should be used.
6. A door label insert is included with each module to indicate circuit wiring information and provide space to record user circuit wiring identification. A slot is provided on the hinged door to allow for insertion of this label. If the label is difficult to insert, crease the scored edge before insertion. The outside label has a color coded stripe to allow quick identification of the module voltage type (blue: low voltage; red: high voltage).
7. After field wiring is completed, the terminal board should be securely fastened to the rack by inserting the terminal board strap (attached to each module) into the small rectangular slots in the bottom card guide grill on the rack. This strap not

only secures the terminal board to the rack, it also provides a way of identifying the wired terminal board with its correct mating rack slot location.

8. For adequate module ventilation, it is recommended that at least a 6 inch (152mm) clearance be allowed above and below the rack grill. Wire bundles should not obstruct the rack grill work.

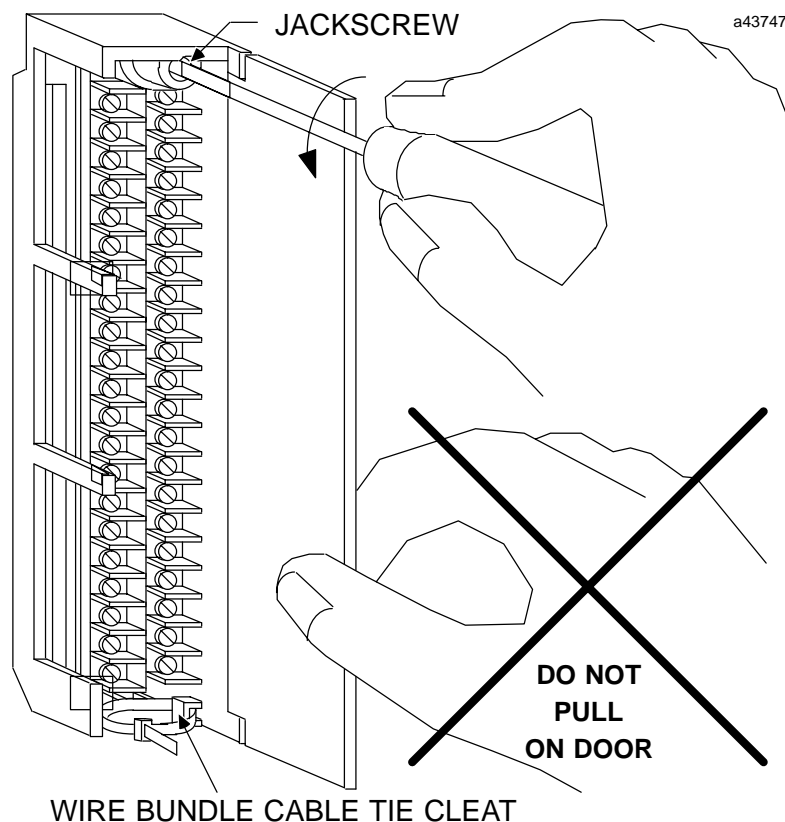
Removing an I/O Module

The instructions below should be followed when removing an I/O module from its slot in a rack.

- Grasp the board firmly at the top and bottom of the board cover with your thumbs on the front of the cover and your fingers on the plastic clips on the back of the cover.
- Squeeze the rack clips on the back of the cover with your fingers to disengage the clip from the rack rail and pull the board firmly to remove it from the backplane connector.
- Slide the board along the card guide and remove it from the rack.

GFK-0377D
August 1997

TTL, Negative Logic, 32-Point Input Module

Table 1. Specifications for IC697MDL651 †

Rated Voltage:	5 volts DC
Inputs per Module:	32 98.4' (30m) maximum cable length
Isolation:	1500 volts - any input to backplane
Input Voltage Range (V_s):	-3 to +7 volts DC
Input Characteristics	
Impedance:	5.9K ohms, ±5%
On-state Voltage:	-3 volts to 0.5 volts
Off-state Voltage:	2 volts to 7 volts
On-state Current:	1.7mA (typical) at rated voltage
Off-state Current:	1.1mA (maximum)
Filter Delay Time:	1 ms or 10 ms configurable
Current Required from 5V Bus:	.53 amp
VME	System designed to support the VME standard C.1

† Refer to GFK-0867B, or later for product standards and general specifications. For installations requiring compliance to more stringent requirements (for example, FCC or European Union Directives), refer to *Installation Requirements for Conformance to Standards*.

Table 2. Ordering Information

Description	Catalog Number
Input Module, Negative Logic TTL, 32 Points	IC697MDL651

Note: For Conformal Coat option, or Low Temperature Testing option please consult the factory for price and availability.

Discrete Input Modules

IC697MDL671

GFK-0880C
August 1997

Interrupt Module, 14 Point, 24 Volt DC Positive/Negative Logic

Features

- 16 points total - 4 isolated groups of 4 points each
- 14 interrupt points; 2 configuration points
- Positive/Negative logic compatibility
- Proximity switch compatible
- Input filter selectable - 1 ms or 10 ms
- All 14 interrupts can run at maximum I/O interrupt rate (See Table 1 for module specifications).
- First input configured as interrupt

Functions

The **24 Volt DC Positive/Negative Logic Interrupt Input Module** provides 16 points total in four isolated groups of four points each. The first 14 points (A1 through D2) are interrupt inputs and the last 2, D3 and D4 are configuration inputs. The input current-voltage characteristics meet IEC standard (type 1) specifications.

LED indicators which give the ON-OFF status of each point are located at the top of the module.

The module is mechanically keyed to ensure correct replacement with a similar type in the field. I/O references are user configurable without the use of jumpers or DIP switches on the module.

Configuration is done using the configuration function of the MS-DOS® or Windows® programming software running on Windows® 95 or Windows NT® over Ethernet TCP/IP or through the SNP port. The Programming Software configuration function is installed on the programming device. The programming device can be an IBM® XT, AT, PS/2® or compatible Personal Computer.

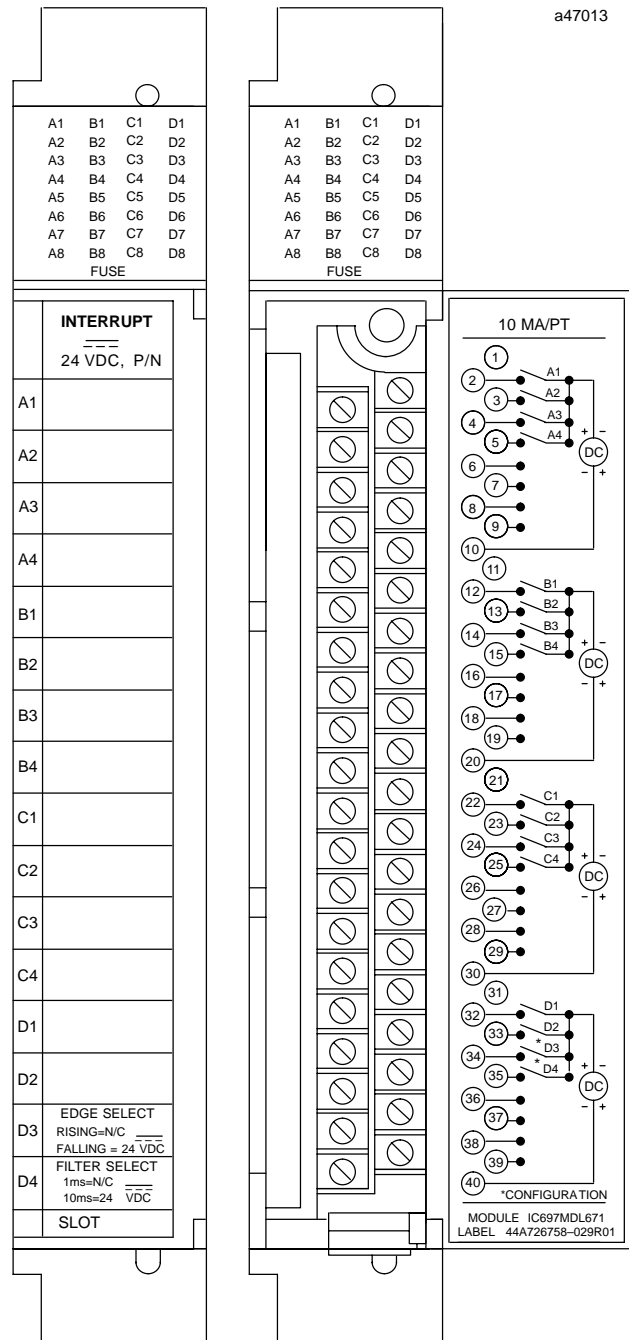

© IBM and PS/2 are registered trademarks of International Business Machines Corporation.

© MS-DOS, Windows, Windows 95, and Windows NT are registered trademarks of Microsoft Corporation.

GFK-0880C
August 1997

Interrupt Module, 14 Point, 24 Volt DC Positive/Negative Logic

Operation - 24 Volt DC Positive/Negative Logic Interrupt Module

Operation of the Interrupt module is described following the illustration of a block diagram of the module.

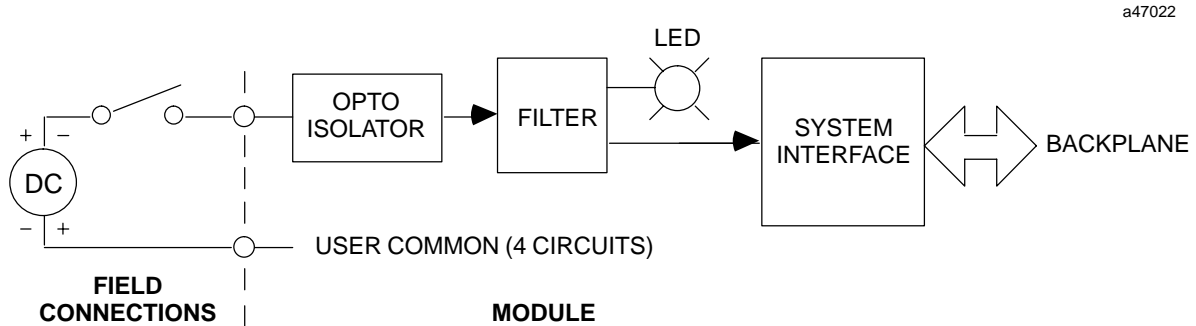

Figure 1. Block Diagram for IC697MDL671

This interrupt module will generate an interrupt to the PLC, allowing the execution of an interrupt block, when any or all of its 14 interrupt inputs satisfy its configured edge and filter selection. All interrupts are reported as one word at the module's selected reference address. The PLC reads the interrupt word and acknowledges the interrupt. The module is then ready to generate the next PLC interrupt.

Note

If you are using CPU software earlier than Release 6.00 this module requires a ladder diagram to perform the above functions. The ladder diagram is provided as Attachment A at the end of this data sheet.

Interrupts are edge triggered and require a minimum pulse width (as configured) for the trigger to occur. Interrupts on a single input may not occur at a frequency greater than 500 Hz with a model CPM915 CPU (frequency depends on model of CPU, see Table 1 for more information). Within an interrupt module, interrupts will be reported as they are received which means that all interrupts have equal priority. Multiple interrupts may be reported simultaneously.

Software Configuration Requirements

Release 4.02 or later of IC641 programming software is required for configuration of the module. When the module is selected via the Configuration function, the proper configuration is automatically set. The only

available configuration option is to select the %I reference address.

Module Configuration

The configuration inputs D3 and D4 configure all 14 interrupt inputs at power-up. The module will default to *rising edge trigger* and *1 ms interrupt filter* with no configuration input connection. Configuration inputs D3 and D4 are read only at system power-up. Activating input D3 will reconfigure the module (after a power cycle) for falling edge detection. Activating input D4 will reconfigure the module (after a power cycle) for a 10 ms interrupt filter. The module configuration cannot change after power-up.

I/O Triggered Interrupt Block

Each Interrupt module can call one LD (Ladder Diagram) program block triggered by the first input address configured for the module (similar to other IC697 Input modules). This means that an Interrupt module configured at %I0001 must be programmed to execute an LD program block triggered by %I0001. To do this, the program block must first be included in the program block declarations and then entered in the interrupt declaration editor.

Event Triggered Programs

Each interrupt module can cause an event-triggered program to be scheduled for execution. The trigger must be the first %I reference configured for this module.

Interrupt Module, 14 Point, 24 Volt DC Positive/Negative Logic

GFK-0880C
August 1997

Interrupt Word Default

At power-up, configuration dependent default data is present at the %I reference for the Interrupt module regardless of the level of each interrupt input. The default data for rising edge selection is all zeros; the default data for falling edge selection is all ones. The level of the configuration bits detected at power-up will also be present in the default word.

Interrupt Reporting

An interrupt received on any of the 14 interrupt inputs will cause an interrupt to be sent to the CPU. The CPU will read the interrupt module and capture

the interrupt conditions at the time the CPU interrupt was generated. This data will be written to the %I reference that has been configured for the module. Current interrupt data is valid within the interrupt block only. Each interrupt input corresponds to a bit in the interrupt word. The interrupt word also contains the module configuration read at power-up.

Modules configured for positive edge trigger will report a 1 (one) for active interrupts while negative edge interrupts will report a 0 (zero) for active interrupts. The interrupt handling logic must reference the %I data to determine which subset of the interrupt points are active (see *Interrupt Handling Logic* below).

Interrupt Word

Two examples of interrupt reports are shown below.

RISING EDGE

D4	D3	D2	D1	C4	C3	C2	C1	B4	B3	B2	B1	A4	A3	A2	A1
1	0	0	0	0	0	0	0	0	0	0	0	0	0	1	0

D4 = 10 ms Filter Select
D3 = Rising Edge Select
A2 = Positive Interrupt

FALLING EDGE

D4	D3	D2	D1	C4	C3	C2	C1	B4	B3	B2	B1	A4	A3	A2	A1
0	1	1	1	1	1	1	1	0	1	1	1	1	1	1	1

D4 = 1 ms Filter Select
D3 = Falling Edge Select
B4 = Negative Interrupt

Interrupt Handling Logic

Any user application logic you have developed for an interrupt module should be contained in the interrupt handling logic associated with that module. Logic outside of the interrupt handling logic will have no meaningful data to act upon. *The interrupt bits and associated transitions are undefined outside of the interrupt handling logic.*

If the interrupt handling logic is an interrupt block within the RLD program, then the global %I contacts and/or %I transition contacts can be referenced to determine which interrupt points are active.

If the interrupt handling logic is an event-triggered standalone C program, then the %I word should be included in the program's input specification list. This data can then be referenced using the input specification macros to determine which interrupt points are active. Refer to the *C Programmer's Toolkit Reference Manual* for more information.

Note

Referencing the global %I data directly from within a standalone C program is not recommended since the global data may not reflect the state of the %I bits at the time at which the interrupt occurred.

If the interrupt handling logic is an event-triggered RLD program, then the global %I data can be referenced to determine which interrupt points are active. However, this is not recommended since the global %I data may not reflect the state of the %I bits at the time that the interrupt occurred.

Refer to the *IC697 Programmable Controller Reference Manual* for more information on interrupt handling logic.

GFK-0880C
August 1997

Interrupt Module, 14 Point, 24 Volt DC Positive/Negative Logic

Interrupt Buffer

Interrupts received while the CPU is processing a previous interrupt will be stored in a buffer. When the CPU acknowledges the previous interrupt, the module will immediately generate a new CPU interrupt to report all of the buffered interrupts. For buffered interrupts, data is not available about the number of interrupts received on a single input. Information about the order in which interrupts from different inputs occurred is also not available for buffered interrupts.

Important Module Information

- Interrupt modules cannot be used in a Remote I/O Scanner rack since a remote drop *cannot* have any I/O module interrupts.
- If a DOIO instruction is used with an I/O interrupt, transition contacts associated with scanned inputs may not operate as expected.
- When using the Mask/Unmask I/O Interrupt Service Request #17 (SVCREQ #17), the mask applies to all interrupts on the module. When entering the address of the interrupt to mask, use the first %I reference of the module.

Caution

Caution should be exercised since an I/O interrupt can interrupt the execution of a function block in the main block or any program block. This means that unexpected results may occur if the interrupt block and a program block access the same data.

Input Characteristics

This input module is designed to have both positive and negative logic characteristics in that it sinks or sources current from the input device to the user common. The input device is connected between the power bus and the module input as shown in Figure 1.

This module is compatible with a wide variety of input devices, such as:

- Pushbuttons, limit switches, selector switches;

- Electronic proximity switches, both 2-wire and 3-wire.

In addition, inputs on this module may be directly driven by any IC697 PLC voltage compatible output module.

The input circuitry provides sufficient current to ensure reliable operation of the switching device. Input current is typically 10mA in the ON state, and can accept up to 2 mA leakage current in the OFF state without turning on.

3-wire proximity switches are easily applied, since they provide low voltage drop in the ON state and low leakage current in the OFF State.

2-wire proximity switches derive their power from the signal connections; thus both the ON state voltage and the OFF state leakage current are higher than for 3-wire devices. This module is designed to be compatible with many such 2-wire devices; however each device type must be carefully evaluated for compatibility in both the ON and OFF states.

To determine compatibility with a specific proximity switch, find the ON state characteristics of the switch in the diagram shown in Figure 2. If that point falls to the left of the input load line, the ON state characteristics are compatible. As an example, the ON state requirements of a compatible proximity switch of 3mA at 5 volts drop are shown in Figure 2.

OFF state compatibility is assured if the proximity switch leakage is less than 2mA with a module input voltage of 5 volts or less.

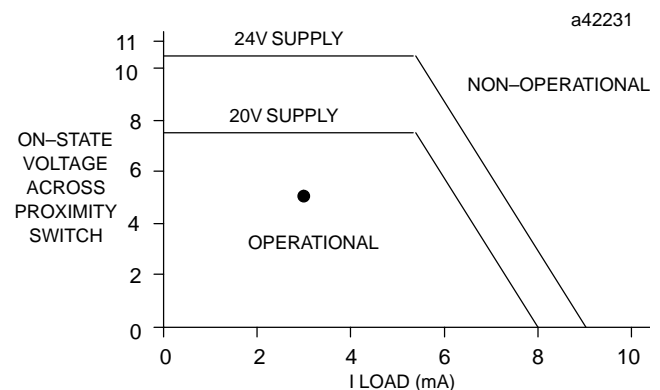

Figure 2. Proximity Switch Compatibility

Interrupt Module, 14 Point, 24 Volt DC Positive/Negative Logic

GFK-0880C
August 1997

Module Mechanical Keying

This module includes a mechanical key that prevents inadvertent substitution of one module type for another in a given slot. The key fits a uniquely shaped area on the board below the connector. Each module has a key packaged with it.

When the module is first installed, the key latches onto the backplane center rail. When the module is extracted, the key remains in the center rail, configuring the slot to accept only identical module types.

If it is necessary to change the module location in the rack after the key has been latched onto the center rail of the rack, the key can be removed by pushing it upward to unhook the latch while pulling it off the rail. It may then be reinserted onto the module and the module inserted into the rack in the desired location.

Note that in an IC697 PLC rack only the power supply can be placed in the leftmost rack position, and slot 1 (adjacent to the power supply) must always contain a CPU (in rack 0 - the CPU rack), or a Bus Receiver Module (in an expansion rack).

Field Wiring

The module is wired as shown in Figure 3. Since each group of four inputs is isolated from the others, a wire from the power source to the power input terminal (10, 20, 30, or 40) for each group is required (power input terminals for each group are not connected inside the module). Each group can be powered to operate as either positive logic or negative logic.

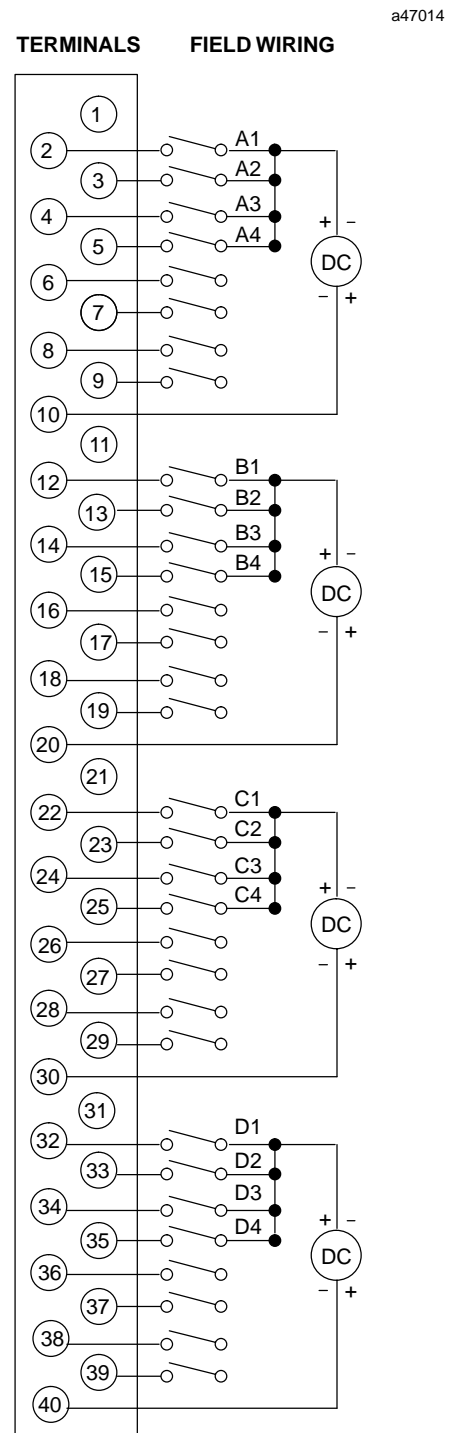

Figure 3. Field Wiring Connections for IC697MDL671

GFK-0880C
August 1997

Interrupt Module, 14 Point, 24 Volt DC Positive/Negative Logic

Recommended Field Wiring Procedures

The following procedures are recommended when connecting field wiring to the detachable terminal

board on this input module. Module features referenced in the following procedures which are common to all IC697 I/O modules are illustrated in the following figure.

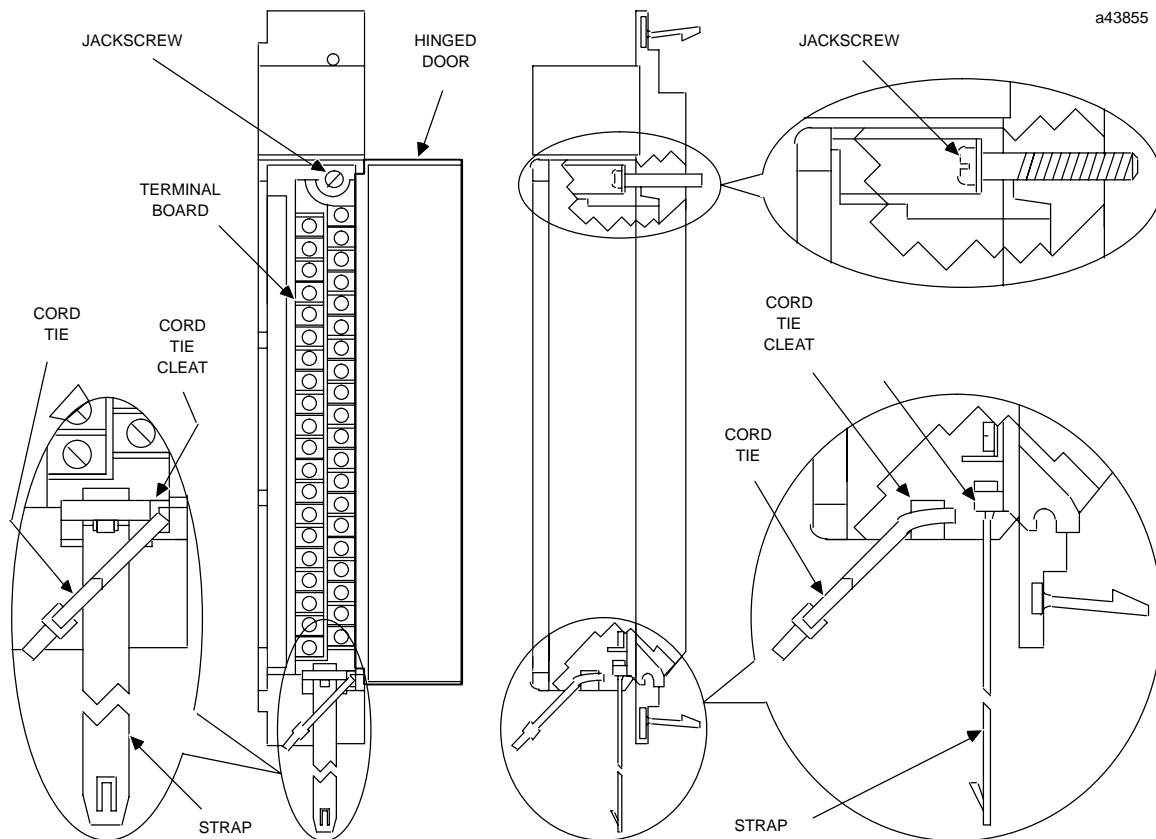

Figure 4. I/O Module Features

1. Turn off power before removing or installing terminal boards. Open the hinged door on the module to access a jackscrew which holds the terminal board securely in place. The detachable field wiring terminal board can now be removed from the module by turning the jackscrew counter-clockwise until it is fully disengaged.
2. To remove the terminal board, grasp the top of the terminal board and swing it outward.
3. The terminal board is designed to accept wire sizes from AWG #22 (0.36 mm^2) through AWG #14 (2.10 mm^2). It is important that when using AWG #14 (2.10 mm^2) wire for wiring all points, that a maximum insulation diameter of .135 inch (3.43 mm) not be exceeded. To ensure proper connection, two wires may be terminated on any one terminal only if both wires are the same size.
4. The terminal board is designed to accept a maximum of (40) AWG #14 (2.10 mm^2) wires. If AWG #14 (2.10 mm^2) wires are to be used, then wire markers should be placed at least 8 inches (203 mm) from termination end to provide sufficient space for the hinged door to close.

Caution

Do not use the hinged door to remove the terminal board. The hinged door could be damaged if this is done.

Interrupt Module, 14 Point, 24 Volt DC Positive/Negative Logic

GFK-0880C
August 1997

Figure 5. Removal of I/O Terminal Board

5. After completing connections to all modules in a rack, the wire bundle must be secured. To ensure that the wire bundle is secured properly, it is recommended that a cable tie be wrapped around the wire bundle and tightly secured through the cable tie cleat located at the lower right corner of the terminal board. For extremely large wire bundles, additional cable ties should be used.
6. A door label insert is included with each module to indicate circuit wiring information and provide space to record user circuit wiring identification. A slot is provided on the hinged door to allow for insertion of this label. If the label is difficult to insert, crease the scored edge before insertion. The outside label has a color coded stripe to allow quick identification of the module voltage type (blue: low voltage; red: high voltage).
7. After field wiring is completed, the terminal board should be securely fastened to the rack by inserting the terminal board strap (attached to each module) into the small rectangular slots in the bottom card guide grill on the rack. This strap not only secures the terminal board to the rack, it also provides a

way of identifying the wired terminal board with its correct mating rack slot location.

8. For adequate module ventilation, it is recommended that at least a 6 inch (152 mm) clearance be allowed above and below the rack grill. Wire bundles should not obstruct the rack grill work.

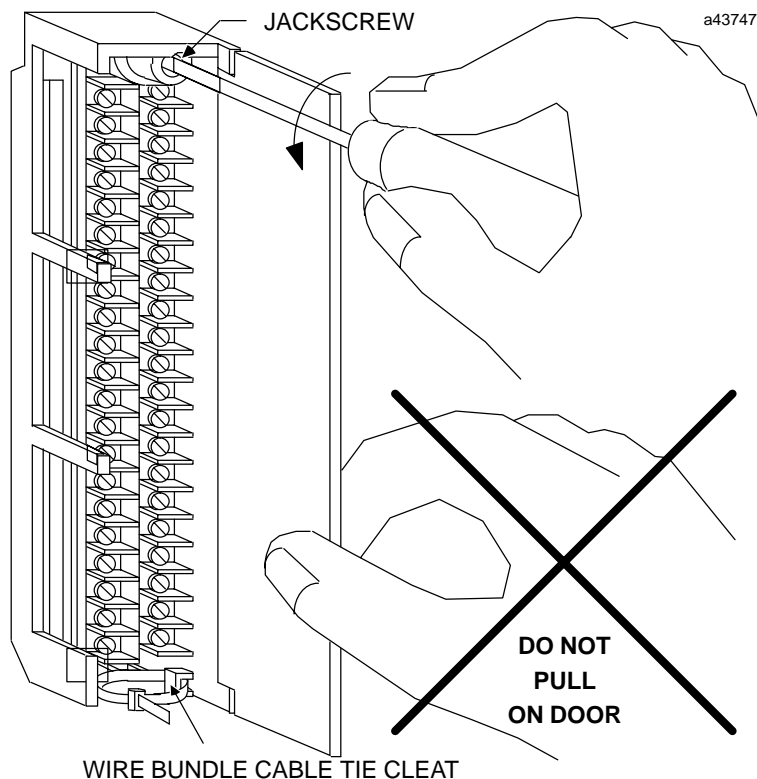
Removing an I/O Module

The instructions below should be followed when removing an I/O module from its slot in a rack.

- Grasp the board firmly at the top and bottom of the board cover with your thumbs on the front of the cover and your fingers on the plastic clips on the back of the cover.
- Squeeze the rack clips on the back of the cover with your fingers to disengage the clip from the rack rail and pull the board firmly to remove it from the backplane connector.
- Slide the board along the card guide and remove it from the rack.

GFK-0880C
August 1997

Interrupt Module, 14 Point, 24 Volt DC Positive/Negative Logic

Attachment A - Using CPU Software Earlier Than Release 6.00

Unsupported CPU Interface to Module

Full CPU support for this module was not available with CPU software prior to Release 6.00. The Interrupt module requires IC641 programming software ladder logic when using CPU software earlier than Release 6.00. This logic is available on the PLC Bulletin Board with a file name of gfk671.zip. For information on how to use the Bulletin board, contact your local authorized PLC distributor or sales office. Also, the following rules must be followed when using the module:

- The Interrupt module will only function when installed in Rack 0.
- Calls to other program blocks and external blocks are not allowed inside an interrupt block.
- TheMask/UnmaskI/OInterrupt Service Request #17 (SVCREQ #17) cannot be used.
- Event triggered programs are not supported.

IC641 Programming Software Support Ladder Logic

The following logic is required for each Interrupt module used without the availability of full PLC CPU support. This logic contains the following required operations:

- First scan interrupt acknowledge to clear interrupts occurring during the PLC CPU STOP mode.
- Reads the interrupt word at slot address +92H using a VME READ instruction.
- Interrupt acknowledge: two VME WRITE instructions using inputs 1DH (Hexadecimal) and 15H (Hexadecimal) at slot address +81H (Hexadecimal).
- Toggle module's %I reference for transition contacts.

Note

Do not use this ladder logic with CPU software Release 6.00, or later. It is only intended to be used with CPU software prior to Release 6.00

```
[ PROGRAM BLOCK DECLARATIONS ]
      +-----+
      | INT3 | LANG: LD      (* Interrupt bd slot 3 *)
      +-----+

[ INTERRUPTS ]

(*****
(* Interrupt Block I/O triggered by first %I reference address for the *)
(* module. *)
(*****

      +-----+
+----->[%I0001]---->|CALL INT3 |
      +-----+

[ START OF PROGRAM LOGIC - MAIN BLOCK ]
| (*****
| (* First scan call resets board and clears interrupts which may have *)
| (* occurred during PLC stop mode. Should be the first rung in main. *)
| (*****
|
| << RUNG 5 >>
|
| FST_SCN +-----+
+--] [---+CALL INT3 +
|      +-----+
|
[ END OF PROGRAM LOGIC ]
```

Interrupt Module, 14 Point, 24 Volt DC Positive/Negative Logic

GFK-0880C
August 1997

```
+ [ START OF LD BLOCK INT3 ]
|
| [ VARIABLE DECLARATIONS ]
```

VARIABLE DECLARATION TABLE

REFERENCE	NICKNAME	REFERENCE DESCRIPTION
%I00001	ITABLE3	Interrupt Table
%L00001	SLOTTAB	Slot Address Table
%L00010	SLOT#	Slot number
%L00011	INTADD	Interrupt word address.
%L00012	HINT	High Interrupt Address. (0)
%L00013	MODEADD	Mode register Address.
%L00014	HMODE	High Mode Address (0).
%L00015	INTWD3	Interrupt Word
%L00016	TIME1	Time from start of sweep.
%L00017	DELAYT	Time1 + delay time.
%L00018	TIME2	Time after delay elapse.

```
( ***** )
(* Data Init below is look-up table for Rack 0 slot addressing. *)
(* %L12 and %L14 clear upper address for INTADD and MODEADD. *)
( ***** )
```

DATA _ I N I T F U N C T I O N					
New Value >		Element: 00001		Length: 00009	
(Ordered left to right)					
1	+00000	+04096	+06144	+08192	+10240
6	+12288	+14336	+16384	+18432	

```
<< RUNG 4 >>
```

```
| FST_EXE +-----+ +-----+ +-----+
+--] [---+DATA_+-----+MOVE_+-----+MOVE_+---
| | INIT_ | | INT | | INT |
| | INT | | | | |
| | Q+-SLOTTAB CONST -+IN Q+- HINT CONST -+IN Q+- HMODE
| | LEN | +00000 | LEN | +00000 | LEN |
| |00009| |00001| |00001|
| +-----+ +-----+ +-----+
```

```
( ***** )
(* User to provide slot# for Interrupt board at constant 3 example below. *)
(* INTADD = Interrupt word address; slot + 92h *)
(* MODEADD = Reset address; slot + 81h. *)
( ***** )
```

GFK-0880C
August 1997

Interrupt Module, 14 Point, 24 Volt DC Positive/Negative Logic

```

| << RUNG 6 >>
|
| FST_EXE +-----+
|---] [---+MOVE_+-----+ ADD_+-----+ ADD_+---
|          | INT |          | INT |          | INT |
|          |   |          |   |          |   |
| CONST --+IN Q+- SLOT#  CONST --+I1 Q+-INTADD  CONST --+I1 Q+-MODEADD
| +00003 | LEN |          +00146 |   |          +00129 |   |
|         |00001|          ( 92h) |   |          ( 81h) |   |
|         +-----+          @SLOT# --+I2 |          @SLOT# --+I2 |
|                                     +-----+          +-----+
|
£| << RUNG 7 >>
|
| FST_EXE
|---]/[----->> SKPFST
|
| (*****
| (* First scan logic clears interrupts which may have occurred while *)
| (* PLC-CPU was in stop mode. *)
| (*****
|
| << RUNG 9 >>
|
|          +-----+          +-----+
|-----+ VME_+-----+ VME_+---
|          | WRT_ |          | WRT_ |
|          | BYTE |          | BYTE |
|          CONST --+IN |          CONST --+IN |
|          001C | LEN |          0014 | LEN |
|          |00001|          |00001|
|          CONST --+AM |          CONST --+AM |
|          0029 |          0029 |
|          |          |
| MODEADD--+ADR |          MODEADD--+ADR |
|          +-----+          +-----+
|
| << RUNG 10 >>
|
|          +-----+          +-----+
|-----+ SVC_+-----+ ADD_+---
|          | REQ |          | UINT |
|          |   |          |   |
| CONST --+FNC | TIME1 --+I1 Q+-DELAYT
| 00009 |   |          |   |
|          |   |          |   |
| TIME1 --+PARM | CONST --+I2 |
|          +-----+ 00002 +-----+
|
| << RUNG 11 >>
|
| DELAY :

```

Interrupt Module, 14 Point, 24 Volt DC Positive/Negative Logic

GFK-0880C
August 1997

```

| << RUNG 12 >>
|
|           +-----+           +-----+
+-----+  SVC_+-----+  LT_ +-
|           | REQ |           | UINT|
|           |     |           |     |
| CONST --+FNC | TIME2 --+I1 | Q+----->> DELAY
| 00009 |     |           |     |
|           |     |           |     |
| TIME2 --+PARM | DELAYT --+I2 |
|           +-----+           +-----+
|
| << RUNG 13 >>
|
|           +-----+           +-----+
+-----+  VME_+-----+  VME_+-
|           | WRT_ |           | WRT_ | |
|           | BYTE|           | BYTE|
|           |     |           |     |
| CONST --+IN |           | CONST --+IN |
| 001C | LEN |           | 0015 | LEN |
| |00001|           | |00001|
| CONST --+AM |           | CONST --+AM |
| 0029 |     |           | 0029 |     |
|           |     |           |     |
| MODEADD--+ADR |           | MODEADD--+ADR |
|           +-----+           +-----+
|
| << RUNG 14 >>
|
+----->> EXIT
|
| << RUNG 15 >>
|
| SKPFST :
|
| (*****
| (* Read interrupt word at slot address + 92h. *)
| (* Length must be two bytes. *)
| (*****
|
| << RUNG 17 >>
|
|           +-----+
+-----+  VME_+-
|           | RD_ |
|           | BYTE|
|           |     |
| CONST --+AM |
| 0029 | LEN |
| |00002|
| INTADD --+ADR Q+--INTWD3
|           +-----+
|
| (*****
| (* Interrupt board reset (HSI toggle for interrupt acknowledge = slot *)
| (* address + 81h). *)
| (*****

```

GFK-0880C
August 1997

Interrupt Module, 14 Point, 24 Volt DC Positive/Negative Logic

```

| << RUNG 19 >>
|
|           +-----+           +-----+
+-----+ VME_+-----+ VME_+-
|           | WRT_ |           | WRT_ | |
|           | BYTE |           | BYTE |
|   CONST  --+IN |           |   CONST  --+IN |
|   001D  | LEN |           |   0015  | LEN |
|           |00001|           |           |00001|
|   CONST  --+AM |           |   CONST  --+AM |
|   0029  |   |           |   0029  |   |
|   MODEADD--+ADR |           |   MODEADD--+ADR |
|           +-----+           +-----+
|
| (*****
| (* Tests for falling edge configuration from config input D3.           *)
| (* Bit test Interrupt word (INTWD3) bit 15.                             *)
| (*****
|
| << RUNG 21 >>
|
|           +-----+
+-----+ BIT_+-
|           | TEST_ |
|           | WORD |
| INTWD3  --+IN  Q+----->> FALLEDD
|           | LEN |
|           |00001|
|   CONST  --+BIT |
|   00015 +-----+
|
| (*****
| (* Toggles transition table for positive transition contacts/coils      *)
| (* which function within the interrupt block only.                       *)
| (*****
|
| << RUNG 23 >>
|
|           +-----+           +-----+
+-----+ AND_+-----+ MOVE_+-
|           | WORD |           | WORD |
|           |   |           |   |
| INTWD3  --+I1  Q+--ITABLE3 INTWD3  --+IN  Q+--ITABLE3
|           | LEN |           | LEN |
|           |00001|           |00001|
|   CONST  --+I2 |           +-----+
|   C000 +-----+
|
| << RUNG 24 >>
|
+----->> USER
|

```

Interrupt Module, 14 Point, 24 Volt DC Positive/Negative Logic

GFK-0880C
August 1997

```

| << RUNG 25 >>
|
| FAILEDG :
|
| (*****
| (* Toggles transition table for negative transition contacts/coils *)
| (* which function within the interrupt block only. *)
| (*****
|
| << RUNG 27 >>
|
|           +-----+           +-----+
+-----+ OR_ +-----+-----+ MOVE_ +-----+
|           | WORD |           | WORD |
|           |     |           |     |
| INTWD3 -+I1 Q+-ITABLE3 INTWD3 -+IN Q+-ITABLE3
|           | LEN |           | LEN |
|           |00001|           |00001|
| CONST -+I2 |           +-----+
| 3FFF +-----+
|
| << RUNG 28 >>
|
| USER :
|
| (*****
| (* User logic to be inserted here. A DOIO at the end of user logic on *)
| (* outputs associated with the interrupts is suggested for best thru-put.*)
| (*****
|
| << RUNG 30 >>
|
+ EXIT :
|
+[           END OF BLOCK LOGIC           ]

```

GFK-0880C
August 1997

Interrupt Module, 14 Point, 24 Volt DC Positive/Negative Logic

Table 1. Specifications for IC697MDL671 †

Rated Voltage:	24 volts DC
Inputs per Module:	14 interrupts (total of 16 inputs with four groups of four inputs each)
Isolation:	1500 volts - any input to backplane 500 volts between input groups
Input Voltage Range (V_s):	-3 to +30 volts DC
Input Current:	10mA (typical) at rated voltage
Input Impedance:	2.6K ohm, typical
Input Characteristics	
On-state Voltage:	Positive: 13.5 volts to 30 volts Negative: -3 volts to V _s -13.5 volts
On-state Current:	6mA to 15mA
Off-state Voltage:	Positive: -3 volts to 5 volts Negative: V _s -5 volts to 30 volts
Off-state Current:	0 to 2mA (2mA minimum at 5V input)
Filter Delay Time:	1 ms or 10 ms configurable
Minimum Pulse Width	1 ms Filter Select: 1 ms on and off 10 ms Filter Select: 11 ms on and off
Minimum Interrupt Burst (1 ms Filter Selection) †	
Single Point:	
with IC697CPM915 CPU	500 Hz
at 1 second PLC Watchdog Setting	
with IC697CPU731 CPU	290 Hz
at 2.5 seconds PLC Watchdog Setting	
Minimum Through-Put *	
Interrupt Input to Discrete Output Response	1.5 ms
with IC697CPM915 CPU and IC697MDL740	
Output Module with DOIO Function	
* Amount of user logic in the interrupt block may affect performance.	
Current Required from 5V Bus:	0.30 amp
VME	System designed to support the VME standard C.1

† Refer to GFK-0867B, or later for product standards and general specifications. For installations requiring compliance to more stringent requirements (for example, FCC or European Union Directives), refer to *Installation Requirements for Conformance to Standards*.

Table 2. Ordering Information

Description	Catalog Number
Interrupt Input Module, 24 Volt DC Positive/Negative Logic, 14 interrupt points (16 points total)	IC697MDL671

Note: For Conformal Coat option, or Low Temperature Testing option please consult the factory for price and availability.

Discrete Output Modules

IC697MDL350

GFK-0081H
August 1997

120 Volt AC 0.5 Amp, 32-Point Output Module

Features

- 32 Points - Four isolated groups of 8 points each
- 0.5 amp capacity per point
- High inrush capacity (20x rated current)

The **120 Volt AC 0.5 Amp Output Module** provides 32 output points in four isolated groups of 8 points each. This allows each group of 8 points to be used on a different phase of the AC supply. Each group of 8 outputs is individually fused with a 5 amp fuse.

The module provides a high degree of inrush current which makes the outputs suitable for a wide range of inductive and incandescent loads. The module will pick up most size 2 contactors.

LED indicators which give the ON-OFF status of each point on the logic (PLC) side of the circuits as well as an LED to indicate the status of the fuses are located together at the top of the module.

The module is mechanically keyed to ensure correct replacement with a similar type in the field. I/O references are user configurable without the use of jumpers or DIP switches on the module.

Configuration is done using the configuration function of the MS-DOS® or Windows® programming software running on Windows® 95 or Windows NT® over Ethernet TCP/IP or through the SNP port. The Programming Software configuration function is installed on the programming device. The programming device can be an IBM® XT, AT, PS/2® or compatible Personal Computer.

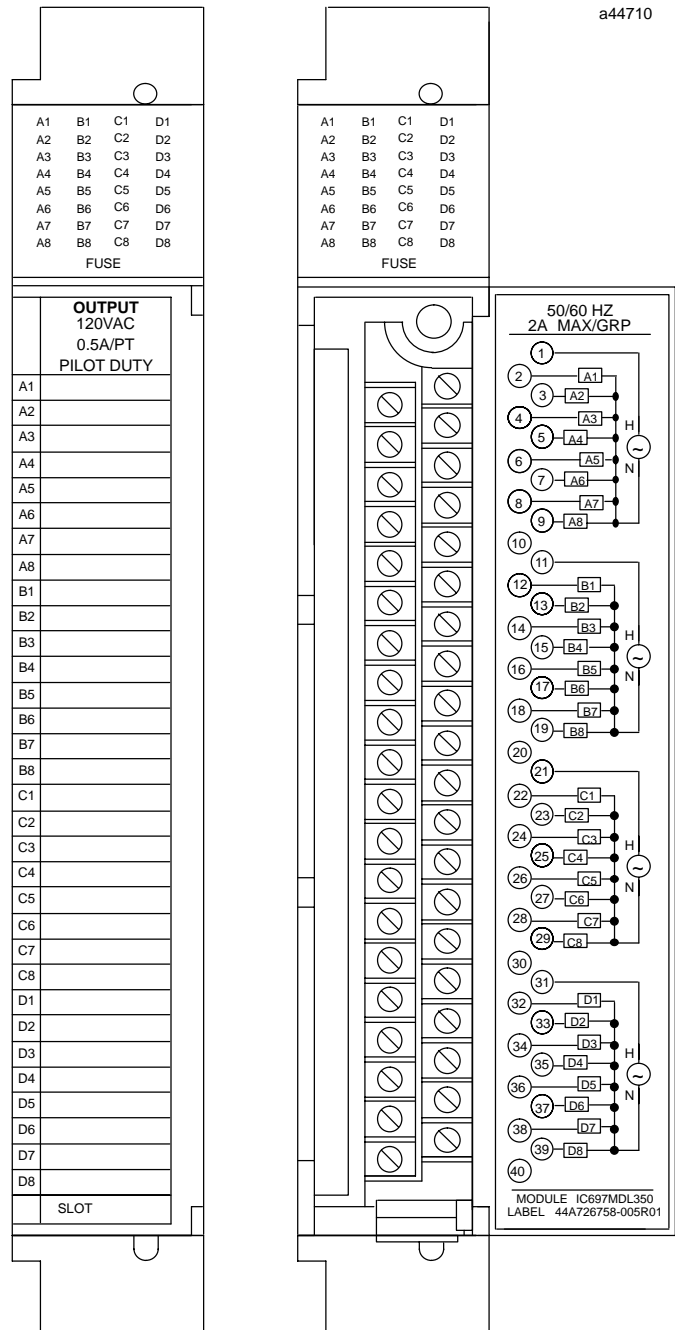

© IBM and PS/2 are registered trademarks of International Business Machines Corporation.

© MS-DOS, Windows, Windows 95, and Windows NT are registered trademarks of Microsoft Corporation.

GFK-0081H
August 1997

120 Volt AC 0.5 Amp, 32-Point Output Module

Operation of the 120 Volt AC 0.5 Amp Output Module

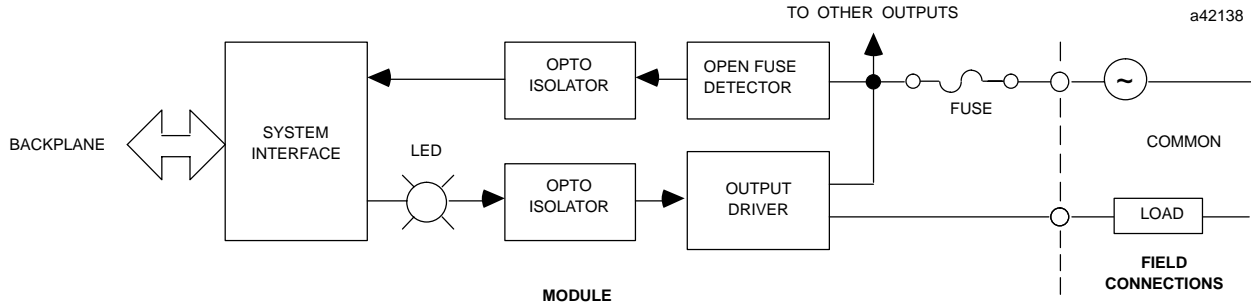

Figure 1. Block Diagram for IC697MDL350

Output Characteristics

The 120 Volt AC 0.5 Amp Output Module is compatible with a wide variety of load devices, such as:

- Solenoids and motor starters
- Indicators

The rating of 0.5 amps per point applies to the long-term current capacity of each point. Because of overall heat dissipation within the module, the maximum current capacity for each group of 8 outputs is limited at higher temperatures (refer to the specifications on the last page of this data sheet).

Each output on this module is capable of transiently conducting a surge current which is much greater than its long-term current rating.

The rate at which such surges can be repeated depends on the current rating of the device and the duty cycle (percent of time the device is ON). For typical incandescent devices operating at a 50% duty cycle, the following repetition rates apply.

Steady-state Current (mA)	Repetition Rate (Hz)
100	5
250	1
500	0.1

Fault Mode Selection

The module can be configured from the programmer so that output points assume one of two states in response to certain operating or default conditions.

- Maintain existing output state
- Turn outputs OFF

This is explained in more detail in the applicable *Programmable Controller Reference Manual*.

Fusing

Each group of 8 outputs is fused with a 5 amp fuse. Replaces with a 5 amp fuses. Replace with either of the following types:

- 3AG - 5 amp, 250V, Fast Acting
- Metric 5 x 20 mm - 5 amp, 250V, Fast Acting

Module Mechanical Keying

This module includes a mechanical key that prevents inadvertent substitution of one module type for another in a given slot. The key fits a uniquely shaped area on the board below the connector. The key is included with each module.

When the module is first installed, the key latches onto the backplane center rail. When the module is extracted, the key remains in the center rail, configuring the slot to accept only identical module types.

If it is necessary to change the module location in the rack after the key has been latched onto the center rail of the rack, the key can be removed by pushing it upward to unhook the latch while pulling it off the rail. It may then be reinstated onto the module and the module inserted into the rack in the desired location. Note: only the power supply can be placed in the left-most rack position.

Field Wiring

The module is wired as shown. Since each group of eight outputs is isolated from the others, a wire from the power source to the power input terminals for each group is required (power input terminals for each group are not connected inside the module).

The detachable field wiring terminal board will accept wire sizes from AWG #22 (0.36 mm²) through AWG #14 (2.10 mm²). Two wires may be terminated on a given lug if both wires are the same size. There is room for a bundle of forty AWG #14 wires to be routed out through the terminal board cavity.

The wire bundle can be secured to the terminal board by passing a cable tie through a cleat located at the lower corner of the terminal board.

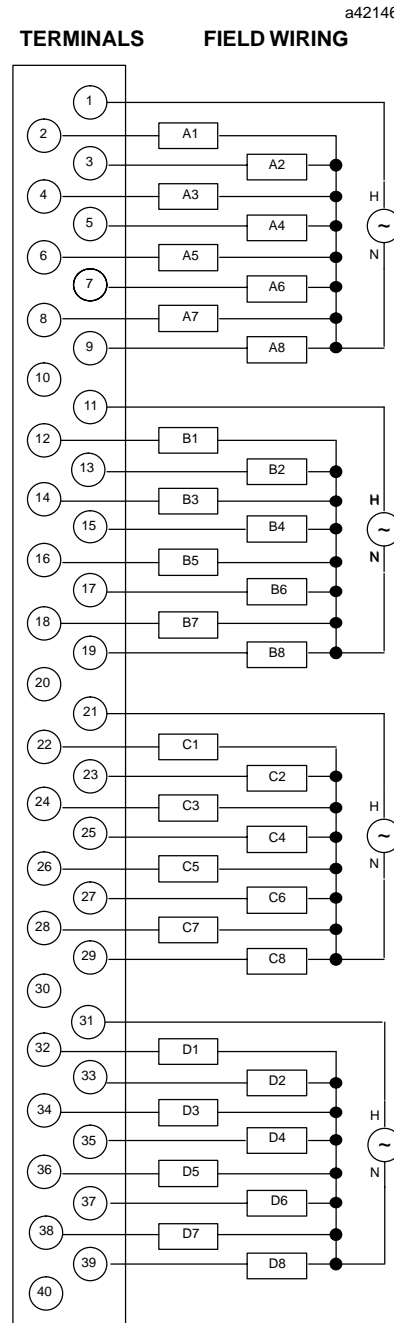

Figure 2. Field Wiring Connections

GFK-0081H
August 1997

120 Volt AC 0.5 Amp, 32-Point Output Module

Recommended Field Wiring Procedures

The following procedures are recommended when connecting field wiring to the detachable terminal

board on this input module. Module features referenced in the following procedures which are common to all IC697 I/O modules are illustrated in the following figure.

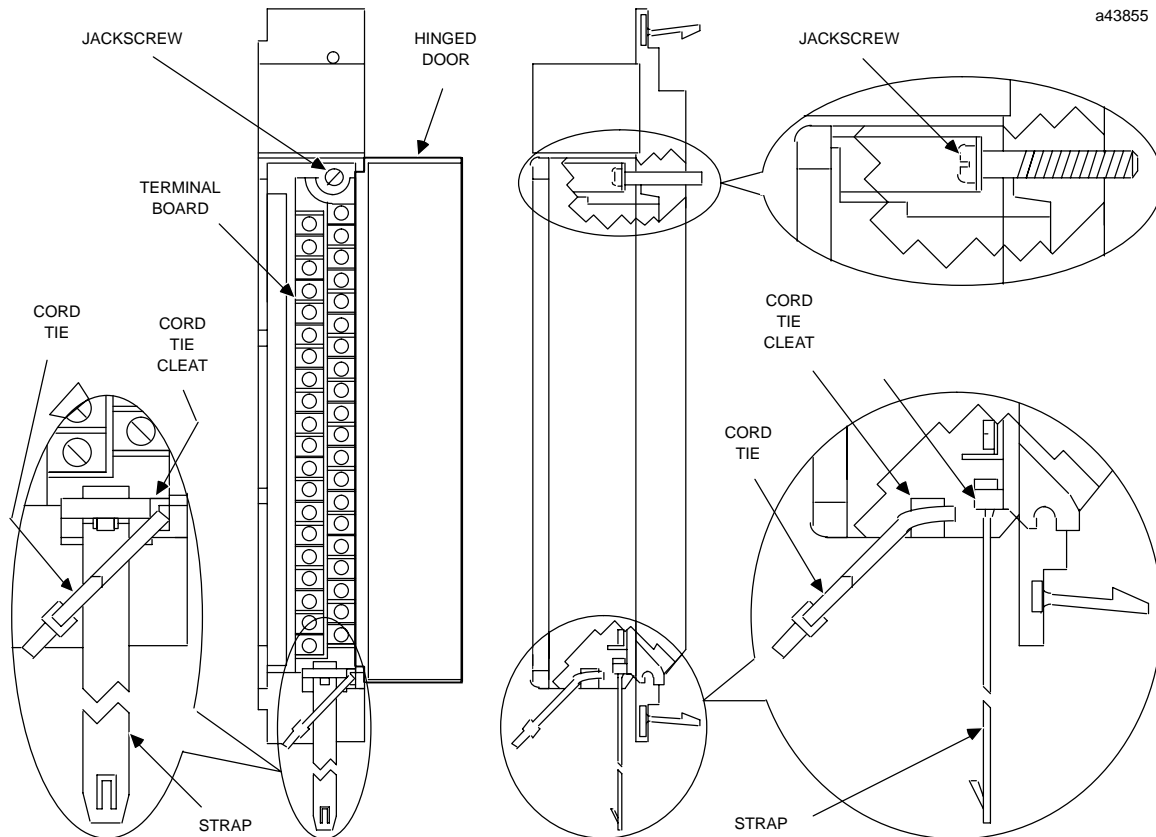

Figure 3. I/O Module Features

1. Turn off power before removing or installing terminal boards. Open the hinged door on the module to access a jackscrew which holds the terminal board securely in place. The detachable field wiring terminal board can now be removed from the module by turning the jackscrew counter-clockwise until it is fully disengaged.
2. To remove the terminal board, grasp the top of the terminal board and swing it outward as shown in Figure 4.
3. The terminal board is designed to accept wire sizes from AWG #22 (0.36 mm) through AWG #14 (2.1 mm). It is important that when using AWG #14 (2.1 mm²) wire for wiring all points, that a maximum insulation diameter of .135 inch (3.43mm) not be exceeded. To ensure proper connection, two wires may be terminated on any one terminal only if both wires are the same size.
4. The terminal board is designed to accept a maximum of (40) AWG #14 (2.1 mm²) wires. If AWG #14 (2.1 mm²) wires are to be used, then wire markers should be placed at least 8 inches (203 mm) from termination end to provide sufficient space for the hinged door to close.

Caution

Do not use the hinged door to remove the terminal board. The hinged door could be damaged if this is done.

120 Volt AC 0.5 Amp, 32-Point Output Module

GFK-0081H
August 1997

Figure 4. Removal of I/O Terminal Board

5. After completing connections to all modules in a rack, the wire bundle must be secured. To ensure that the wire bundle is secured properly, it is recommended that a cable tie be wrapped around the wire bundle and tightly secured through the cable tie cleat located at the lower right corner of the terminal board. For extremely large wire bundles, additional cable ties should be used.
6. A door label insert is included with each module to indicate circuit wiring information and provide space to record user circuit wiring identification. A slot is provided on the hinged door to allow for insertion of this label. If the label is difficult to insert, crease the scored edge before insertion. The outside label has a color coded stripe to allow quick identification of the module voltage type (blue: low voltage; red: high voltage).
7. After field wiring is completed, the terminal board should be securely fastened to the rack by inserting the terminal board strap (attached to each module) into the small rectangular slots in the bottom card guide grill on the rack. This strap not

only secures the terminal board to the rack, it also provides a way of identifying the wired terminal board with its correct mating rack slot location.

8. For adequate module ventilation, it is recommended that at least a 6 inch (152mm) clearance be allowed above and below the rack grill. Wire bundles should not obstruct the rack grill work.

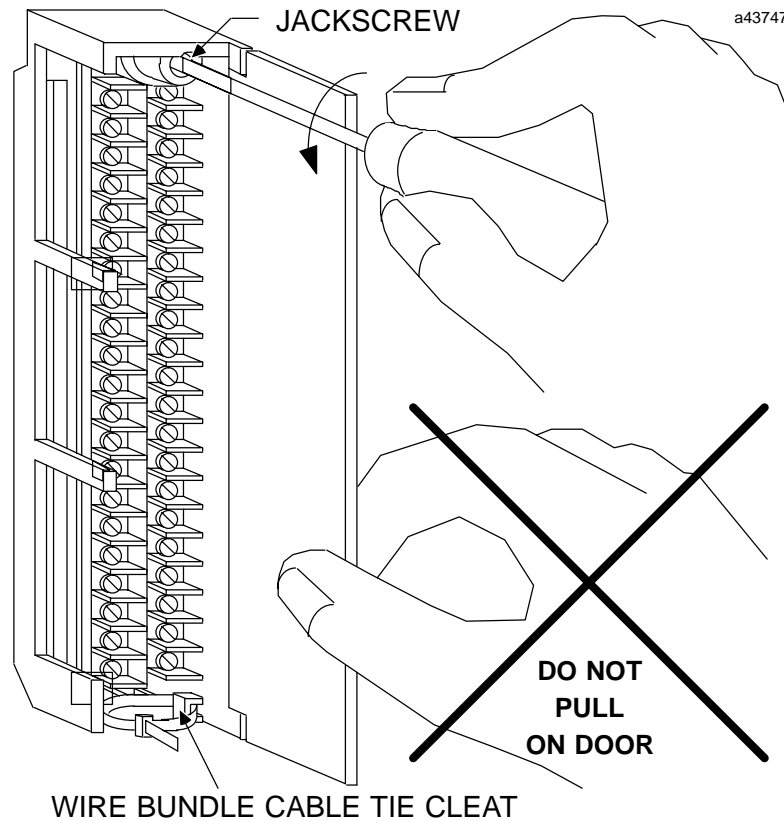
Removing an I/O Module

The instructions below should be followed when removing an I/O module from its slot in a rack.

- Grasp the board firmly at the top and bottom of the board cover with your thumbs on the front of the cover and your fingers on the plastic clips on the back of the cover.
- Squeeze the rack clips on the back of the cover with your fingers to disengage the clip from the rack rail and pull the board firmly to remove it from the backplane connector.
- Slide the board along the card guide and remove it from the rack.

GFK-0081H
August 1997

120 Volt AC 0.5 Amp, 32-Point Output Module

Table 1. Specifications for IC697MDL350 †

Rated Voltage:	120 volts AC
Outputs per Module:	32 (four groups of 8 outputs each)
Isolation:	1500 volts - any output to backplane 500 volts between groups
Output Voltage Range:	85 to 132 volt, 47-63 Hz
Output Current:	0.5 amps maximum per point 2 amps maximum per group
Output Characteristics -	
Inrush Current:	10 amps maximum per point for one cycle (20 ms)
Output Voltage Drop:	3 volts maximum
Response Time-On:	1 ms maximum
Response Time-Off:	1/2 cycle
Output Leakage:	1.5 mA maximum
Current Required from 5V Bus:	0.5 amp
VME	System designed to support the VME standard C.1

† Refer to GFK-0867B, or later for product standards and general specifications. For installations requiring compliance to more stringent requirements (for example, FCC or European Union Directives), refer to *Installation Requirements for Conformance to Standards*.

Table 2. Ordering Information

Description	Catalog Number
Output Module - 120 Volt AC 0.5 Amp, 32 Points	IC697MDL350

Note: For Conformal Coat option, or Low Temperature Testing option please consult the factory for price and availability.

GFK-0082H
August 1997

120 Volt AC 2 Amp, 16-Point Output Module

Operation of the 120 Volt AC 2 AMP Output Module

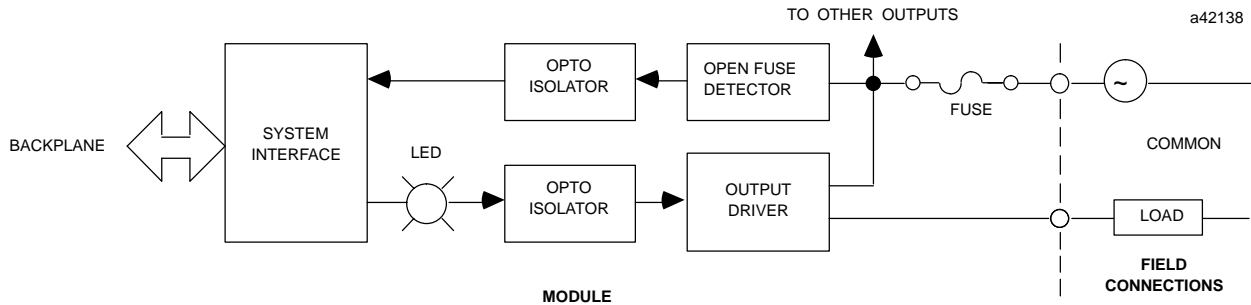

Figure 1. Block Diagram for IC697MDL340

Output Characteristics

The 120 Volt AC 2 Amp Output Module is compatible with a wide variety of load devices, such as:

- Solenoids and motor starters
- Indicators

The rating of 2 amps per point applies to the long-term capacity of each point. Because of overall heat dissipation within the module, the maximum current capacity for each group of four outputs is limited to 4 amperes.

Each output on this module is capable of transiently conducting a surge current which is much greater than its long-term current rating.

The rate at which such surges can be repeated depends on the current rating of the device and the duty cycle (percent of time the device is ON). For typical incandescent devices operating at a 50% duty cycle, the following repetition rates apply.

Steady-state Current (mA)	Repetition Rate (Hz)
0.5	5
1	1
2	0.1

Fault Mode Selection

The module can be configured from the programmer so that output points assume one of two states in response to certain operating or default conditions.

- Maintain existing output state
- Turn outputs OFF

This is explained in more detail in the programming manual.

Fusing

Each group of 4 outputs is fused with a 10 amp fuse. Replace with either of the following types:

- 3AG - 10 amp, 250V, Fast Acting
- Metric 5 x 20 mm - 10 amp, 250V, Fast Acting

Module Mechanical Keying

This module includes a mechanical key that prevents inadvertent substitution of one module type for another in a given slot. The key fits a uniquely shaped area on the board below the connector. The key is included with each module.

When the module is first installed, the key latches onto the backplane center rail. When the module is extracted, the key remains in the center rail, configuring the slot to accept only identical module types.

If it is necessary to change the module location in the rack after the key has been latched onto the center rail of the rack, the key can be removed by pushing it upward to unhook the latch while pulling it off the rail. It may then be reinserted onto the module and the module inserted into the rack in the desired location. Note: only the power supply can be placed in the left-most rack position.

Field Wiring

The module is wired as shown. Since each group of four outputs is isolated from the others, a wire from the power source to the power input terminals for each group is required (power input terminals for each group are not connected inside the module).

The detachable field wiring terminal board will accept wire sizes from AWG #22 (0.36 mm²) through AWG #14 (2.10 mm²). Two wires may be terminated on a given lug if both wires are the same size. There is room for a bundle of forty AWG #14 (2.10 mm²) wires to be routed out through the terminal board cavity.

The wire bundle can be secured to the terminal board by passing a cable tie through a cleat located at the lower corner of the terminal board.

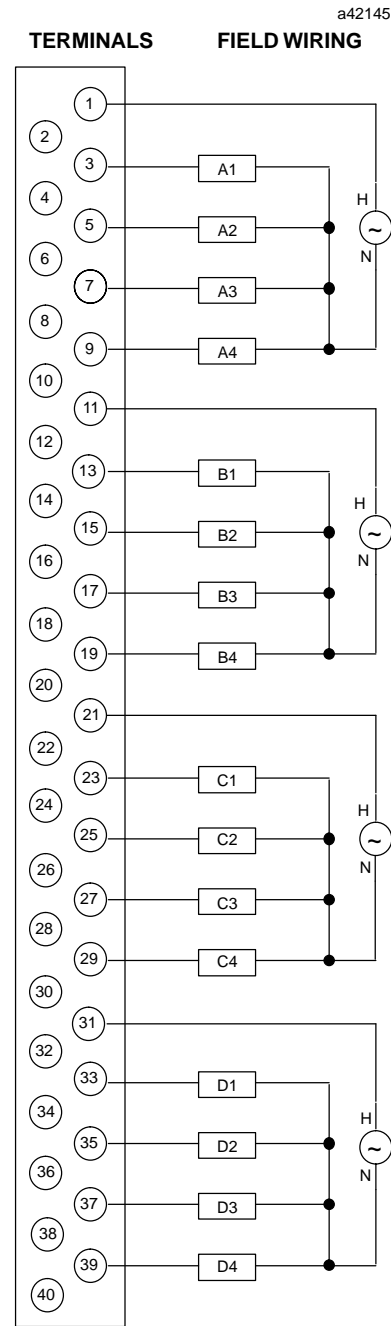

Figure 2. Field Wiring Connections

GFK-0082H
August 1997

120 Volt AC 2 Amp, 16-Point Output Module

Recommended Field Wiring Procedures

The following procedures are recommended when connecting field wiring to the detachable terminal

board on this input module. Module features referenced in the following procedures which are common to all IC697 I/O modules are illustrated in the following figure.

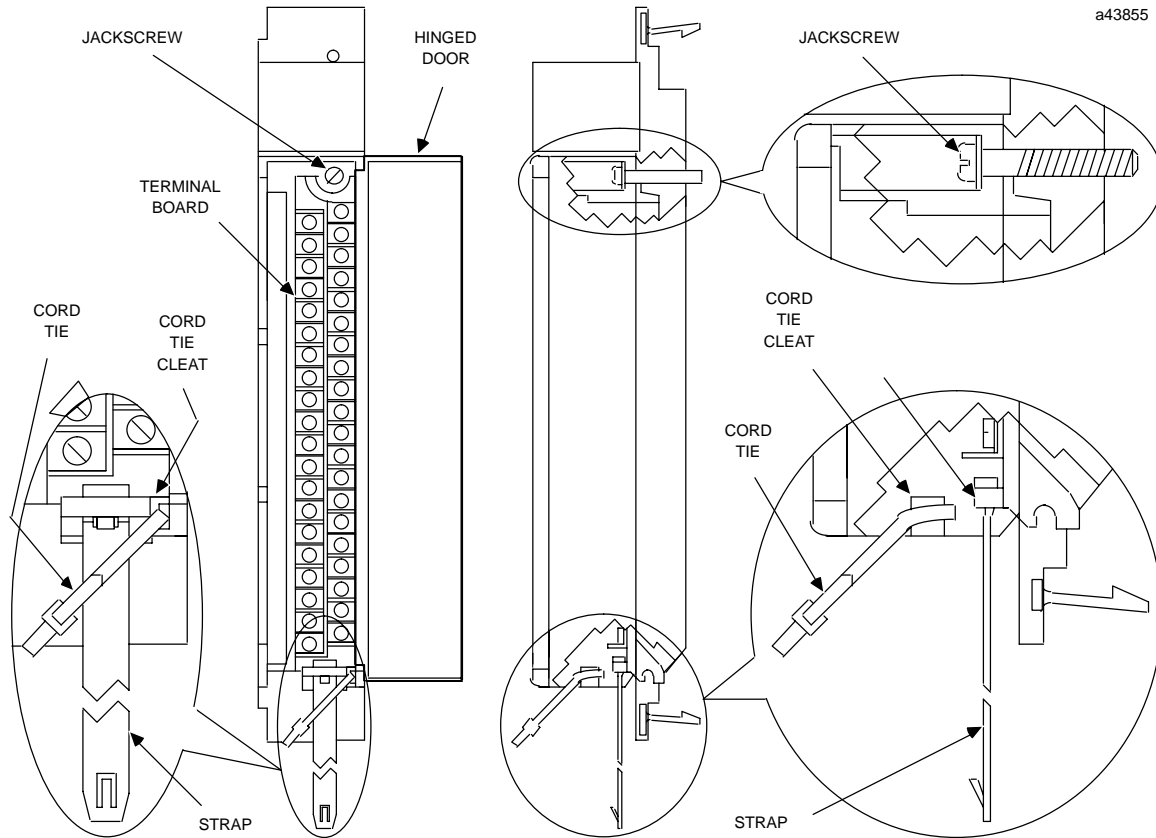

Figure 3. I/O Module Features

1. Turn off power before removing or installing terminal boards. Open the hinged door on the module to access a jackscrew which holds the terminal board securely in place. The detachable field wiring terminal board can now be removed from the module by turning the jackscrew counter-clockwise until it is fully disengaged.
2. To remove the terminal board, grasp the top of the terminal board and swing it outward as shown in Figure 4.
3. The terminal board is designed to accept wire sizes from AWG #22 (0.36 mm) through AWG #14 (2.10 mm). It is important that when using AWG #14 (2.10 mm²) wire for wiring all points, that a maximum insulation diameter of .135 inch (3.43mm) not be exceeded. To ensure proper connection, two wires may be terminated on any one terminal only if both wires are the same size.
4. The terminal board is designed to accept a maximum of (40) AWG #14 (2.10 mm²)wires. If AWG #14 (2.10 mm²) wires are to be used, then wire markers should be placed at least 8 inches (203 mm) from termination end to provide sufficient space for the hinged door to close.

Caution

Do not use the hinged door to remove the terminal board. The hinged door could be damaged if this is done.

120 Volt AC 2 Amp, 16-Point Output Module

GFK-0082H
August 1997

Figure 4. Removal of I/O Terminal Board

5. After completing connections to all modules in a rack, the wire bundle must be secured. To ensure that the wire bundle is secured properly, it is recommended that a cable tie be wrapped around the wire bundle and tightly secured through the cable tie cleat located at the lower right corner of the terminal board. For extremely large wire bundles, additional cable ties should be used.
6. A door label insert is included with each module to indicate circuit wiring information and provide space to record user circuit wiring identification. A slot is provided on the hinged door to allow for insertion of this label. If the label is difficult to insert, crease the scored edge before insertion. The outside label has a color coded stripe to allow quick identification of the module voltage type (blue: low voltage; red: high voltage).
7. After field wiring is completed, the terminal board should be securely fastened to the rack by inserting the terminal board strap (attached to each module) into the small rectangular slots in the bottom card guide grill on the rack. This strap not

only secures the terminal board to the rack, it also provides a way of identifying the wired terminal board with its correct mating rack slot location.

8. For adequate module ventilation, it is recommended that at least a 6 inch (152mm) clearance be allowed above and below the rack grill. Wire bundles should not obstruct the rack grill work.

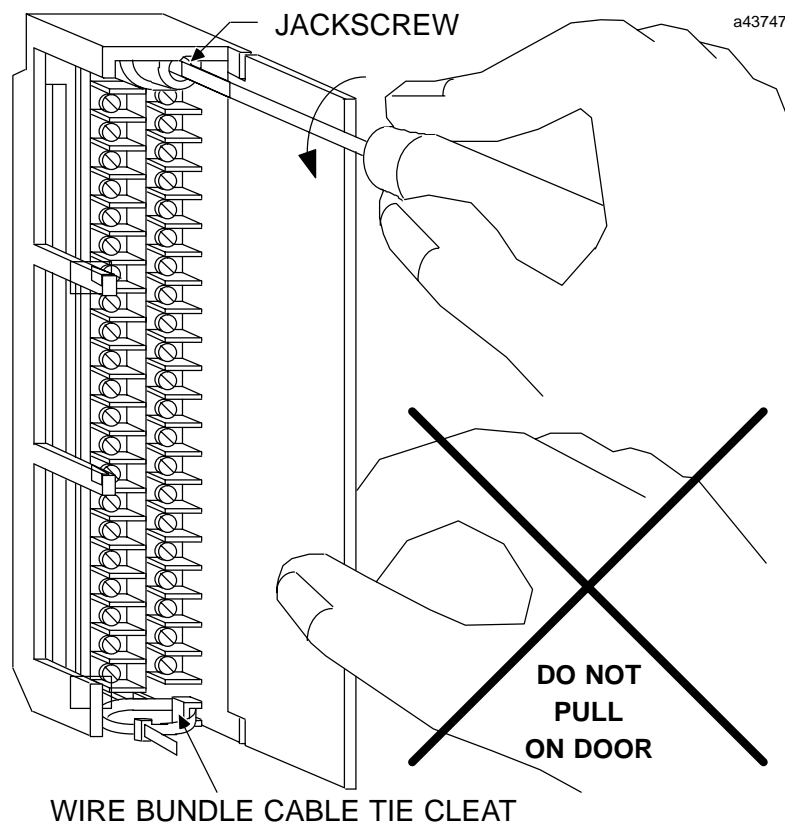
Removing an I/O Module

The instructions below should be followed when removing an I/O module from its slot in a rack.

- Grasp the board firmly at the top and bottom of the board cover with your thumbs on the front of the cover and your fingers on the plastic clips on the back of the cover.
- Squeeze the rack clips on the back of the cover with your fingers to disengage the clip from the rack rail and pull the board firmly to remove it from the backplane connector.
- Slide the board along the card guide and remove it from the rack.

GFK-0082H
August 1997

120 Volt AC 2 Amp, 16-Point Output Module

Table 1. Specifications for IC697MDL340 †

Rated Voltage:	120 volts AC
Outputs per Module:	16 (four groups of four outputs each)
Isolation:	1500 volts - any output to backplane 500 volts between groups
Output Voltage Range:	85 to 132 volts, 47 to 63 Hz
Output Current:	2 amps maximum per point 4 amps maximum per group
Output Characteristics-	
Inrush Current:	20 amps maximum for one cycle (20 ms)
Output Voltage Drop:	3 volts maximum
Response Time-On:	1 ms maximum
Response Time-Off:	1/2 cycle
Output Leakage:	1.5 mA maximum
Current Required from 5V Bus:	0.25 amp
VME	System designed to support the VME standard C.1

† Refer to GFK-0867B, or later for product standards and general specifications. For installations requiring compliance to more stringent requirements (for example, FCC or European Union Directives), refer to *Installation Requirements for Conformance to Standards*.

Table 2. Ordering Information

Description	Catalog Number
Output Module - 120 Volt AC 2 Amp, 16 Points	IC697MDL340

Note: For Conformal Coat option, or Low Temperature Testing option please consult the factory for price and availability.

Discrete Output Modules

IC697MDL341

GFK-0382J
August 1997

120/240 Volt AC, 2 Amp Isolated 12-Point Output Module

Features

- 12 individually isolated points
- 2 amp capacity per point
- High inrush capacity (10x rated current)

Functions

The 120/240 Volt AC 2 Amp Isolated Output Module for use with a Programmable Logic Controller (PLC) provides 12 isolated output points. This allows each point to be used on different phases of the AC supply. Each output point is individually fused with a 3.15 amp replaceable fuse.

The module provides a high degree of inrush current which makes the outputs suitable for a wide range of inductive and incandescent loads. The module will operate most size 4 contactors.

LED indicators which give the ON - OFF status of each point on the logic (PLC) side of the circuit as well as an LED to indicate the status of the fuses are located at the top of the module. If one or more of the fuses should blow, this LED will turn ON.

The module is mechanically keyed to ensure correct replacement with a similar module type in the field. I/O references are user configurable without the use of jumpers or DIP switches on the module.

Configuration is done using the configuration function of the MS-DOS® or Windows® programming software running on Windows® 95 or Windows NT® over Ethernet TCP/IP or through the SNP port. The Programming Software configuration function is installed on the programming device. The programming device can be an IBM® XT, AT, PS/2® or compatible Personal Computer.

Although this module is configured as a 16 point output, only outputs 1 through 12 are available to be referenced in your program. For example, if the starting reference is Q0017, then valid references are Q0017 through Q0028.

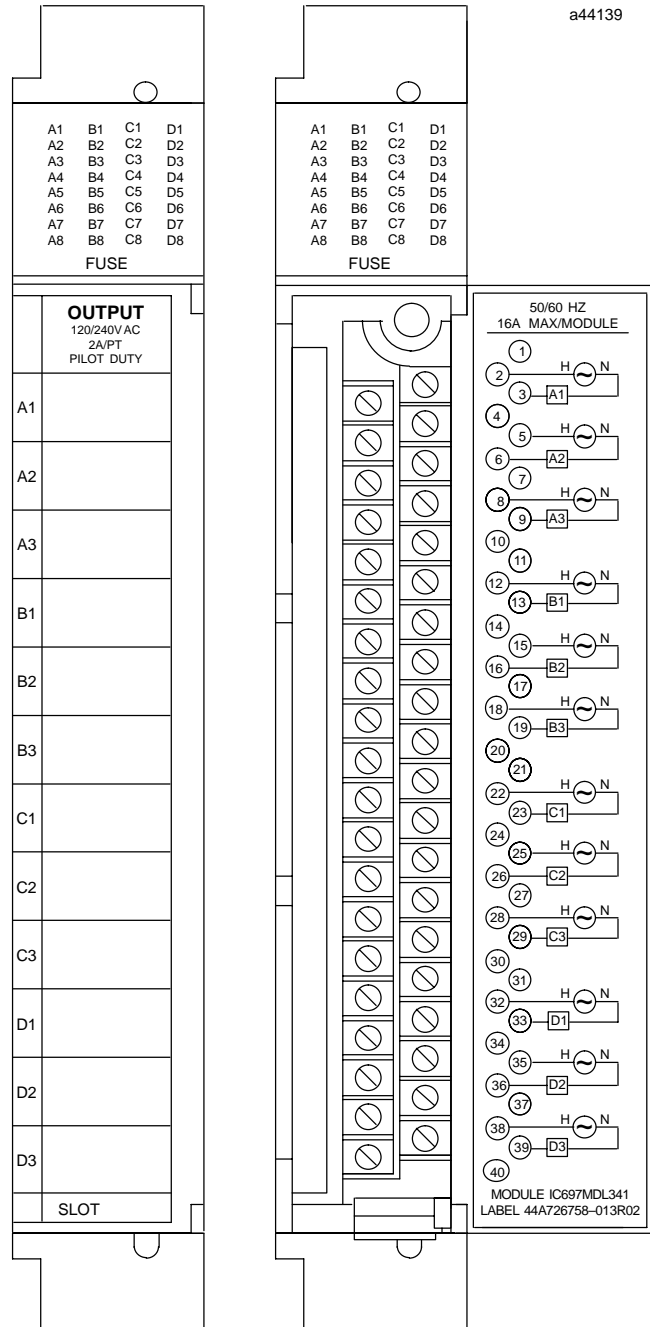

® IBM and PS/2 are registered trademarks of International Business Machines Corporation.

® MS-DOS, Windows, Windows 95, and Windows NT are registered trademarks of Microsoft Corporation.

GFK-0382J
August 1997

120/240 Volt AC, 2 Amp Isolated 12-Point Output Module

Operation - 120/240 Volt AC 2 Amp Isolated Output Module

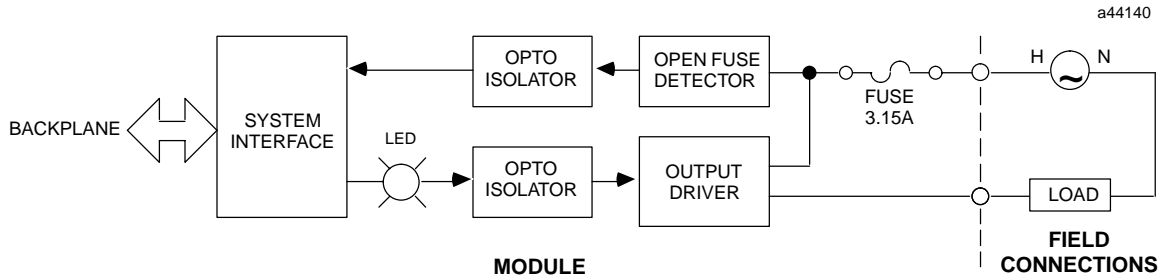

Figure 1. Block Diagram for IC697MDL341

Output Characteristics

The 120/240 Volt AC 2 Amp Isolated Output Module is compatible with a wide variety of load devices, such as:

- Solenoids
- Motor starters
- Indicators

The rating of 2 amps per point applies to the long-term current capacity of each point. Because of overall heat dissipation within the module, the maximum current for the module is limited to 16 amperes.

Each output on this module is capable of transiently conducting a surge current which is much greater than its long-term current rating. The rate at which such surges can be repeated depends on the current rating of the device and the duty cycle (percent of time the device is ON).

For typical incandescent devices operating at a 50% duty cycle, the following repetition rates apply to this module.

Steady-State Current (mA)	Repetition Rate (Hz)
0.5	5
1	1
2	0.1

Fault Mode Selection

This output module can be configured from the programmer so that output points assume one of two states in response to certain operating or default conditions. These states are:

- Maintain existing output state
- Turn outputs OFF

For more detailed information on module configuration, refer to the Programming Software User's Manual for IC641 software products.

Fusing

Each output is fused with a replaceable 3.15 amp fuse. Replace with the following type:

- Metric 5 x 20 mm - 3.15 amp, 250V, Slo-blo

Module Mechanical Keying

This module includes a mechanical key that prevents inadvertent substitution of one module type for another in a given slot. The key fits a uniquely shaped area on the board below the connector. Each module has a key packaged with it.

When the module is first installed, the key latches onto the backplane center rail. When the module is extracted, the key remains in the center rail, configuring the slot to accept only identical module types.

If it is necessary to change the module location in the rack after the key has been latched onto the center rail of the rack, the key can be removed by pushing it upward to unhook the latch while pulling it off the rail. It may then be reinserted onto the module and the module inserted into the rack in the desired location.

Note that only a power supply can be placed in the left-most rack position, and slot 1 (adjacent to the power supply) must always contain a CPU (in rack 0 - the CPU rack), or a Bus Receiver Module (in an expansion rack).

120/240 Volt AC, 2 Amp Isolated 12-Point Output Module

GFK-0382J
August 1997

Field Wiring

The module is wired as shown in Figure 2. Since each output is isolated from the other outputs, a wire from the power source to the power input terminal for each output is required (power input terminals for each output are not connected inside the module).

The detachable field wiring terminal board will accept wire sizes from #22 (0.36 mm²) through #14 (2.10 mm²). Two wires may be terminated on a given lug if both wires are the same size. There is room for a bundle of forty #14 (2.10 mm²) wires to be routed out through the terminal board cavity.

The wire bundle can be secured to the terminal board by passing a cable tie through a cleat located at the lower corner of the terminal board.

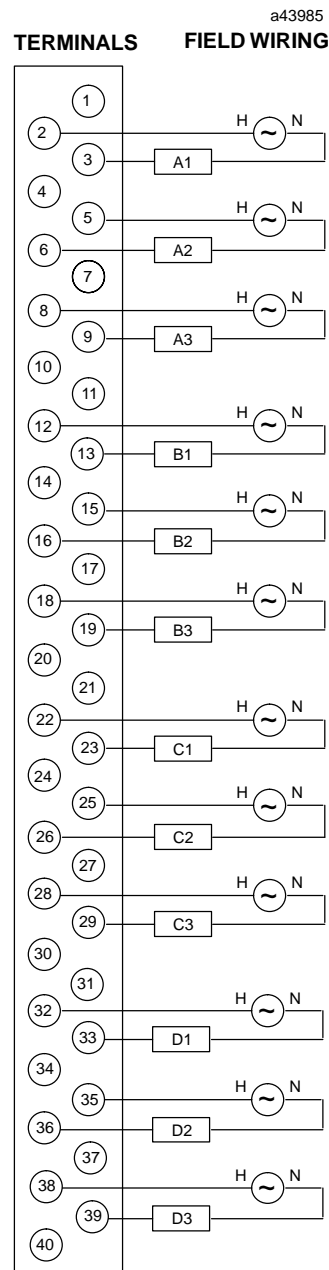

Figure 2. Field Wiring Connections

GFK-0382J
August 1997

120/240 Volt AC, 2 Amp Isolated 12-Point Output Module

Recommended Field Wiring Procedures

The following procedures are recommended when connecting field wiring to the detachable terminal board on this input

module. Module features referenced in the following procedures which are common to all IC697 I/O modules are illustrated in the following figure.

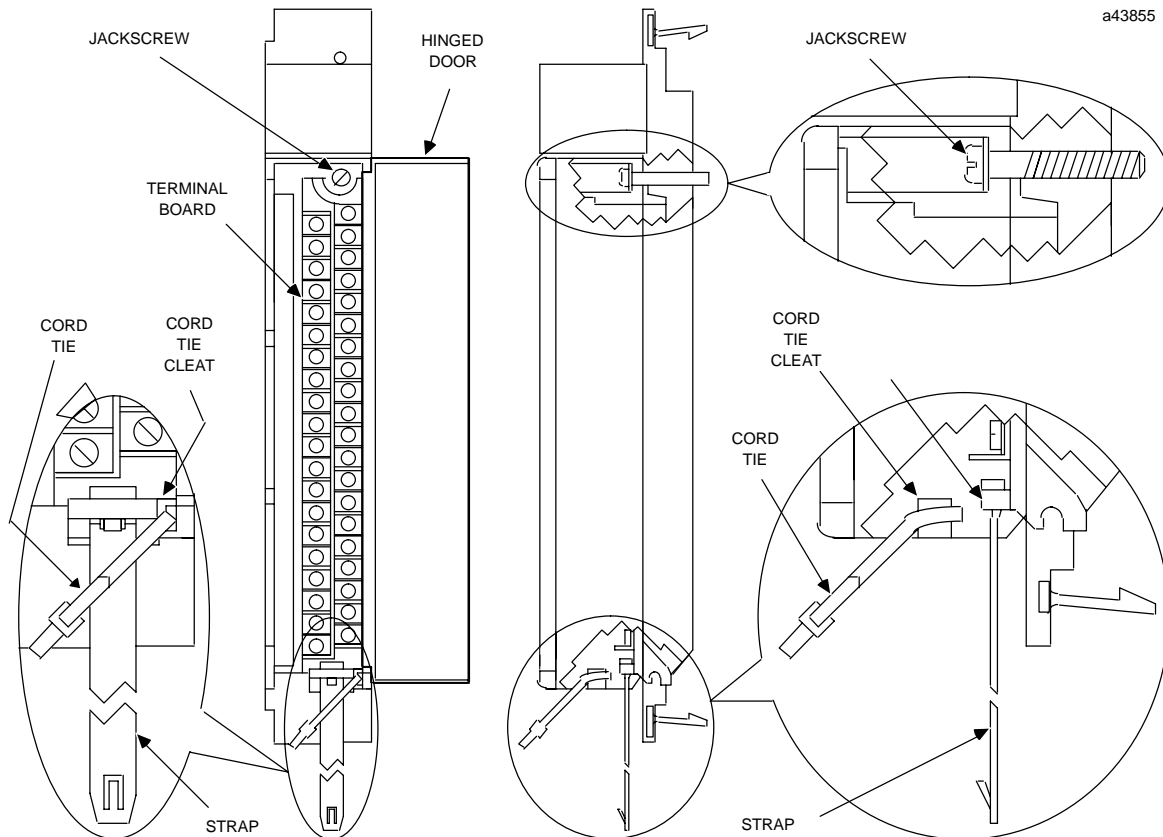

Figure 3. I/O Module Features

1. Turn off power before removing or installing terminal boards. Open the hinged door on the module to access a jackscrew which holds the terminal board securely in place. The detachable field wiring terminal board can now be removed from the module by turning the jackscrew counter-clockwise until it is fully disengaged.
2. To remove the terminal board, grasp the top of the terminal board and swing it outward as shown in Figure 4.
3. The terminal board is designed to accept wire sizes from AWG #22 (0.36 mm) through AWG #14 (2.10 mm²). It is important that when using AWG #14 (2.10 mm²) wire for wiring all points, that a maximum insulation diameter of .135 inch (3.43) not be exceeded. To ensure proper connection, two wires may be terminated on any one terminal only if both wires are the same size.
4. The terminal board is designed to accept a maximum of (40) AWG #14 (2.10 mm²) wires. If AWG #14 (2.10 mm²) wires are to be used, then wire markers should be placed at least 8 inches (203 mm) from termination end to provide sufficient space for the hinged door to close.

Caution

Do not use the hinged door to remove the terminal board. The hinged door could be damaged if this is done.

120/240 Volt AC, 2 Amp Isolated 12-Point Output Module

GFK-0382J
August 1997

Figure 4. Removal of I/O Terminal Board

5. After completing connections to all modules in a rack, the wire bundle must be secured. To ensure that the wire bundle is secured properly, it is recommended that a cable tie be wrapped around the wire bundle and tightly secured through the cable tie cleat located at the lower right corner of the terminal board. For extremely large wire bundles, additional cable ties should be used.
6. A door label insert is included with each module to indicate circuit wiring information and provide space to record user circuit wiring identification. A slot is provided on the hinged door to allow for insertion of this label. If the label is difficult to insert, crease the scored edge before insertion. The outside label has a color coded stripe to allow quick identification of the module voltage type (blue: low voltage; red: high voltage).
7. After field wiring is completed, the terminal board should be securely fastened to the rack by inserting the terminal board strap (attached to each module) into the small rectangular slots in the bottom card guide grill on the rack. This strap not

only secures the terminal board to the rack, it also provides a way of identifying the wired terminal board with its correct mating rack slot location.

8. For adequate module ventilation, it is recommended that at least a 6 inch (152mm) clearance be allowed above and below the rack grill. Wire bundles should not obstruct the rack grill work.

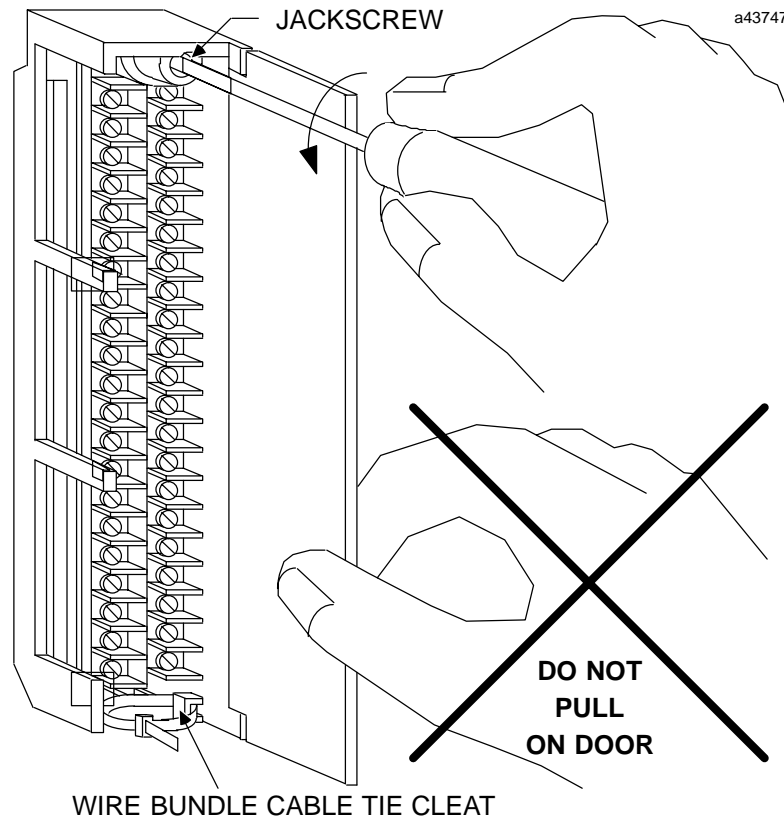
Removing an I/O Module

The instructions below should be followed when removing an I/O module from its slot in a rack.

- Grasp the board firmly at the top and bottom of the board cover with your thumbs on the front of the cover and your fingers on the plastic clips on the back of the cover.
- Squeeze the rack clips on the back of the cover with your fingers to disengage the clip from the rack rail and pull the board firmly to remove it from the backplane connector.
- Slide the board along the card guide and remove it from the rack.

GFK-0382J
August 1997

120/240 Volt AC, 2 Amp Isolated 12-Point Output Module

Table 1. Specifications for IC697MDL341 †

Rated Voltage:	120/240 volts AC
Outputs per Module:	12 individually isolated
Isolation:	1500 volts - any output to backplane 500 volts between points
Output Voltage Range:	85 to 264 volts AC, 47-63 Hz
Output Current:	2 amps maximum per point 16 amps maximum per module
Output Characteristics	
Inrush Current:	20 amps maximum for one cycle (20 ms)
Output Voltage Drop:	1.5 volts maximum
Response Time-On:	1 ms maximum
Response Time-Off:	1/2 cycle maximum
Output Leakage:	3 mA maximum at 120 volts AC 6 mA maximum at 240 volts AC
Current Required from 5 V Bus:	.25 amp
VME	System designed to support the VME standard C.1

† Refer to GFK-0867B, or later for product standards and general specifications. For installations requiring compliance to more stringent requirements (for example, FCC or European Union Directives), refer to *Installation Requirements for Conformance to Standards*.

Table 2. Ordering Information

Description	Catalog Number
OutputModule, 120/240VAC, 2 Amp Isolated, 12 Points	IC697MDL341

Note: For Conformal Coat option, or Low Temperature Testing option please consult the factory for price and availability.

Discrete Output Modules

IC697MDL753

GFK-0383F
August 1997

5/48 Volt DC 0.5 Amp Negative Logic, 32-Point Output Module

Features

- 32 Points - Two isolated groups of 16 points each
- 0.5 amp capacity per point
- High inrush capacity (10x rated current)

Functions

The **5/48 Volt DC 0.5 Amp Negative Logic Output Module** provides 32 output points in two isolated groups with 16 points in each group.

This is a wide range module in that the rated voltage can be 5 volts DC or 10 to 60 volts DC. It provides a high degree of inrush current at 10 volts to 60 volts which makes the outputs suitable for a wide range of loads which have such characteristics. It also operates at TTL levels.

LED indicators which give the ON - OFF status of each point on the logic (PLC) side of the circuit are located at the top of the module.

The module is mechanically keyed to ensure correct replacement with a similar module type in the field. I/O references are user configurable without the use of jumpers or DIP switches on the module.

Configuration is done using the configuration function of the MS-DOS® or Windows programming software running on Windows® 95 or Windows NT® over Ethernet TCP/IP or through the SNP port. The Programming Software configuration function is installed on the programming device. The programming device can be an IBM® XT, AT, PS/2® or compatible Personal Computer.

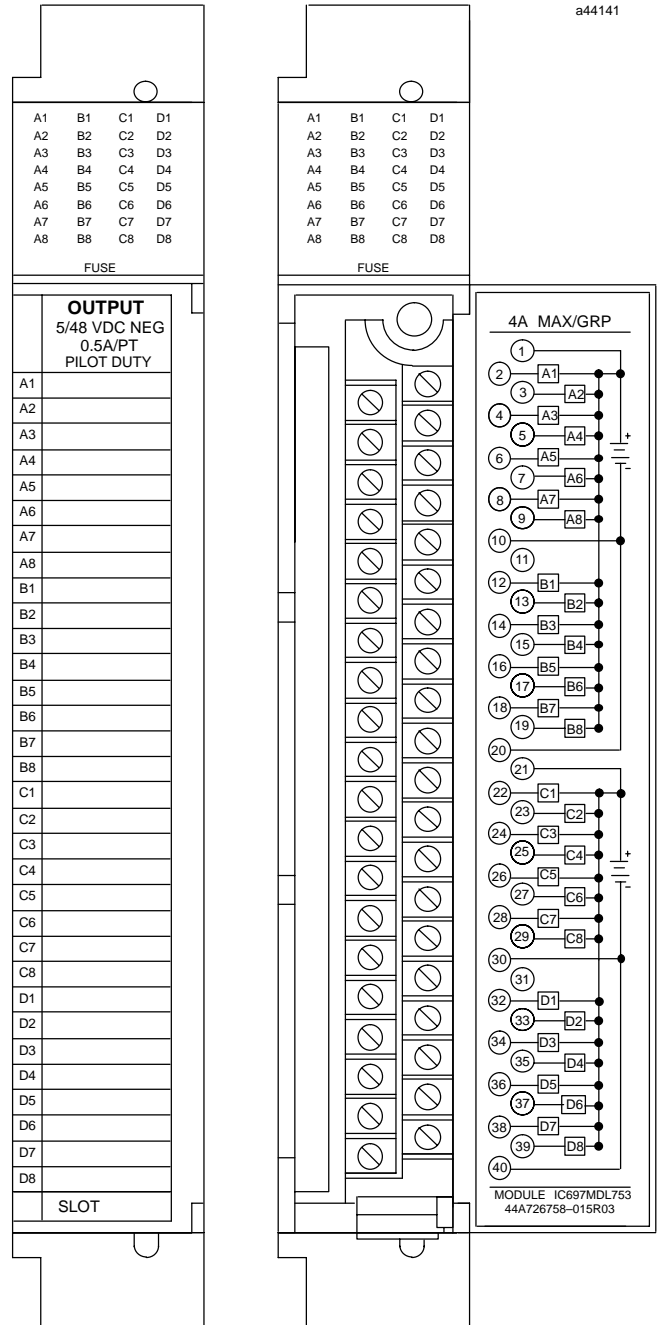

® IBM and PS/2 are registered trademarks of International Business Machines Corporation.

® MS-DOS, Windows, Windows 95, and Windows NT are registered trademarks of Microsoft Corporation.

GFK-0383F
August 1997

5/48 Volt DC 0.5 Amp Negative Logic, 32-Point Output Module

Operation - 5/48 Volt DC 0.5 Amp Negative Logic Output Module

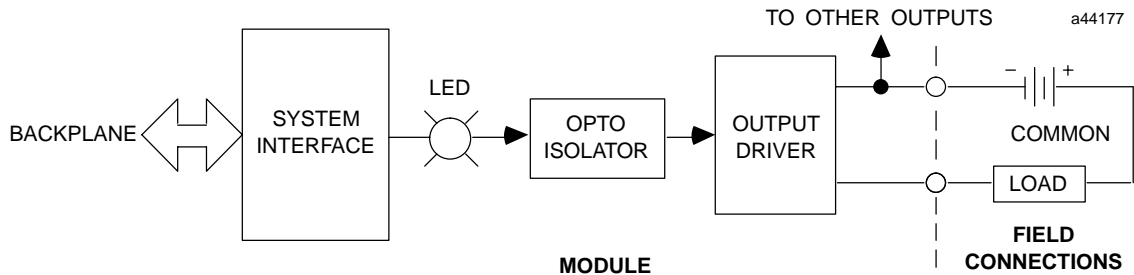

Figure 1. Block Diagram for IC697MDL753

Output Characteristics

The 5/48 Volt DC 0.5 Amp Negative Logic Output Module is compatible with a wide variety of load devices, such as:

- Solenoids
- Motor starters
- Indicators
- TTL interface

The rating of 0.5 amp per point applies to the long-term current capacity of each point. Because of overall heat dissipation within the module, the maximum current for each group of 16 outputs is limited to 4 amperes.

Each output on this module is capable of transiently conducting a surge current which is much greater than its long-term current rating. The rate at which such surges can be repeated depends on the current rating of the device and the duty cycle (percent of time the device is ON).

For typical incandescent devices operating at a 50% duty cycle, the following repetition rates apply to this module.

Steady-state Current (mA)	Repetition Rate (Hz)
100	5.0
250	1.0
500	0.1

Fault Mode Selection

This output module can be configured from the programmer so that output points assume one of two states in response to certain operating or default conditions. These states are:

- Maintain existing output state
- Turn outputs OFF

For more detailed information on module configuration, refer to the applicable *Programming Software User's Manual*.

Fusing

The 5/48 VDC 0.5 Amp Negative Logic Output Module has no replaceable fuses. If protection is required, a fuse as specified below may be externally connected to each output point by the user.

- Littlefuse 312.750 (3/4 amp, 250 volt), Fast Acting
- Bussmann AGC-3A (3A amp, 250 volt), Fast Acting

Module Mechanical Keying

This module includes a mechanical key that prevents inadvertent substitution of one module type for another in a given slot. The key fits a uniquely shaped area on the board below the connector. Each module has a key packaged with it.

When the module is first installed, the key latches onto the backplane center rail. When the module is extracted, the key remains in the center rail, configuring the slot to accept only identical module types.

If it is necessary to change the module location in the rack after the key has been latched onto the center rail of the rack, the key can be removed by pushing it upward to unhook the latch while pulling it off the rail. It may then be reinserted onto the module and the module inserted into the rack in the desired location.

Note that only a power supply can be placed in the leftmost rack position, and slot 1 (adjacent to the power supply) must always contain a CPU (in rack 0 - the CPU rack), or a Bus Receiver Module (in an expansion rack).

Field Wiring

The module is wired as shown in Figure 2. Since each group of 16 outputs is isolated from the other group, a wire from the power source to the power input terminals for each group is required (power input terminals for each group are not connected inside the module).

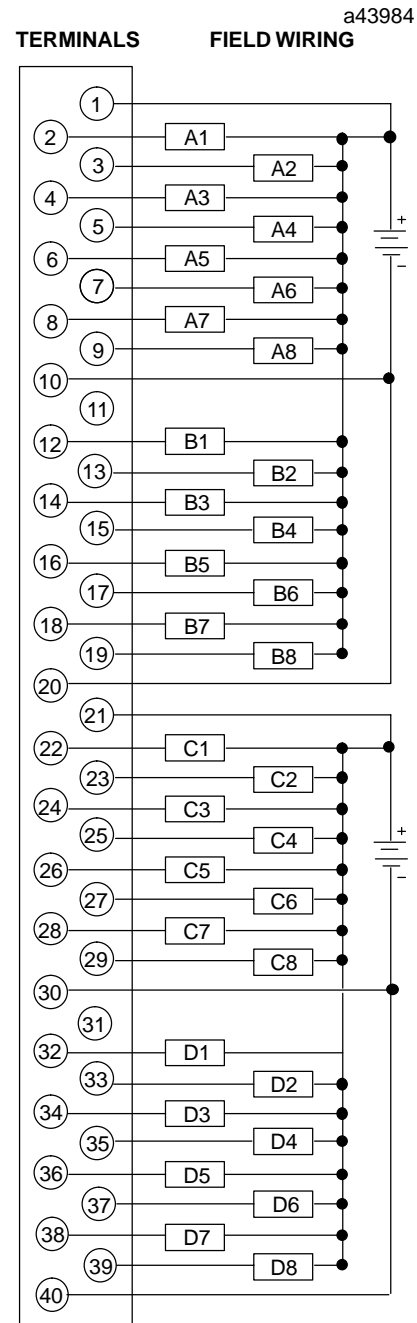

Figure 2. Field Wiring Connections

GFK-0383F
August 1997

5/48 Volt DC 0.5 Amp Negative Logic, 32-Point Output Module

Recommended Field Wiring Procedures

The following procedures are recommended when connecting field wiring to the detachable terminal

board on this input module. Module features referenced in the following procedures which are common to all IC697 I/O modules are illustrated in the following figure.

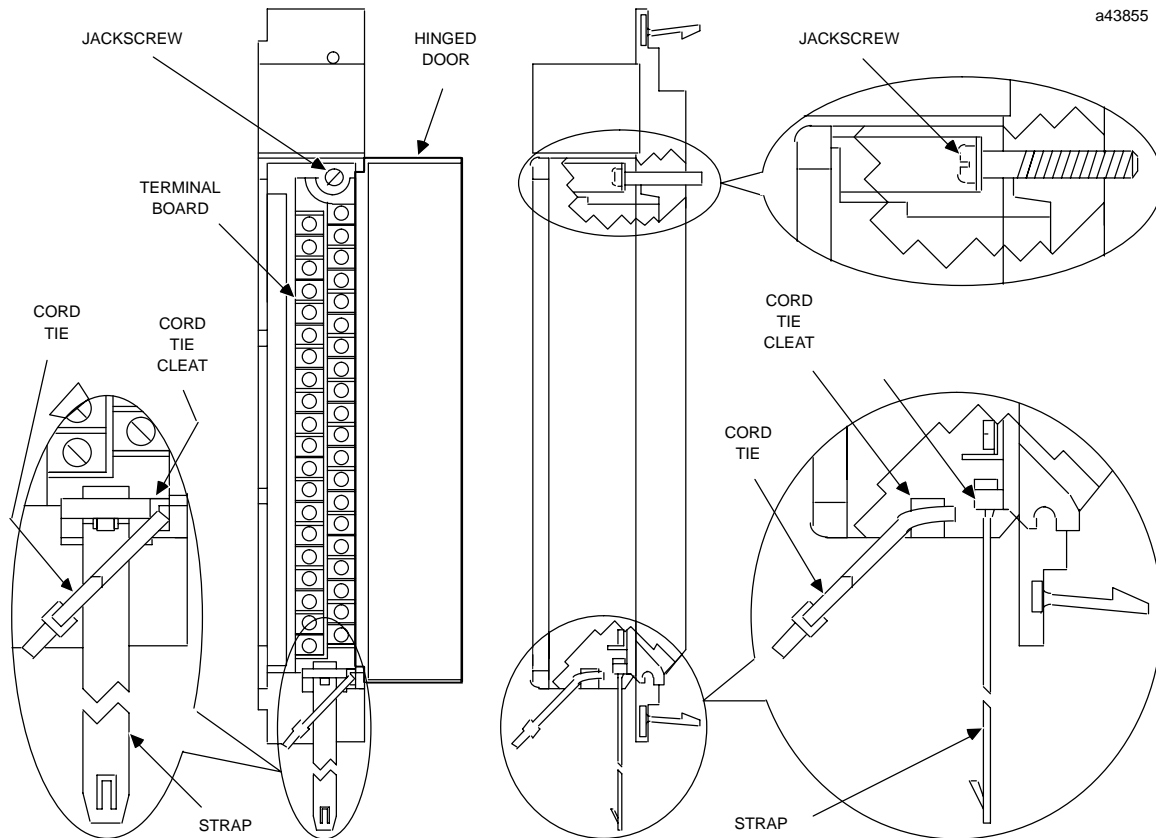

Figure 3. I/O Module Features

1. Turn off power before removing or installing terminal boards. Open the hinged door on the module to access a jackscrew which holds the terminal board securely in place. The detachable field wiring terminal board can now be removed from the module by turning the jackscrew counter-clockwise until it is fully disengaged.
2. To remove the terminal board, grasp the top of the terminal board and swing it outward as shown in Figure 4.
3. The terminal board is designed to accept wire sizes from AWG #22 (0.36 mm^2) through AWG #14 (2.10 mm^2). It is important that when using AWG #14 (2.10 mm^2) wire for wiring all points, that a maximum insulation diameter of .135 inch (3.43mm) not be exceeded. To ensure proper connection, two wires may be terminated on any one terminal only if both wires are the same size.
4. The terminal board is designed to accept a maximum of (40) AWG #14 (2.10 mm^2) wires. If AWG #14 (2.10 mm^2) wires are to be used, then wire markers should be placed at least 8 inches (203 mm) from termination end to provide sufficient space for the hinged door to close.

Caution

Do not use the hinged door to remove the terminal board. The hinged door could be damaged if this is done.

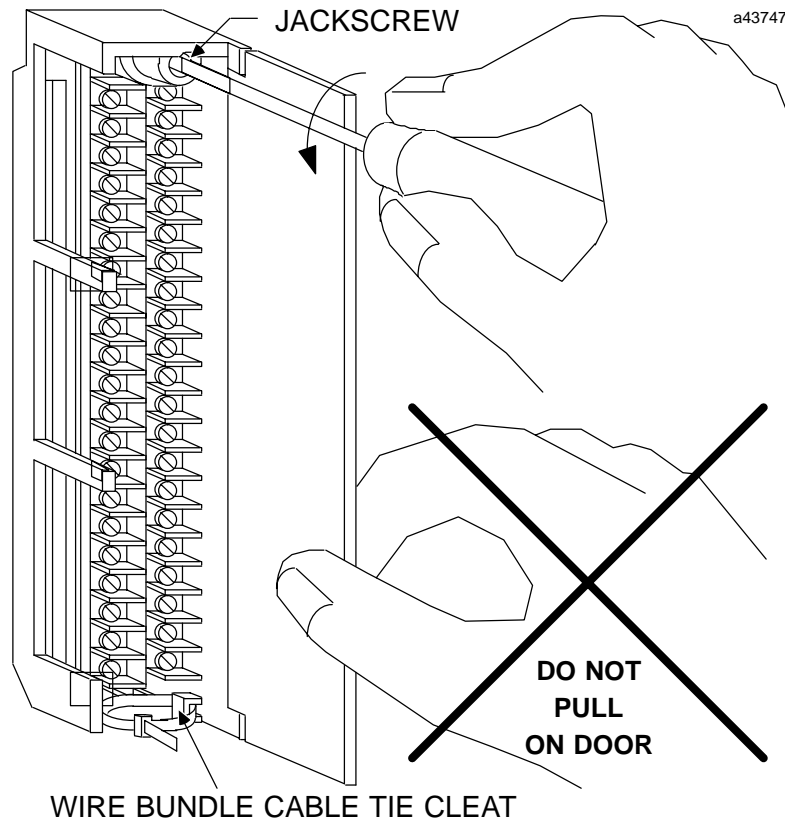

Figure 4. Removal of I/O Terminal Board

5. After completing connections to all modules in a rack, the wire bundle must be secured. To ensure that the wire bundle is secured properly, it is recommended that a cable tie be wrapped around the wire bundle and tightly secured through the cable tie cleat located at the lower right corner of the terminal board. For extremely large wire bundles, additional cable ties should be used.
6. A door label insert is included with each module to indicate circuit wiring information and provide space to record user circuit wiring identification. A slot is provided on the hinged door to allow for insertion of this label. If the label is difficult to insert, crease the scored edge before insertion. The outside label has a color coded stripe to allow quick identification of the module voltage type (blue: low voltage; red: high voltage).
7. After field wiring is completed, the terminal board should be securely fastened to the rack by inserting the terminal board strap (attached to each module) into the small rectangular slots in the bottom card guide grill on the rack. This strap not

only secures the terminal board to the rack, it also provides a way of identifying the wired terminal board with its correct mating rack slot location.

8. For adequate module ventilation, it is recommended that at least a 6 inch (152mm) clearance be allowed above and below the rack grill. Wire bundles should not obstruct the rack grill work.

Removing an I/O Module

The instructions below should be followed when removing an I/O module from its slot in a rack.

- Grasp the board firmly at the top and bottom of the board cover with your thumbs on the front of the cover and your fingers on the plastic clips on the back of the cover.
- Squeeze the rack clips on the back of the cover with your fingers to disengage the clip from the rack rail and pull the board firmly to remove it from the backplane connector.
- Slide the board along the card guide and remove it from the rack.

GFK-0383F
August 1997

5/48 Volt DC 0.5 Amp Negative Logic, 32-Point Output Module

Table 1. Specifications for IC697MDL753

Rated Voltage:	5 volts DC (" 5%) 10 to 60 volts DC
Outputs per Module:	32 (two groups of 16 outputs each)
Isolation:	1500 volts - any output to backplane 500 volts between input groups
Output Voltage Range: Output Current 5 volts DC 10 to 60 volts DC	5 volts or 10 to 60 volts 16 mA maximum per point 0.5 amps maximum per point 4 amps maximum per group
Output Characteristics Inrush Current 10 to 60 volts DC: Output Voltage Drop: 5 volts DC: 10 to 60 volts DC: Response Time-On: Response Time-Off: Output Leakage: 5 volts DC: 10 to 60 volts DC:	 5 amps maximum for 20 ms 0.5 volts maximum (16 mA) 1 volt (2 ohms) maximum 1 ms typical 1 ms typical 250 μ A maximum 1 mA maximum
Current Required from 5 V Bus:	.25 amp
VME	System designed to support the VME standard C.1

† Refer to GFK-0867B, or later for product standards and general specifications.

Table 2. Ordering Information

Description	Catalog Number
Output Module, 5/48 Volt DC 0.5 Amp Negative Logic, 32 Points	IC697MDL753

Note: For Conformal Coat option, or Low Temperature Testing option please consult the factory for price and availability.

Discrete Output Modules

IC697MDL752

GFK-0381E
August 1997

12 Volt DC 0.5 Amp, 32-Point Output Module

Features

- 32 Points - Four isolated groups of 8 points each
- 0.5 amp capacity per point
- High inrush capacity (20x rated current)

Functions

The **12 Volt DC 0.5 Amp Output Module** provides 32 output points in four isolated groups of 8 points each.

The module provides a high degree of inrush current which makes the outputs suitable for a wide range of loads which have such characteristics.

LED indicators which give the ON-OFF status of each point on the logic (PLC) side of the circuit are located together at the top of the module.

The module is mechanically keyed to ensure correct replacement with a similar module type in the field. I/O references are user configurable without the use of jumpers or DIP switches on the module.

Configuration is done using the configuration function of the MS-DOS® or Windows® programming software running on Windows® 95 or Windows NT® over Ethernet TCP/IP or through the SNP port. The Programming Software configuration function is installed on the programming device. The programming device can be an IBM® XT, AT, PS/2® or compatible Personal Computer.

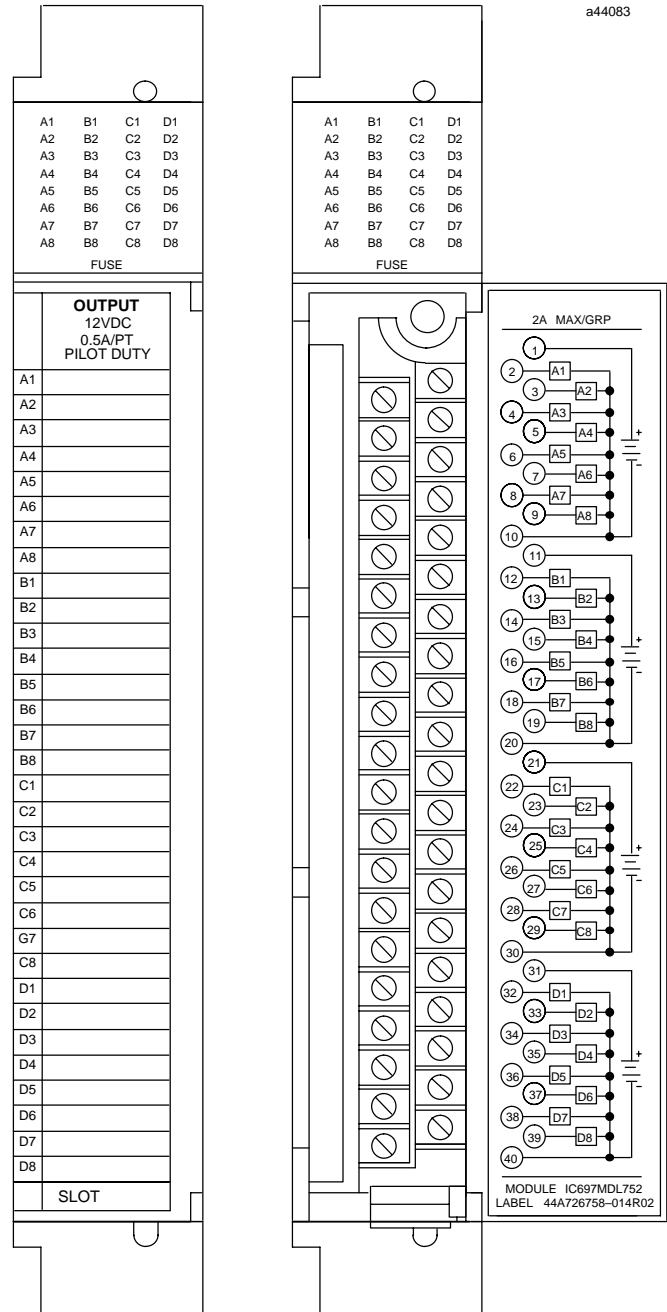

© IBM and PS/2 are registered trademarks of International Business Machines Corporation.

© MS-DOS, Windows, Windows 95, and Windows NT are registered trademarks of Microsoft Corporation.

GFK-0381E
August 1997

12 Volt DC 0.5 Amp, 32-Point Output Module

Operation - 12 Volt DC 0.5 Amp Output Module

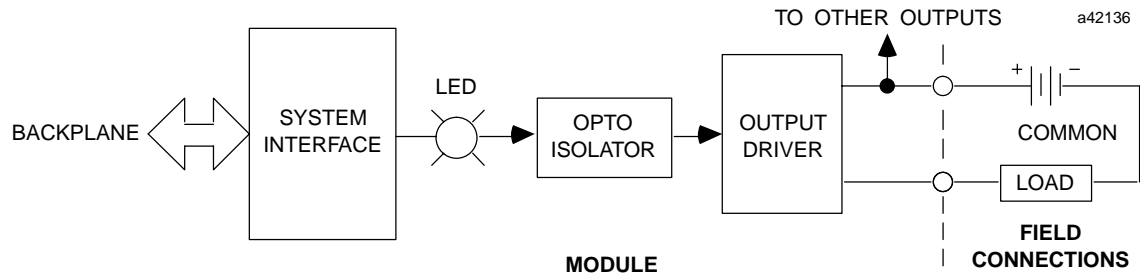

Figure 1. Block Diagram for IC697MDL752

Output Characteristics

The 12 Volt DC 0.5 Amp Output Module is compatible with a wide variety of load devices, such as:

- Solenoids
- Motor starters
- Indicators

The rating of 0.5 amp per point applies to the long-term current capacity of each point. Because of overall heat dissipation within the module, the maximum current for each group of 8 outputs is limited to 2 amperes.

Steady-state Current (mA)	Repetition Rate (Hz)
100	5.0
250	1.0
500	0.1

Each output on this module is capable of transiently conducting a surge current which is much greater than its long-term current rating. The rate at which such surges can be repeated depends on the current

rating of the device and the duty cycle (percent of time the device is ON).

For typical incandescent devices operating at a 50% duty cycle, the following repetition rates apply.

Fault Mode Selection

The module can be configured from the programmer so that output points assume one of two states in response to certain operating or default conditions.

- Maintain existing output state
- Turn outputs OFF

For more detailed information on module configuration, refer to the applicable *Programming Software User's Manual*.

Fusing

The 12 VDC 0.5 Amp Output Module has no fuses. If protection is required, a fuse as specified below may be externally connected to each output point by the user.

- Littlefuse 312.750 (3/4 amp, 250 volt) Fast Acting
- Bussmann AGC-3/4 (3/4 amp, 250 volt) Fast Acting

12 Volt DC 0.5 Amp, 32-Point Output Module

GFK-0381E
August 1997

Module Mechanical Keying

This module includes a mechanical key that prevents inadvertent substitution of one module type for another in a given slot. The key fits a uniquely shaped area on the board below the connector. Each module has a key packaged with it.

When the module is first installed, the key latches onto the backplane center rail. When the module is extracted, the key remains in the center rail, configuring the slot to accept only identical module types.

If it is necessary to change the module location in the rack after the key has been latched onto the center rail of the rack, the key can be removed by pushing it upward to unhook the latch while pulling it off the rail. It may then be reinserted onto the module and the module inserted into the rack in the desired location.

Note that only a power supply can be placed in the leftmost rack position, and slot 1 (adjacent to the power supply) must always contain a CPU (in rack 0 - the CPU rack), or a Bus Receiver Module (in an expansion rack).

Field Wiring

The module is wired as shown in Figure 2. Since each group of eight outputs is isolated from the others, a wire from the power source to the power input terminals for each group is required (power input terminals for each group are not connected inside the module).

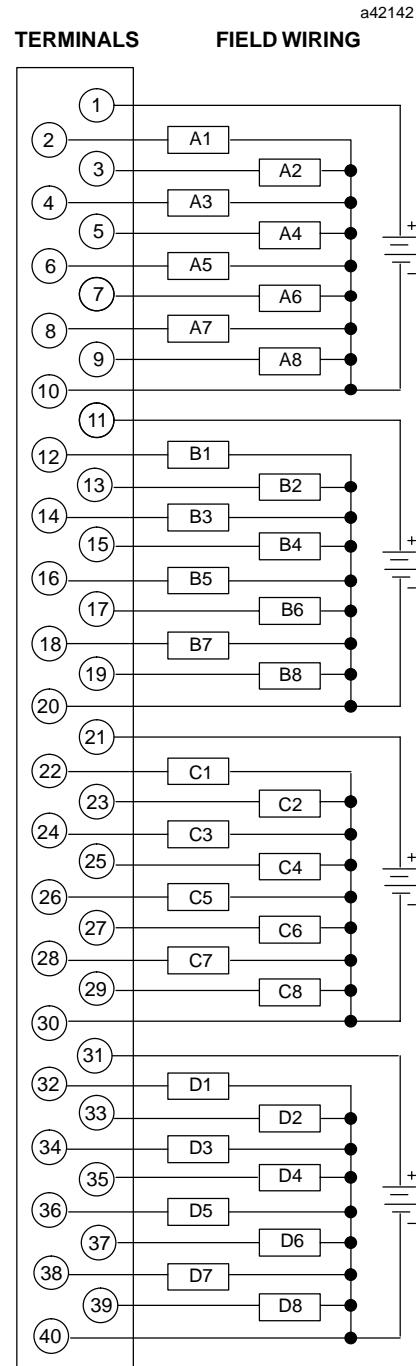

Figure 2. Field Wiring Connections

GFK-0381E
August 1997

12 Volt DC 0.5 Amp, 32-Point Output Module

Recommended Field Wiring Procedures

The following procedures are recommended when connecting field wiring to the detachable terminal board on this input

module. Module features referenced in the following procedures which are common to all IC697 I/O modules are illustrated in the following figure.

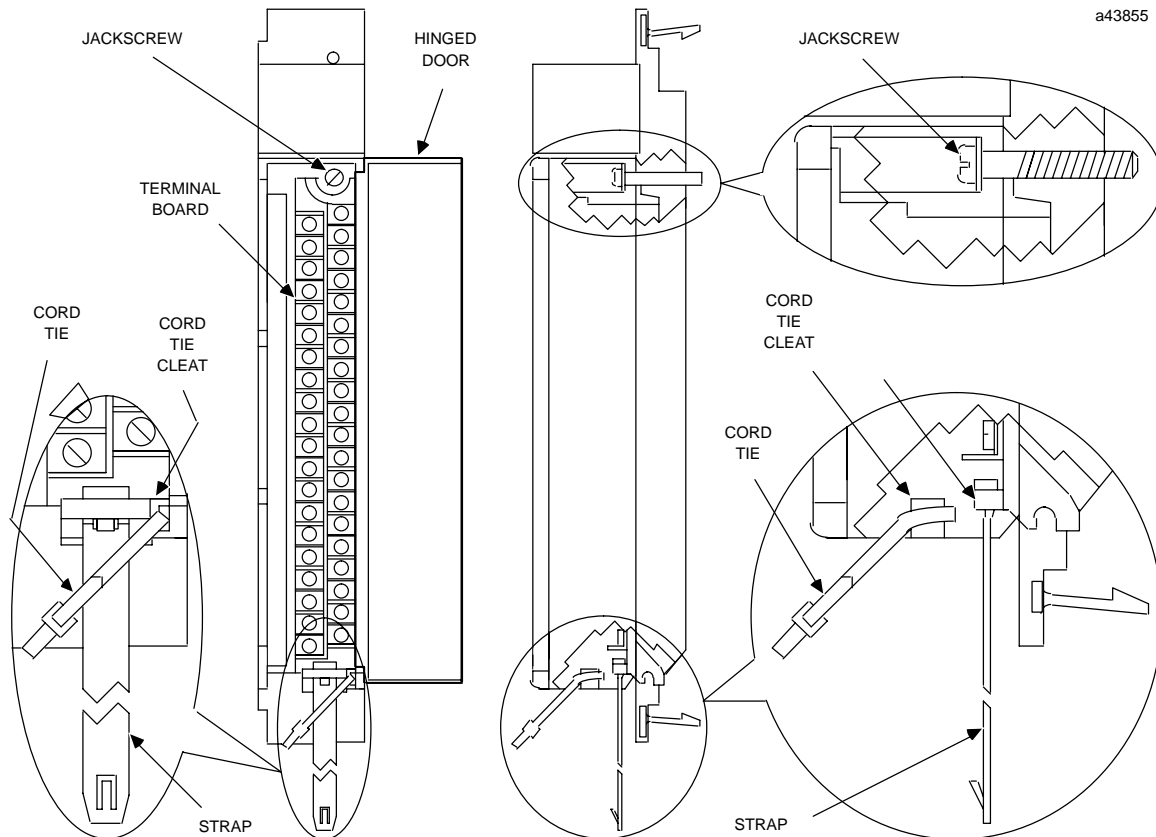

Figure 3. I/O Module Features

1. Turn off power before removing or installing terminal boards. Open the hinged door on the module to access a jackscrew which holds the terminal board securely in place. The detachable field wiring terminal board can now be removed from the module by turning the jackscrew counter-clockwise until it is fully disengaged.
2. To remove the terminal board, grasp the top of the terminal board and swing it outward as shown in Figure 4.
3. The terminal board is designed to accept wire sizes from AWG #22 (0.36 mm^2) through AWG #14 (2.1 mm^2). It is important that when using AWG #14 (2.1 mm^2) wire for wiring all points, that a maximum insulation diameter of .135 inch (3.43mm) not be exceeded. To ensure proper connection, two wires may be terminated on any one terminal only if both wires are the same size.
4. The terminal board is designed to accept a maximum of (40) AWG #14 (2.1 mm^2) wires. If AWG #14 (2.1 mm^2) wires are to be used, then wire markers should be placed at least 8 inches (203 mm) from termination end to provide sufficient space for the hinged door to close.

Caution

Do not use the hinged door to remove the terminal board. The hinged door could be damaged if this is done.

12 Volt DC 0.5 Amp, 32-Point Output Module

GFK-0381E
August 1997

Figure 4. Removal of I/O Terminal Board

5. After completing connections to all modules in a rack, the wire bundle must be secured. To ensure that the wire bundle is secured properly, it is recommended that a cable tie be wrapped around the wire bundle and tightly secured through the cable tie cleat located at the lower right corner of the terminal board. For extremely large wire bundles, additional cable ties should be used.
6. A door label insert is included with each module to indicate circuit wiring information and provide space to record user circuit wiring identification. A slot is provided on the hinged door to allow for insertion of this label. If the label is difficult to insert, crease the scored edge before insertion. The outside label has a color coded stripe to allow quick identification of the module voltage type (blue: low voltage; red: high voltage).
7. After field wiring is completed, the terminal board should be securely fastened to the rack by inserting the terminal board strap (attached to each module) into the small rectangular slots in the bottom card guide grill on the rack. This strap not

only secures the terminal board to the rack, it also provides a way of identifying the wired terminal board with its correct mating rack slot location.

8. For adequate module ventilation, it is recommended that at least a 6 inch (152mm) clearance be allowed above and below the rack grill. Wire bundles should not obstruct the rack grill work.

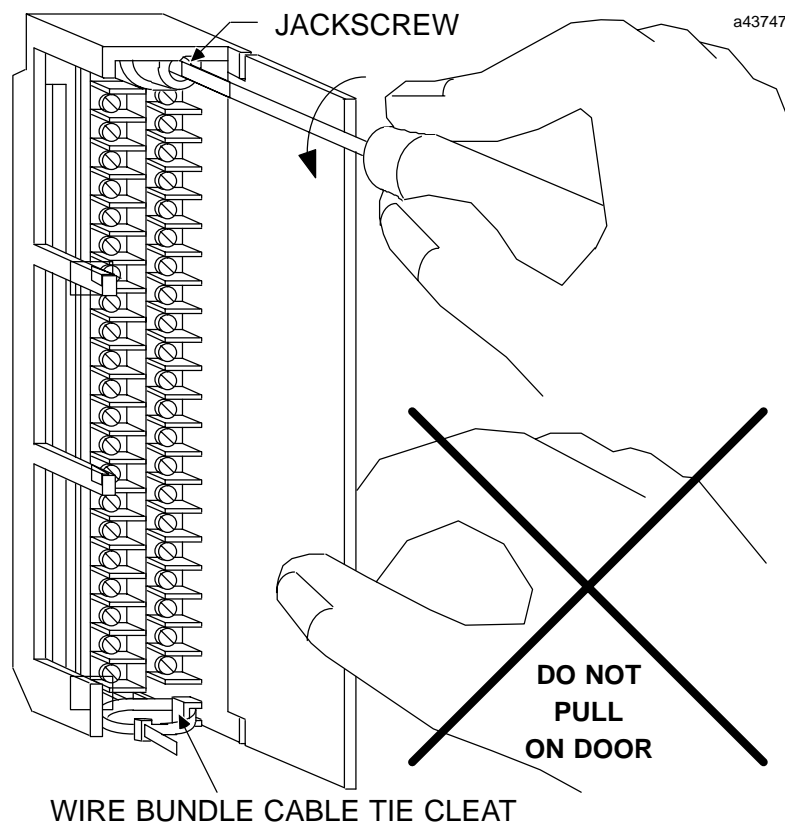
Removing an I/O Module

The instructions below should be followed when removing an I/O module from its slot in a rack.

- Grasp the board firmly at the top and bottom of the board cover with your thumbs on the front of the cover and your fingers on the plastic clips on the back of the cover.
- Squeeze the rack clips on the back of the cover with your fingers to disengage the clip from the rack rail and pull the board firmly to remove it from the backplane connector.
- Slide the board along the card guide and remove it from the rack.

GFK-0381E
August 1997

12 Volt DC 0.5 Amp, 32-Point Output Module

Table 1. Specifications for IC697MDL752 †

Rated Voltage:	12 volts DC
Outputs per Module:	32 (four groups of 8 outputs each)
Isolation:	1500 volts - any output to backplane 500 volts between input groups
Output Voltage Range:	10 to 15 volts
Output Current:	0.5 amps maximum per point 2 amps maximum per group
Output Characteristics	
Inrush Current:	10 amps maximum for 20 ms
Output Voltage Drop:	1 volt (2 ohms) maximum
Response Time-On:	1 ms typical
Response Time-Off:	1 ms typical
Output Leakage:	1 mA maximum
Current Required from 5 V Bus:	.25 amp
VME	System designed to support the VME standard C.1

† Refer to GFK-0867B, or later for product standards and general specifications. For installations requiring compliance to more stringent requirements (for example, FCC or European Union Directives), refer to *Installation Requirements for Conformance to Standards*.

Table 2. Ordering Information

Description	Catalog Number
Output Module, 12 Volt DC 0.5 Amp 32 Points	IC697MDL752

Note: For Conformal Coat option, or Low Temperature Testing option please consult the factory for price and availability.

Discrete Output Modules

IC697MDL750

GFK-0085G
August 1997

24/48 Volt DC, 0.5 Amp, 32-Point Output Module

Features

- 32 Points - Four isolated groups of 8 points each
- 0.5 amp capacity per point
- High inrush capacity (20x rated current)

Functions

The **24/48 Volt DC 0.5 Amp Output Module** for the Programmable Logic Controller (PLC) provides 32 output points in four isolated groups of 8 points each.

This output module provides a high degree of inrush current which makes the outputs suitable for a wide range of loads which have such characteristics.

LED indicators which give the ON-OFF status of each point on the logic (PLC) side of the circuit are located together at the top of the module.

The module is mechanically keyed to ensure correct replacement with a similar type in the field. I/O references are user configurable without the use of jumpers or DIP switches on the module.

Configuration is done using the configuration function of the MS-DOS® or Windows® programming software running on Windows® 95 or Windows NT® over Ethernet TCP/IP or through the SNP port. The Programming Software configuration function is installed on the programming device. The programming device can be an IBM® XT, AT/PS/2® or compatible Personal Computer.

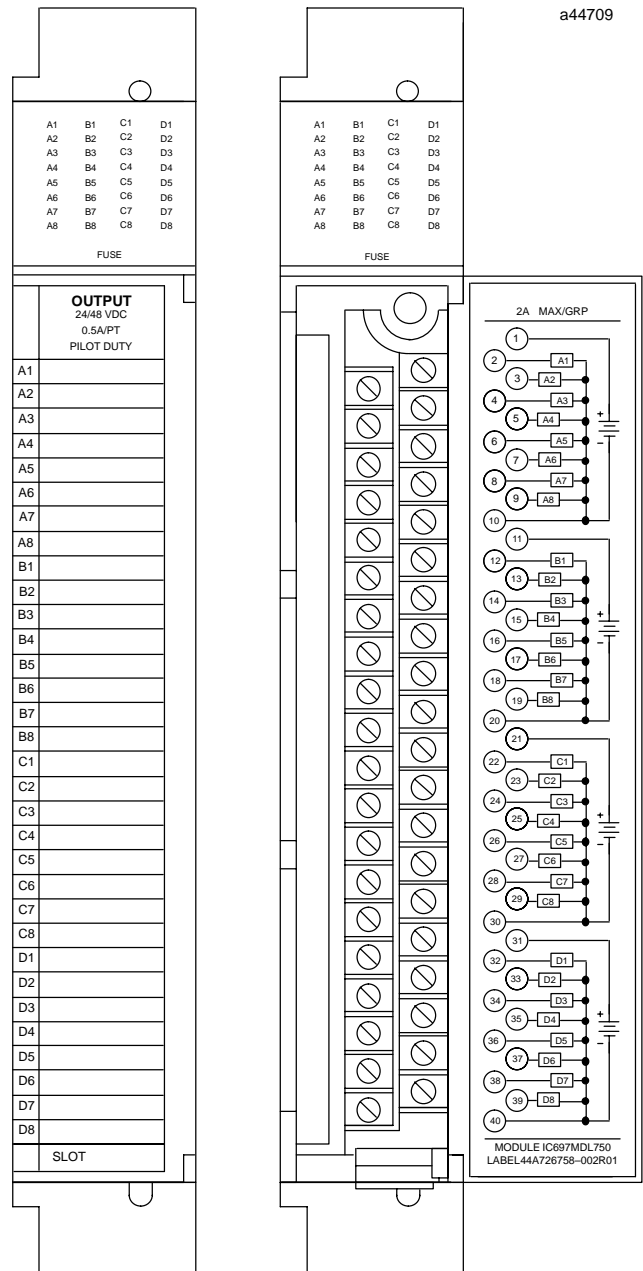

© IBM and PS/2 are registered trademarks of International Business Machines Corporation.

© MS-DOS, Windows, Windows 95, and Windows NT are registered trademarks of Microsoft Corporation.

GFK-0085G
August 1997

24/48 Volt DC, 0.5 Amp, 32-Point Output Module

Operation of the 24/48 Volt DC 0.5 Amp Output Module

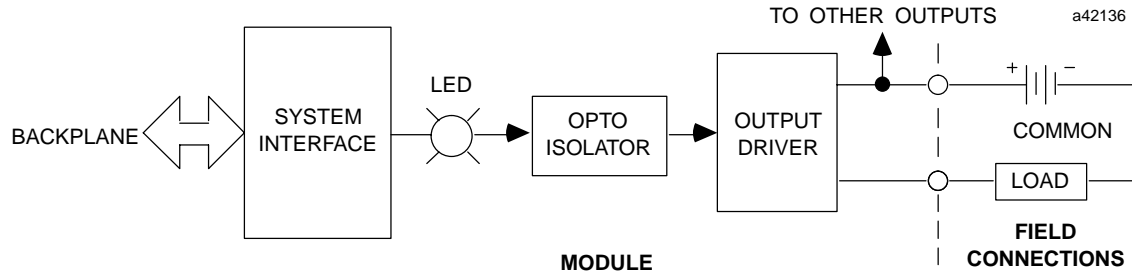

Figure 1. Block Diagram for IC697MDL750

Output Characteristics

The 24/48 Volt DC 0.5 Amp Output Module is compatible with a wide variety of load devices, such as:

- Solenoids
- Motor starters
- Indicators

The rating of 0.5 amp per point applies to the long-term current capacity of each point. Because of overall heat dissipation within the module, the maximum current for each group of 8 outputs is limited to 2 amperes.

Each output on this module is capable of transiently conducting a surge current which is much greater than its long-term current rating. The rate at which such surges can be repeated depends on the current rating of the device and the duty cycle (percent of time the device is ON).

For typical incandescent devices operating at a 50% duty cycle, the following repetition rates apply.

Steady-State Current (mA)	Repetition Rate (Hz)
100	5
250	1
500	0.1

Fault Mode Selection

The module can be configured from the programmer so that output points assume one of two states in response to certain operating or default conditions.

- Maintain existing output state
- Turn outputs OFF

This is explained in more detail in the *Programmable Controllers Reference Manual*.

Fusing

The 24/48 VDC 0.5 Amp Output Module has no fuses. If protection is required, a fuse as specified below may be externally connected to each output point by the user.

- Littlefuse 312.750 (3/4 amp, 250 volt) Fast Acting
- Bussmann AGC-3/4 (3/4 amp, 250 volt) Fast Acting

Module Mechanical Keying

This module includes a mechanical key that prevents inadvertent substitution of one module type for another in a given slot. The key fits a uniquely shaped area on the board below the connector. The key is included with each module.

When the module is first installed, the key latches onto the backplane center rail. When the module is extracted, the key remains in the center rail, configuring the slot to accept only identical module types.

If it is necessary to change the module location in the rack after the key has been latched onto the center rail of the rack, the key can be removed by pushing it upward to unhook the latch while pulling it off the rail. It may then be reinserted onto the module and the module inserted into the rack in the desired location. Note: Only the power supply can be placed in the leftmost rack position.

Field Wiring

The module is wired as shown in Figure 2. Since each group of eight outputs is isolated from the others, a wire from the power source to the power input terminals for each group is required (power input terminals for each group are not connected inside the module).

The detachable field wiring terminal board will accept wire sizes from #22 (0.36 mm²) through #14 (2.10 mm²). Two wires may be terminated on a given lug if both wires are the same size. There is room for a bundle of forty #14 (2.10 mm²) wires to be routed out through the terminal board cavity.

The wire bundle can be secured to the terminal board by passing a cable tie through a cleat located at the lower corner of the terminal board.

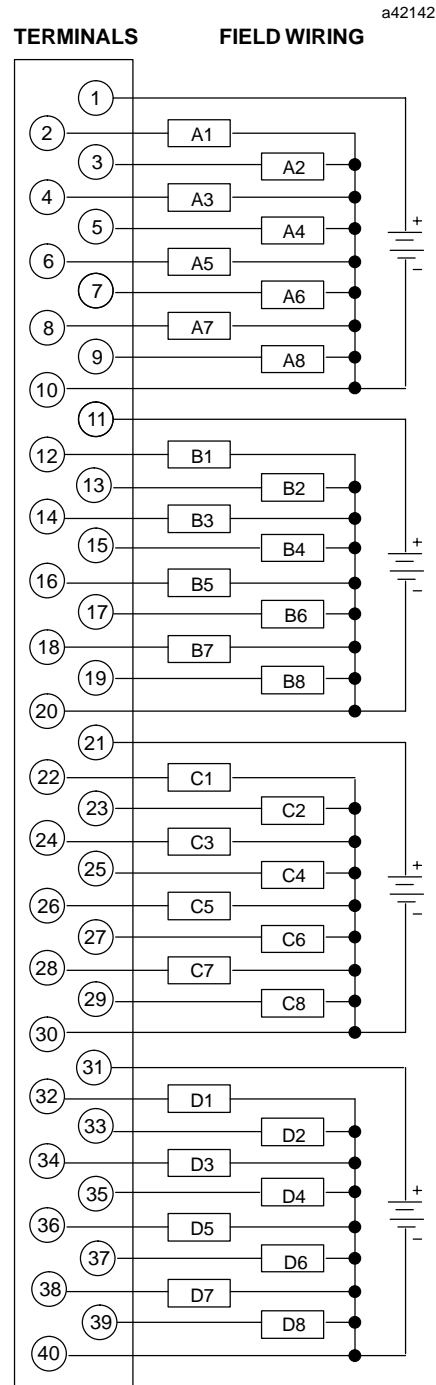

Figure 2. Field Wiring Connections for IC697MDL750

GFK-0085G
August 1997

24/48 Volt DC, 0.5 Amp, 32-Point Output Module

Recommended Field Wiring Procedures

The following procedures are recommended when connecting field wiring to the detachable terminal

board on this input module. Module features referenced in the following procedures which are common to all IC697 I/O modules are illustrated in the following figure.

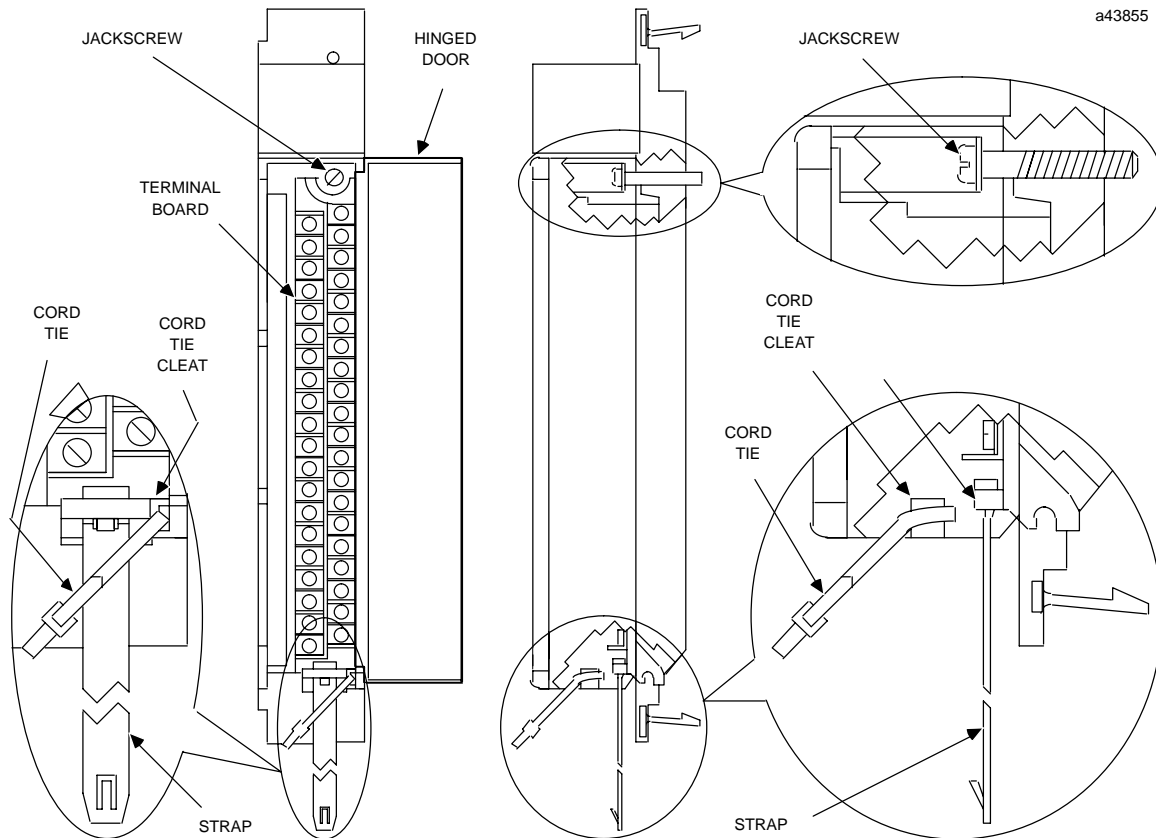

Figure 3. I/O Module Features

1. Turn off power before removing or installing terminal boards. Open the hinged door on the module to access a jackscrew which holds the terminal board securely in place. The detachable field wiring terminal board can now be removed from the module by turning the jackscrew counter-clockwise until it is fully disengaged.
2. To remove the terminal board, grasp the top of the terminal board and swing it outward.
3. The terminal board is designed to accept wire sizes from AWG #22 (0.36 mm^2) through AWG #14 (2.10 mm^2). It is important that when using AWG #14 (2.10 mm^2) wire for wiring all points, that a maximum insulation diameter of .135 inch (3.43mm) not be exceeded. To ensure proper connection, two wires may be terminated on any one terminal only if both wires are the same size.
4. The terminal board is designed to accept a maximum of (40) AWG #14 (2.10 mm^2) wires. If AWG #14 (2.10 mm^2) wires are to be used, then wire markers should be placed at least 8 inches (203 mm) from termination end to provide sufficient space for the hinged door to close.

Caution

Do not use the hinged door to remove the terminal board. The hinged door could be damaged if this is done.

24/48 Volt DC, 0.5 Amp, 32-Point Output Module

GFK-0085G
August 1997

Figure 4. Removal of I/O Terminal Board

5. After completing connections to all modules in a rack, the wire bundle must be secured. To ensure that the wire bundle is secured properly, it is recommended that a cable tie be wrapped around the wire bundle and tightly secured through the cable tie cleat located at the lower right corner of the terminal board. For extremely large wire bundles, additional cable ties should be used.
6. A door label insert is included with each module to indicate circuit wiring information and provide space to record user circuit wiring identification. A slot is provided on the hinged door to allow for insertion of this label. If the label is difficult to insert, crease the scored edge before insertion. The outside label has a color coded stripe to allow quick identification of the module voltage type (blue: low voltage; red: high voltage).
7. After field wiring is completed, the terminal board should be securely fastened to the rack by inserting the terminal board strap (attached to each module) into the small rectangular slots in the bottom card guide grill on the rack. This strap not only secures

the terminal board to the rack, it also provides a way of identifying the wired terminal board with its correct mating rack slot location.

8. For adequate module ventilation, it is recommended that at least a 6 inch (152mm) clearance be allowed above and below the rack grill. Wire bundles should not obstruct the rack grill work.

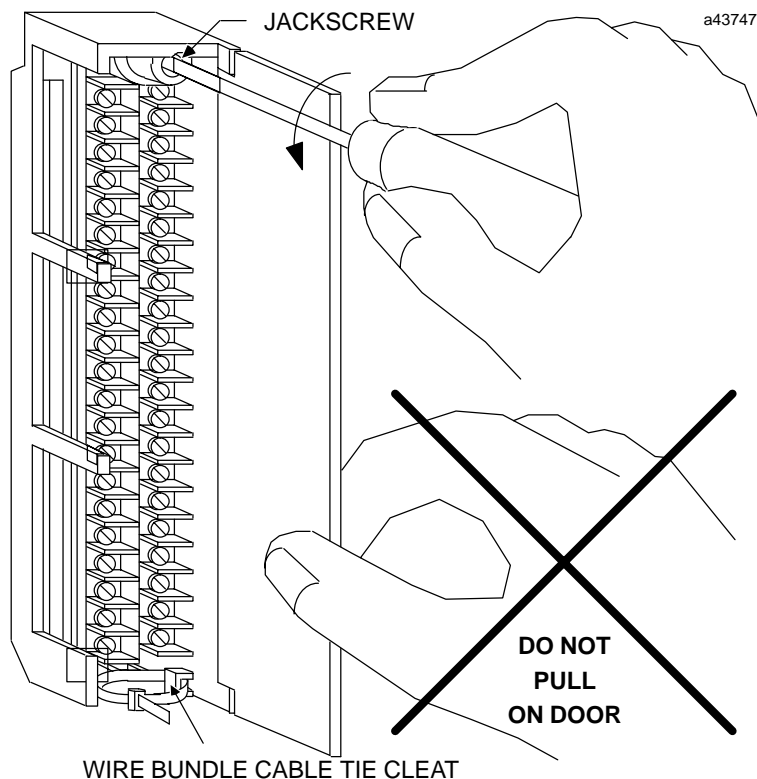
Removing an I/O Module

The instructions below should be followed when removing an I/O module from its slot in a rack.

- Grasp the board firmly at the top and bottom of the board cover with your thumbs on the front of the cover and your fingers on the plastic clips on the back of the cover.
- Squeeze the rack clips on the back of the cover with your fingers to disengage the clip from the rack rail and pull the board firmly to remove it from the backplane connector.
- Slide the board along the card guide and remove it from the rack.

GFK-0085G
August 1997

24/48 Volt DC, 0.5 Amp, 32-Point Output Module

Table 1. Specifications for IC697MDL750 †

Rated Voltage:	24 or 48 volts DC
Outputs per Module:	32 (four groups of 8 outputs each)
Isolation:	1500 volts - any output to backplane 500 volts between input groups
Output Voltage Range:	20 to 60 volts
Output Current:	0.5 amps maximum per point 2 amps maximum per group
Output Characteristics	
Inrush Current:	10 amps maximum for 20 ms
Output Voltage Drop:	1 volt (2 ohms) maximum
Response Time-On:	1 ms maximum
Response Time-Off:	1 ms maximum
Output Leakage:	1 mA maximum
Current Required from 5V Bus:	0.25 amp
VME	System designed to support the VME standard C.1

† Refer to GFK-0867B, or later for product standards and general specifications. For installations requiring compliance to more stringent requirements (for example, FCC or European Union Directives), refer to *Installation Requirements for Conformance to Standards*.

Table 2. Ordering Information

Description	Catalog Number
Output Module, 24/48 VDC 0.5 Amp, 32 points	IC697MDL750

Note: For Conformal Coat option, or Low Temperature Testing option please consult the factory for price and availability.

Discrete Output Modules

IC697MDL740

GFK-0086G
August 1997

24/48 Volt DC, 2 Amp, 16 Point Output Module

Features

- 16 Points - Four isolated groups of 4 points each
- 2 amp capacity per point
- High inrush capacity (10x rated current)

Functions

The **24/48 Volt DC 2 Amp Output Module** provides 16 output points in four isolated groups of 4 points each. Each group of four outputs is individually fused with a 10 amp fuse.

The module provides a high degree of inrush current which makes the outputs suitable for a wide range of loads which have such characteristics.

LED indicators which give the ON-OFF status of each point on the logic (PLC) side of the circuit as well as an LED to indicate the status of the fuse are located together at the top of the module.

The module is mechanically keyed to ensure correct replacement with a similar type in the field. I/O references are user configurable without the use of jumpers or DIP switches on the module.

Configuration is done using the configuration function of the MS-DOS® or Windows® programming software running on Windows® 95 or Windows NT® over Ethernet TCP/IP or through the SNP port. The Programming Software configuration function is installed on the programming device. The programming device can be an IBM® XT, AT/PS/2® or compatible Personal Computer.

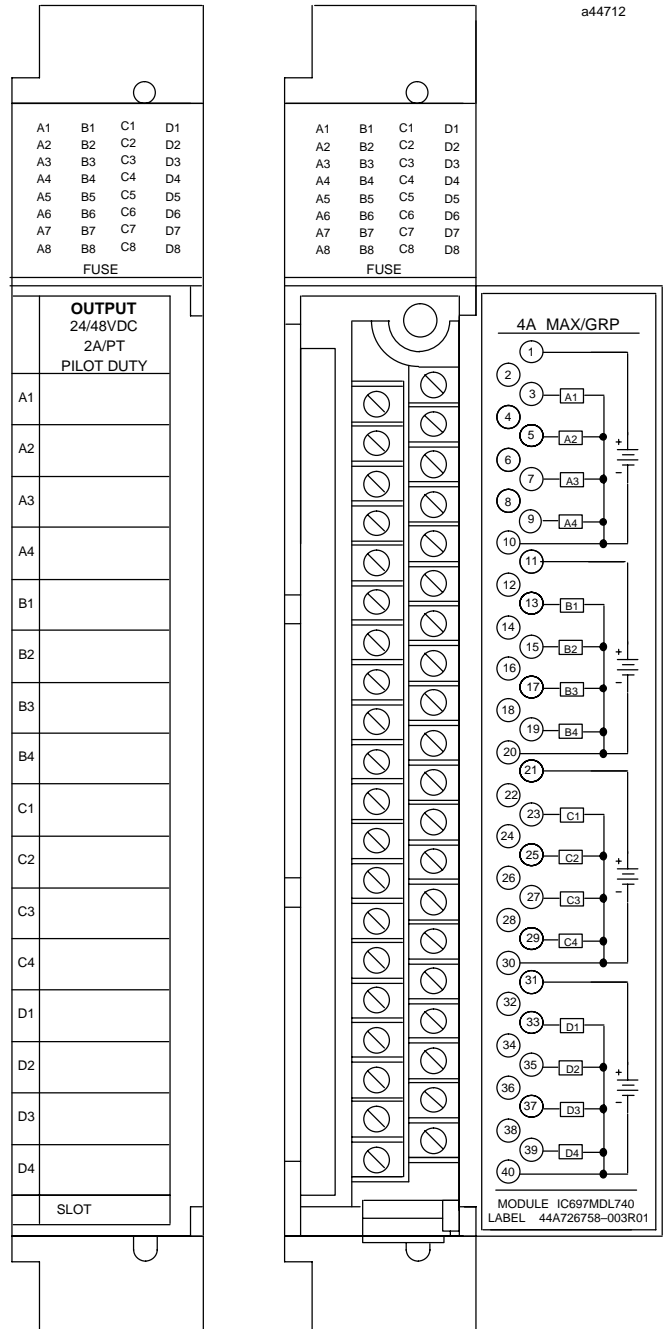

© IBM and PS/2 are registered trademarks of International Business Machines Corporation.

© MS-DOS, Windows, Windows 95, and Windows NT are registered trademarks of Microsoft Corporation.

GFK-0086G
August 1997

24/48 Volt DC, 2 Amp, 16 Point Output Module

Operation of the 24/48 Volt DC 2 AMP Output Module

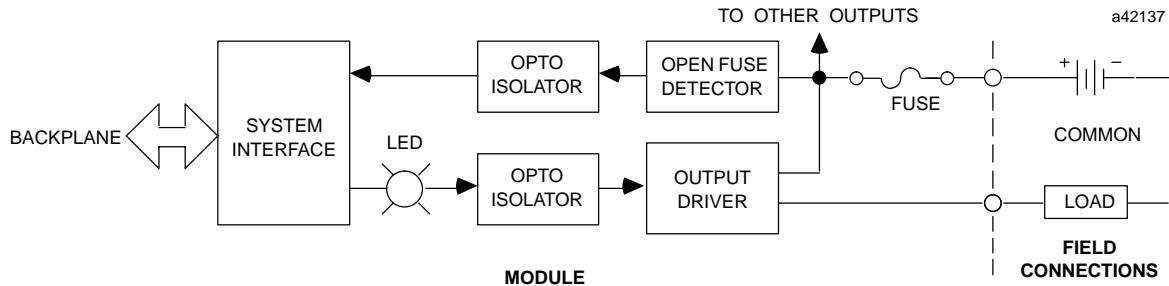

Figure 1. Block Diagram for IC697MDL740

Output Characteristics

The 24/48 Volt DC 2 Amp Output Module is compatible with a wide variety of load devices, such as:

- Solenoids
- Motor starters
- Indicators

The rating of 2 amps per point applies to the long-term current capacity of each point. Because of overall heat dissipation within the module, the maximum current for each group of four outputs is limited to 4 amperes.

Each output on this module is capable of transiently conducting a surge current which is much greater than its long-term current rating. The rate at which such surges can be repeated depends on the current rating of the device and the duty cycle (percent of time the device is ON). For typical incandescent devices operating at a 50% duty cycle, the following repetition rates apply.

Steady-state Current (mA)	Repetition Rate (Hz)
0.5	5
1	1
2	0.1

Fault Mode Selection

The module can be configured from the programmer so that output points assume one of two states in response to certain operating or default conditions.

- Maintain existing output state
- Turn outputs OFF

This is explained in more detail in the programming manual.

Fusing

Each group of 4 outputs is fused with a 10 amp fuse. Replace with either of the following types:

- 3AG - 10 amp, 250V, Fast Acting
- Metric 5 x 20 mm - 10 amp, 250V, Fast Acting

Module Mechanical Keying

This module includes a mechanical key that prevents inadvertent substitution of one module type for another in a given slot. The key fits a uniquely shaped area on the board below the connector. The key is included with each module.

When the module is first installed, the key latches onto the backplane center rail. When the module is extracted, the key remains in the center rail, configuring the slot to accept only identical module types.

If it is necessary to change the module location in the rack after the key has been latched onto the center rail of the rack, the key can be removed by pushing it upward to unhook the latch while pulling it off the rail. It may then be reinserted onto the module and the module inserted into the rack in the desired location. Note: only the power supply can be placed in the left-most rack position.

Field Wiring

The module is wired as shown. Since each group of eight outputs is isolated from the others, a wire from the power source to the power input terminals for each group is required (power input terminals for each group are not connected inside the module).

The detachable field wiring terminal board will accept wire sizes from AWG #22 (0.36 mm²) through AWG #14 (2.1mm²). Two wires may be terminated on a given lug if both wires are the same size. There is room for a bundle of forty #14 wires to be routed out through the terminal board cavity.

The wire bundle can be secured to the terminal board by passing a cable tie through a cleat located at the lower corner of the terminal board.

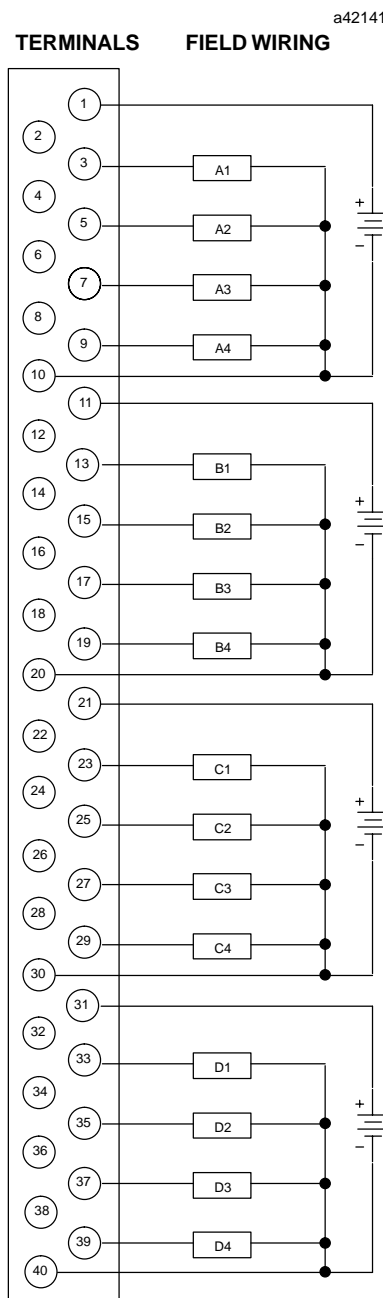

GFK-0086G
August 1997

24/48 Volt DC, 2 Amp, 16 Point Output Module

Recommended Field Wiring Procedures

The following procedures are recommended when connecting field wiring to the detachable terminal board on this input

module. Module features referenced in the following procedures which are common to all IC697 I/O modules are illustrated in the following figure.

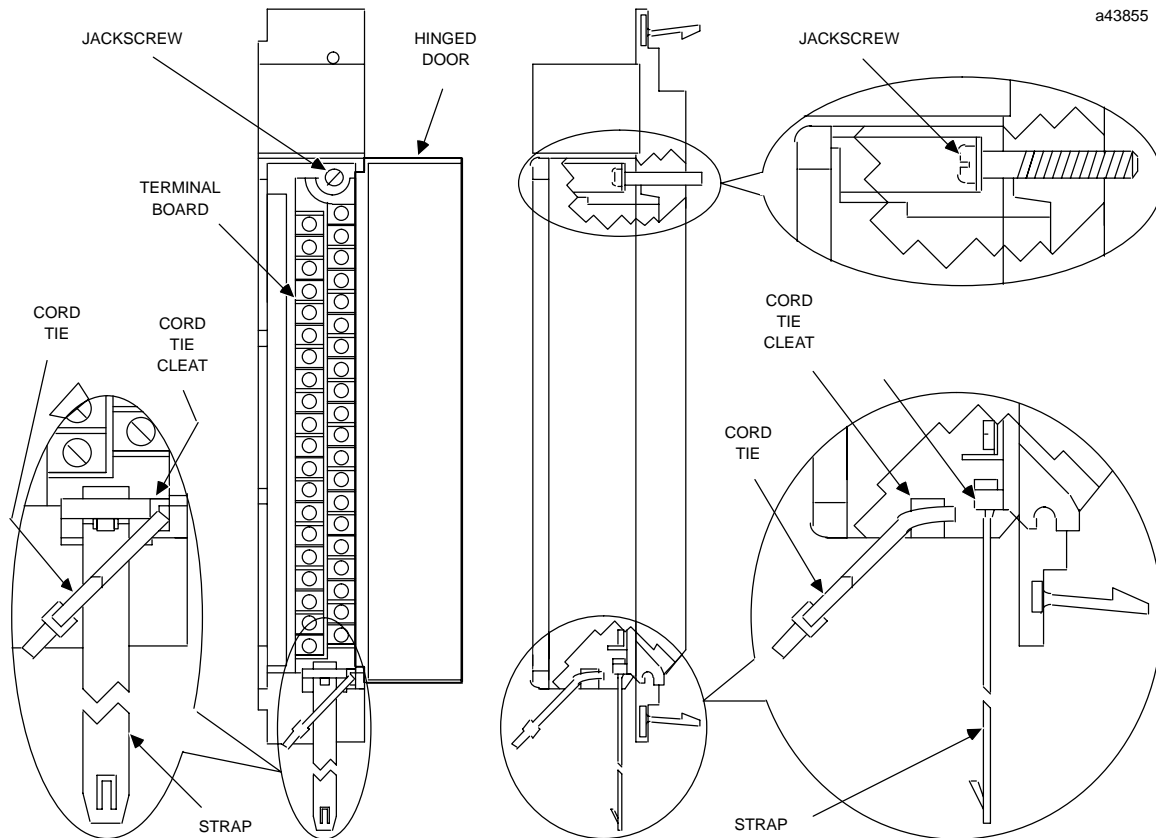

Figure 2. I/O Module Features

1. Turn off power before removing or installing terminal boards. Open the hinged door on the module to access a jackscrew which holds the terminal board securely in place. The detachable field wiring terminal board can now be removed from the module by turning the jackscrew counter-clockwise until it is fully disengaged.
2. To remove the terminal board, grasp the top of the terminal board and swing it outward.
3. The terminal board is designed to accept wire sizes from AWG #22 (0.36 mm²) through AWG #14 (2.1 mm²). It is important that when using AWG #14 (2.1 mm²) wire for wiring all points, that a maximum insulation diameter of .135 inch (3.43mm) not be exceeded. To ensure proper connection, two wires may be terminated on any one terminal only if both wires are the same size.
4. The terminal board is designed to accept a maximum of (40) AWG #14 (2.1 mm²) wires. If AWG #14 (2.1 mm²) wires are to be used, then wire markers should be placed at least 8 inches (203 mm) from termination end to provide sufficient space for the hinged door to close.

Caution

Do not use the hinged door to remove the terminal board. The hinged door could be damaged if this is done.

24/48 Volt DC, 2 Amp, 16 Point Output Module

GFK-0086G
August 1997

Figure 3. Removal of I/O Terminal Board

5. After completing connections to all modules in a rack, the wire bundle must be secured. To ensure that the wire bundle is secured properly, it is recommended that a cable tie be wrapped around the wire bundle and tightly secured through the cable tie cleat located at the lower right corner of the terminal board. For extremely large wire bundles, additional cable ties should be used.
6. A door label insert is included with each module to indicate circuit wiring information and provide space to record user circuit wiring identification. A slot is provided on the hinged door to allow for insertion of this label. If the label is difficult to insert, crease the scored edge before insertion. The outside label has a color coded stripe to allow quick identification of the module voltage type (blue: low voltage; red: high voltage).
7. After field wiring is completed, the terminal board should be securely fastened to the rack by inserting the terminal board strap (attached to each module) into the small rectangular slots in the bottom card guide grill on the rack. This strap not

only secures the terminal board to the rack, it also provides a way of identifying the wired terminal board with its correct mating rack slot location.

8. For adequate module ventilation, it is recommended that at least a 6 inch (152mm) clearance be allowed above and below the rack grill. Wire bundles should not obstruct the rack grill work.

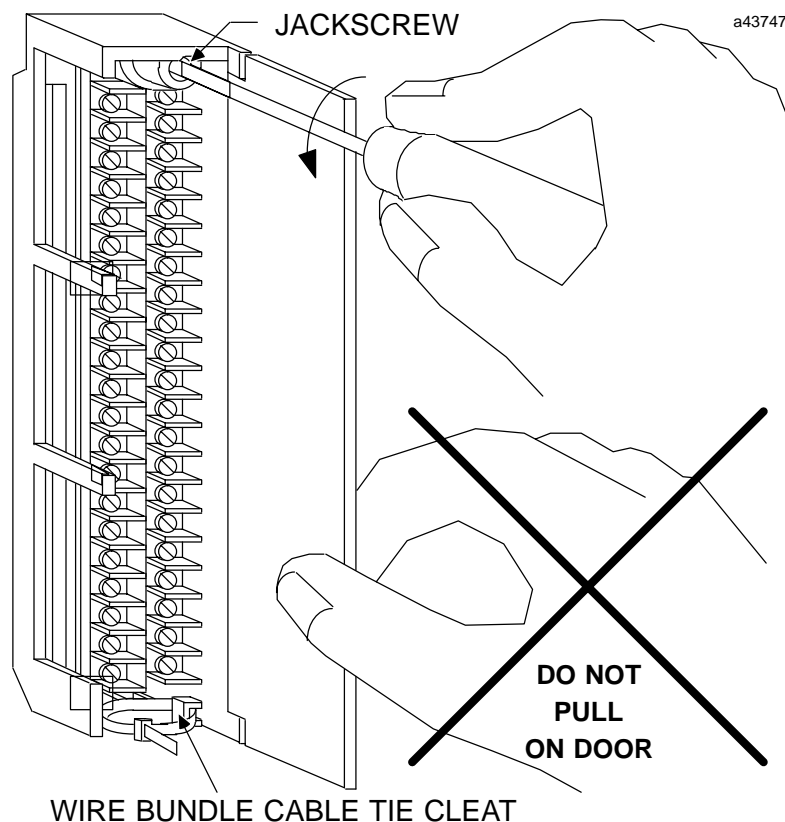
Removing an I/O Module

The instructions below should be followed when removing an I/O module from its slot in a rack.

- Grasp the board firmly at the top and bottom of the board cover with your thumbs on the front of the cover and your fingers on the plastic clips on the back of the cover.
- Squeeze the rack clips on the back of the cover with your fingers to disengage the clip from the rack rail and pull the board firmly to remove it from the backplane connector.
- Slide the board along the card guide and remove it from the rack.

GFK-0086G
August 1997

24/48 Volt DC, 2 Amp, 16 Point Output Module

Table 1. Specifications for IC697MDL740 †

Rated Voltage:	24 or 48 volts DC
Outputs per Module:	16 (four groups of 4 outputs each)
Isolation:	1500 volts - any output to backplane 500 volts between input groups
Output Voltage Range:	20 to 60 volts
Output Current:	2 amps maximum per point 4 amps maximum per group
Output Characteristics -	
Inrush Current:	20 amps maximum for 20 ms
Output Voltage Drop:	0.8 volt (0.4 ohm) maximum
Response Time-On:	2 ms maximum
Response Time-Off:	2 ms maximum
Output Leakage:	1 mA maximum
Current Required from 5V Bus:	0.15 amp
VME	System designed to support the VME standard C.1

† Refer to GFK-0867B, or later for product standards and general specifications. For installations requiring compliance to more stringent requirements (for example, FCC or European Union Directives), refer to *Installation Requirements for Conformance to Standards*.

Table 2. Ordering Information

Description	Catalog Number
Output Module - 24/48 VDC 2 Amp 16 Pt	IC697MDL740

Note: For Conformal Coat option, or Low Temperature Testing option please consult the factory for price and availability.

Discrete Output Modules

IC697MDL940

GFK-0384E
August 1997

Relay Output, 16 Point Module

Features

- 16 points - 8 isolated Form C
- 2 groups of 4 Form A
- 2 amp per point switching capacity
- RC snubber and fuse protection per point
- No user power required
- Removable field wiring terminal

Functions

The 16 point Relay Output Module is **versatile, rugged, and easy to use**. It will switch a variety of low to medium power loads such as relays, contactors, and lamps.

The resistive rating of the module is 2 amps per point at 120/240 VAC or 24 VDC and 0.2 amps per point for 125 VDC. Power to energize the relay coils is supplied by the module and each output is individually fused and suppressed with an RC snubber.

LED indicators which display the ON - OFF status of each point on the logic (PLC) side of the circuit are located at the top of the module.

Field wiring is made to a removable terminal board and the module is mechanically keyed to ensure correct replacement with a similar module type in the field. I/O references are user configurable without the use of jumpers or DIP switches on the module.

Configuration is done using the configuration function of the MS-DOS® or Windows® programming software running on Windows® 95 or Windows NT® over Ethernet TCP/IP or through the SNP port. The Programming Software configuration function is installed on the programming device. The programming device can be an IBM® XT, AT/PS/2® or compatible Personal Computer.

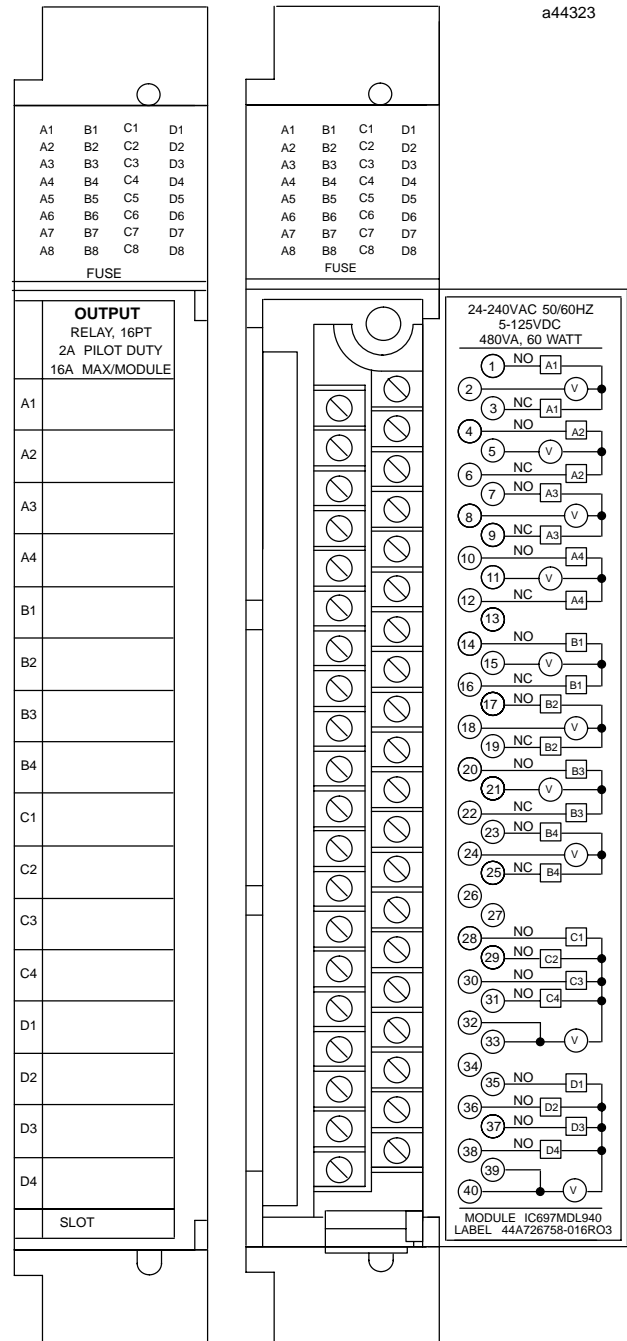

© IBM and PS/2 are registered trademarks of International Business Machines Corporation.

© MS-DOS, Windows, Windows 95, and Windows NT are registered trademarks of Microsoft Corporation.

GFK-0384E
August 1997

Relay Output, 16 Point Module

Operation - Relay Output Module

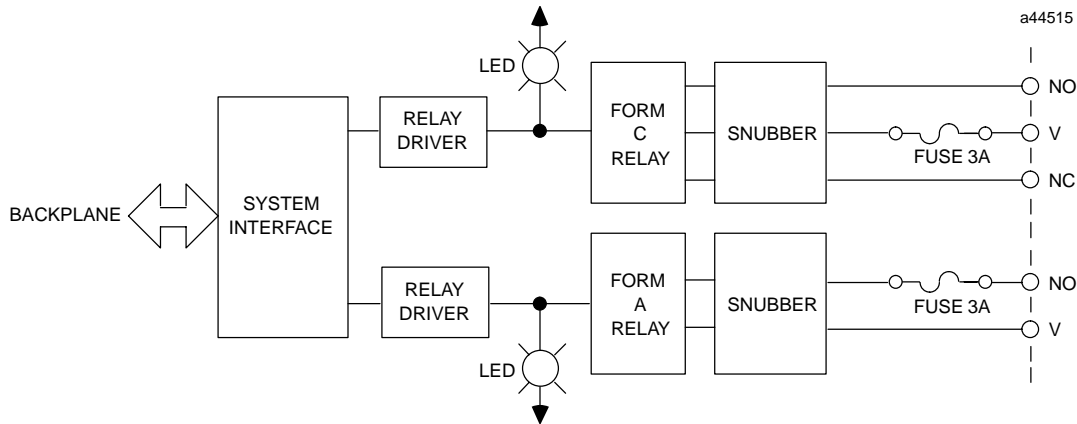

Figure 1. Block Diagram for IC697MDL940

Output Protection

For more detailed information on module configuration, refer to the *Programming Software User's Manual*.

Fusing

Each output is protected with a 3 amp fuse. Replace with either of the following types:

- 3AG - 3.0 amp, 250V, Fast Acting
- Metric 5 x 20 mm - 3.0 amp, 250V, Fast Acting

Suppression

Each output is suppressed with an RC snubber to reduce high frequency noise transients on the board. Proper suppression of the switched load is still recommended and will contribute to improved system reliability. *Suppression at the load will not only lengthen contact life, but will also reduce noise transients in the control wiring.*

Fault Mode Selection

This output module can be configured from the programmer so that output points assume one of two states in response to certain operating or default conditions. These states are:

- Maintain existing output state
- Turn outputs OFF

Module Mechanical Keying

This module includes a mechanical key that prevents inadvertent substitution of one module type for another in a given slot. The key fits a uniquely shaped area on the board below the connector. Each module has a key packaged with it.

When the module is first installed, the key latches onto the backplane center rail. When the module is extracted, the key remains in the center rail, configuring the slot to accept only identical module types.

If it is necessary to change the module location in the rack after the key has been latched onto the center rail of the rack, the key can be removed by pushing it upward to unhook the latch while pulling it off the rail. It may then be reinserted onto the module and the module inserted into the rack in the desired location.

Note that only a power supply can be placed in the leftmost rack position, and slot 1 (adjacent to the power supply) must always contain a CPU (in rack 0 - the CPU rack), or a Bus Receiver Module (in an expansion rack).

Relay Output, 16 Point Module

GFK-0384E
August 1997

Field Wiring

The module is wired as shown in Figure 2. You have the choice of selecting either a normally open or a normally closed relay contact (or both) for each of the eight Form C relays, and four normally open contacts for each group of Form A relays. A connection is provided at the V terminal for a power source for the load. Each Form C relay and each group of the Form A relays can switch either an AC or a DC load.

The detachable field wiring terminal board will accept wire sizes from AWG #22 (0.36 mm²) through AWG #14 (2.1mm²). Two wires may be terminated on a given lug if both wires are the same size. There is room for a bundle of forty #14 wires to be routed out through the terminal board cavity.

The wire bundle can be secured to the terminal board by passing a cable tie through a cleat located at the lower corner of the terminal board.

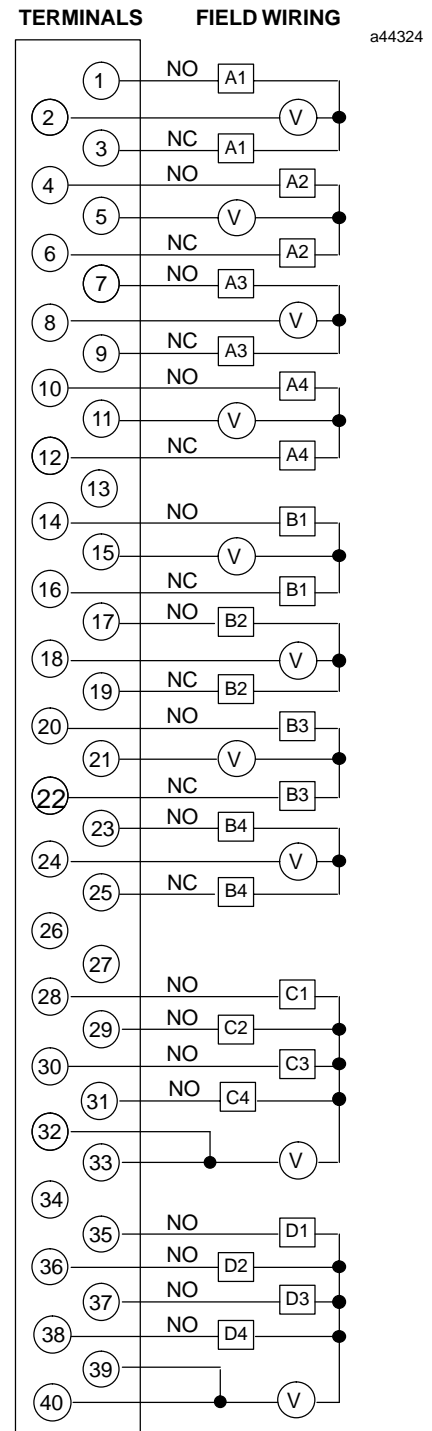

Figure 2. Field Wiring Connections

GFK-0384E
August 1997

Relay Output, 16 Point Module

Recommended Field Wiring Procedures

The following procedures are recommended when connecting field wiring to the detachable terminal

board on this input module. Module features referenced in the following procedures which are common to all IC697 I/O modules are illustrated in the following figure.

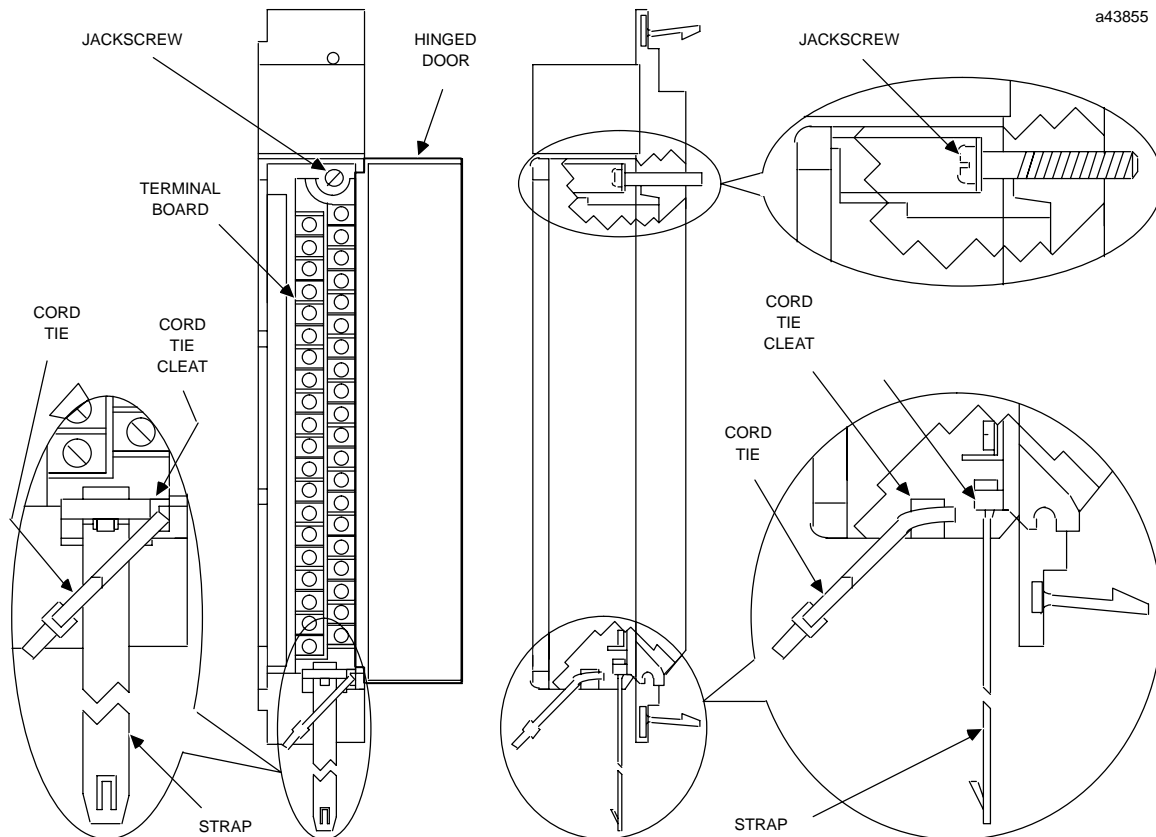

Figure 3. I/O Module Features

1. Turn off power before removing or installing terminal boards. Open the hinged door on the module to access a jackscrew which holds the terminal board securely in place. The detachable field wiring terminal board can now be removed from the module by turning the jackscrew counter-clockwise until it is fully disengaged.
2. To remove the terminal board, grasp the top of the terminal board and swing it outward.
3. The terminal board is designed to accept wire sizes from AWG #22 (0.36 mm) through AWG #14 (2.10 mm). It is important that when using AWG #14 (2.10 mm²) wire for wiring all points, that a maximum insulation diameter of .135 inch (3.43mm) not be exceeded. To ensure proper connection, two wires may be terminated on any one terminal only if both wires are the same size.
4. The terminal board is designed to accept a maximum of (40) AWG #14 (2.10 mm²) wires. If AWG #14 (2.10 mm²) wires are to be used, then wire markers should be placed at least 8 inches (203 mm) from termination end to provide sufficient space for the hinged door to close.

Caution

Do not use the hinged door to remove the terminal board. The hinged door could be damaged if this is done.

Relay Output, 16 Point Module

GFK-0384E
August 1997

Figure 4. Removal of I/O Terminal Board

5. After completing connections to all modules in a rack, the wire bundle must be secured. To ensure that the wire bundle is secured properly, it is recommended that a cable tie be wrapped around the wire bundle and tightly secured through the cable tie cleat located at the lower right corner of the terminal board. For extremely large wire bundles, additional cable ties should be used.
6. A door label insert is included with each module to indicate circuit wiring information and provide space to record user circuit wiring identification. A slot is provided on the hinged door to allow for insertion of this label. If the label is difficult to insert, crease the scored edge before insertion. The outside label has a color coded stripe to allow quick identification of the module voltage type (blue: low voltage; red: high voltage).
7. After field wiring is completed, the terminal board should be securely fastened to the rack by inserting the terminal board strap (attached to each module) into the small rectangular slots in the bottom card guide grill on the rack. This strap not

only secures the terminal board to the rack, it also provides a way of identifying the wired terminal board with its correct mating rack slot location.

8. For adequate module ventilation, it is recommended that at least a 6 inch (152mm) clearance be allowed above and below the rack grill. Wire bundles should not obstruct the rack grill work.

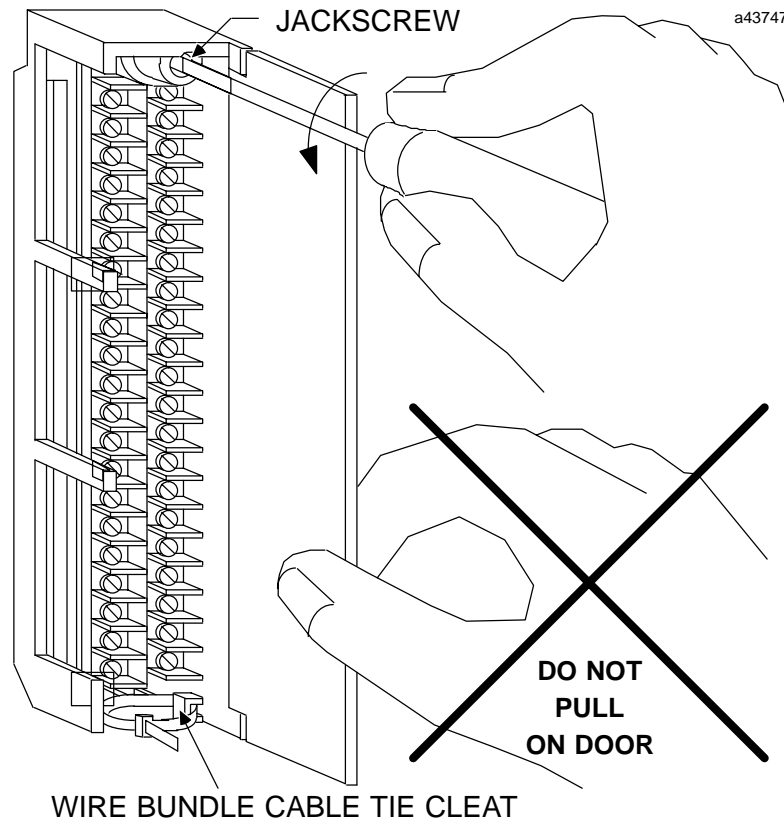
Removing an I/O Module

The instructions below should be followed when removing an I/O module from its slot in a rack.

- Grasp the board firmly at the top and bottom of the board cover with your thumbs on the front of the cover and your fingers on the plastic clips on the back of the cover.
- Squeeze the rack clips on the back of the cover with your fingers to disengage the clip from the rack rail and pull the board firmly to remove it from the backplane connector.
- Slide the board along the card guide and remove it from the rack.

GFK-0384E
August 1997

Relay Output, 16 Point Module

Table 1. Electrical Specifications for IC697MDL940 †

Relay Type:	Fixed coil, moving armature
Outputs per Module:	16
Configuration	8 points - Form C (each point isolated) 8 points - Form A (2 groups with 4 points per group)
Isolation:	1500 volts - any output to backplane 500 volts between Form C circuits or Form A groups
Maximum Load Current (Resistive)	
Per Module	16 amps
Per Group (Form A)	4 amps
Output Switching Characteristics	
Nominal Voltage Rating	120/240 VAC or 5/24/125 VDC
Maximum Power	480 VA (AC loads) or 60 watts (DC loads)
Maximum Load Current (resistive)	2.0 amps from 5 to 265 VAC (maximum), 47-63 Hz 2.0 amps from 5 to 30 VDC (maximum) 0.2 amps from 31 to 125 VDC (maximum) 0.2 amps from 31 to 150 VDC (maximum, Form A only)
Minimum Load Current	10 mA
Maximum Output leakage	1 mA at 120 VAC
Response Time-On:	10 msec (maximum)
Response Time-Off:	10 msec (maximum)
Switching Frequency	20 cycles/minute (inductive load)
Contact Type	Silver alloy
Contact Resistance	0.2 ohm (maximum)
Contact Life	Mechanical: 20 x 10 ⁶ operations Electrical: 10 ⁵ operations at rated resistive load
Protection (each output)	3 amp fuse Snubber (R = 47 ohms, C = 0.015 µfd)
Current Required from 5 V Bus:	750 mA
VME	System designed to support the VME standard C.1

† Refer to GFK-0867B, or later for product standards and general specifications. For installations requiring compliance to more stringent requirements (for example, FCC or European Union Directives), refer to *Installation Requirements for Conformance to Standards*.

Relay Output, 16 Point Module

GFK-0384E
August 1997

Table 2. Typical Contact Life vs. Load Conditions

Operating Voltage	Maximum Current for Load Type		Typical Contact Life (number of operations)
	Resistive	Inductive ^{1,2}	
24 - 120VAC	2.0 amp	1.0 amp	300,000
24 - 120VAC	-	2.0 amp	150,000
24 - 120VAC	1.0 amp	0.5 amp	500,000
24 - 120VAC	0.1 amp	0.05 amp	1,000,000
240VAC	2.0 amp	1.0 amp	150,000
240VAC	-	2.0 amp	50,000
240VAC	1.0 amp	0.5 amp	200,000
240VAC	0.1 amp	0.05 amp	500,000
24VDC	2.0 amp	1.0 amp	300,000
24VDC	-	2.0 amp	100,000
24VDC	1.0 amp	0.5 amp	500,000
24VDC	0.1 amp	0.05 amp	1,000,000

¹ Power Factor = 0.4 minimum for AC inductive loads.² Time Constant = 7ms for DC inductive loads.

Table 3. Ordering Information

Description	Catalog Number
Output Module - Relay, 16 Point	IC697MDL940

Note: For Conformal Coat option, or Low Temperature Testing option please consult the factory for price and availability.

Analog Modules

Base Converter Module - IC697ALG230, Current Expander Module - IC697ALG440
Voltage Expander Module - IC697ALG441

GFK-0385F
August 1997

Analog Input System, High Level, 16 Channels

Features

- Complete Analog subsystem includes Base Converter and Expander modules
- Base Converter module has eight differential inputs individually configurable for voltage or current
- Accepts unipolar or bipolar Analog Inputs up to " 10 volts full scale
- Accepts 4 to 20 milliamp current loop signals
- Individual user scaling on each input channel on Base Converter module; scaling on a per module basis for Expander modules
- Fast update rate for Base Converter module
- Voltage and current Expander modules, each with 16 inputs, provides for additional inputs at a lower cost per point
- Complete subsystem can accept up to 120 inputs
- No jumpers or DIP switches to configure
- Easy configuration with MS-DOS® or Windows® programming software configuration function.

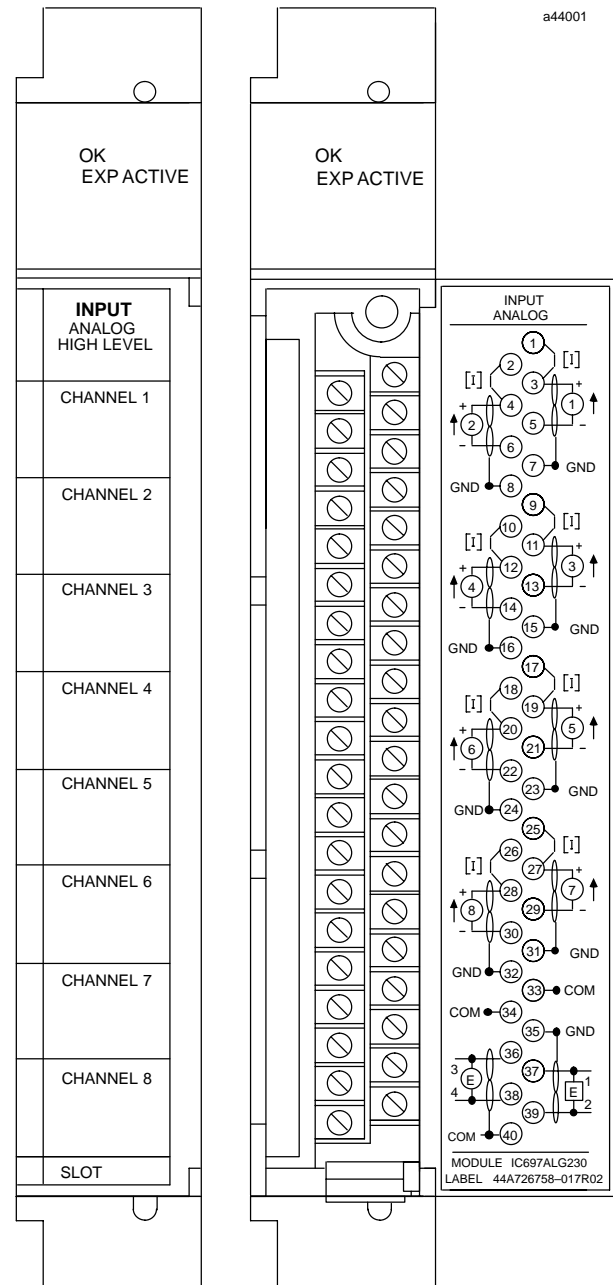

Figure 1. Base Converter Module

© IBM and PS/2 are registered trademarks of International Business Machines Corporation.

© MS-DOS, Windows, Windows 95, and Windows NT are registered trademarks of Microsoft Corporation.

GFK-0385F
August 1997

Analog Input System, High Level, 16 Channels

Functions

The High Level Analog Input subsystem for the Programmable Logic Controller (PLC) accepts analog inputs of up to 10 volts full scale, or 4 to 20 milliamp current loop signals. These inputs are converted to digital form for use by the CPU or other controllers accessing analog inputs via the VME backplane.

Converted data is presented as 2's complement (sign + 15 bits). The basic converter is 14 bits resolution (1 part in 16384); an oversampling and averaging technique further enhances this resolution. Inputs are protected against transient and steady-state overvoltage conditions.

Analog inputs use %AI references in the programmable controller. A maximum of 8K words of %AI memory is currently available in the programmable controller. Each input channel uses one word (16 bits) of %AI memory.

Field wiring is made to a removable terminal board and the module is mechanically keyed to ensure correct replacement with a similar module type in the field. I/O references are user configurable without the use of jumpers or DIP switches on the module.

Configuration is done using the configuration function of the MS-DOS® or Windows® programming software running on Windows® 95 or Windows NT® over Ethernet TCP/IP or through the SNP port. The Programming Software configuration function is installed on the programming device. The programming device can be an IBM® XT, AT/PS/2® or compatible Personal Computer.

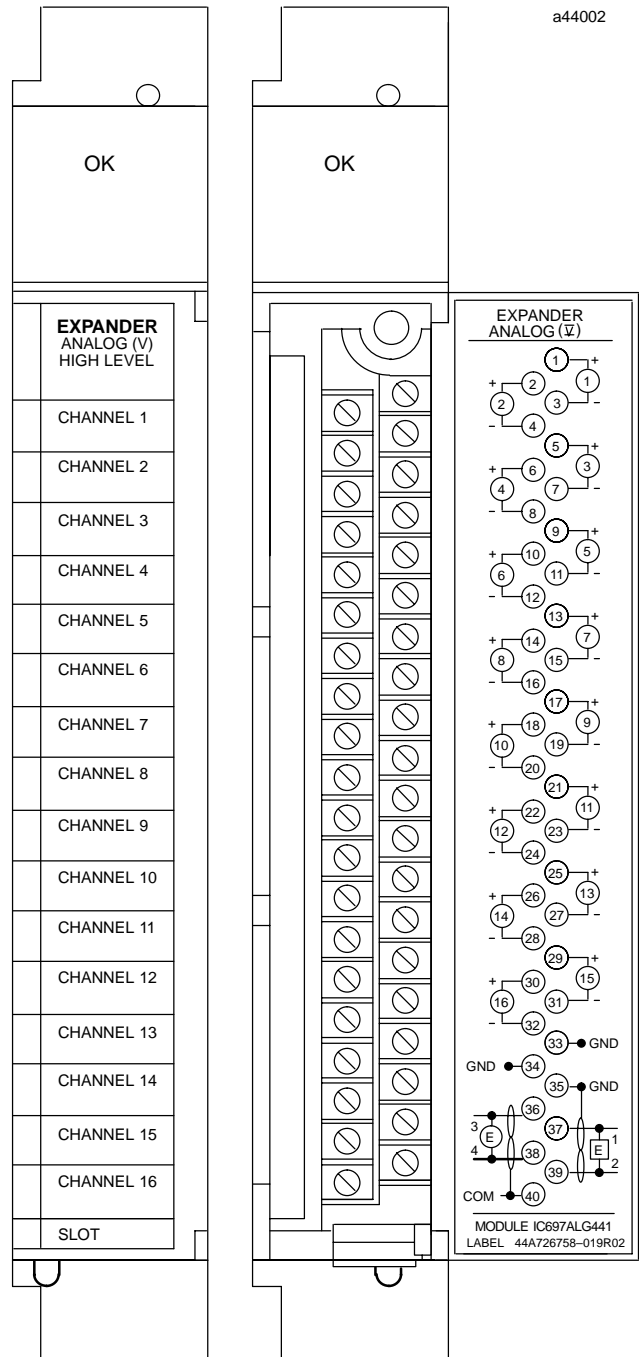

Figure 2. Expander Module

High Level Analog Input System Modules

Three module types are included in the High Level Analog Input subsystem: a Base Converter module, a Current Expander module, and a Voltage Expander module. A typical subsystem will use a Base Converter module and (if required) one or more expander modules.

- **Base Converter module - catalog number IC697ALG230**

This module has eight differential inputs and an expansion port. Each input can be individually configured for either voltage or current. Each of the input channels also has individual user scaling.

On-board load resistors are included for normal input current ranges up to ≈ 40 mA. If other current ranges or different resolution is required, external resistors may be used.

Standard system configurations for ≈ 10 volts and 4 to 20 mA are available. These, and other lower input ranges, can be scaled to engineering units with the user scaling feature.

- **Expander Modules**

Up to seven Expander modules can be daisy-chained off the Base Converter module to increase the number of inputs of the total subsystem up to a maximum of 120.

The Base Converter module accepts any mix of the two Expander module types.

A common user scaling factor applies to all inputs on each Expander module, however each Expander module may be individually scaled as required.

- **Current Input Expander module - catalog number IC697ALG440**

The Current Expander module has 16 current inputs each accepting up to ≈ 20 mA.

- **Voltage Input Expander module - catalog number IC697ALG441**

The Voltage Expander module has 16 differential voltage inputs each accepting up to ≈ 10 V signals.

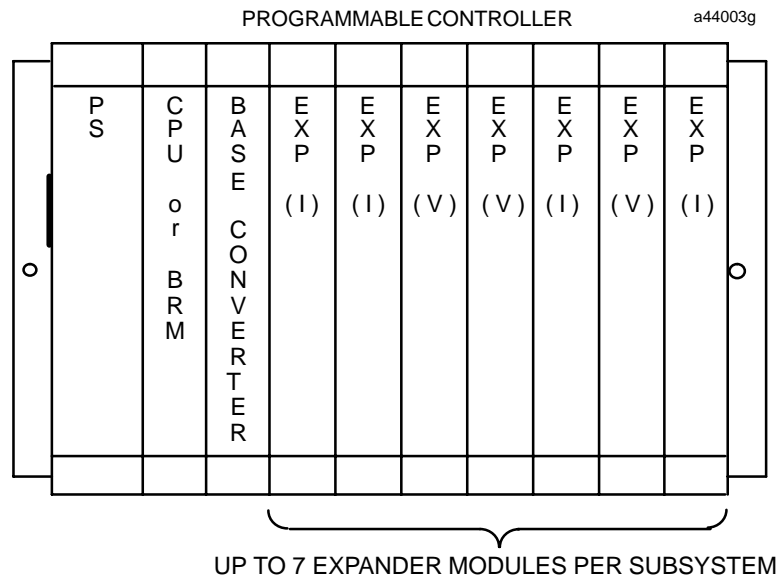

Figure 3. Example of High Level Analog Input System

GFK-0385F
August 1997

Analog Input System, High Level, 16 Channels

System Operation

The following illustration is a block diagram of the High Level Analog Input system followed by an example of typical input connections.

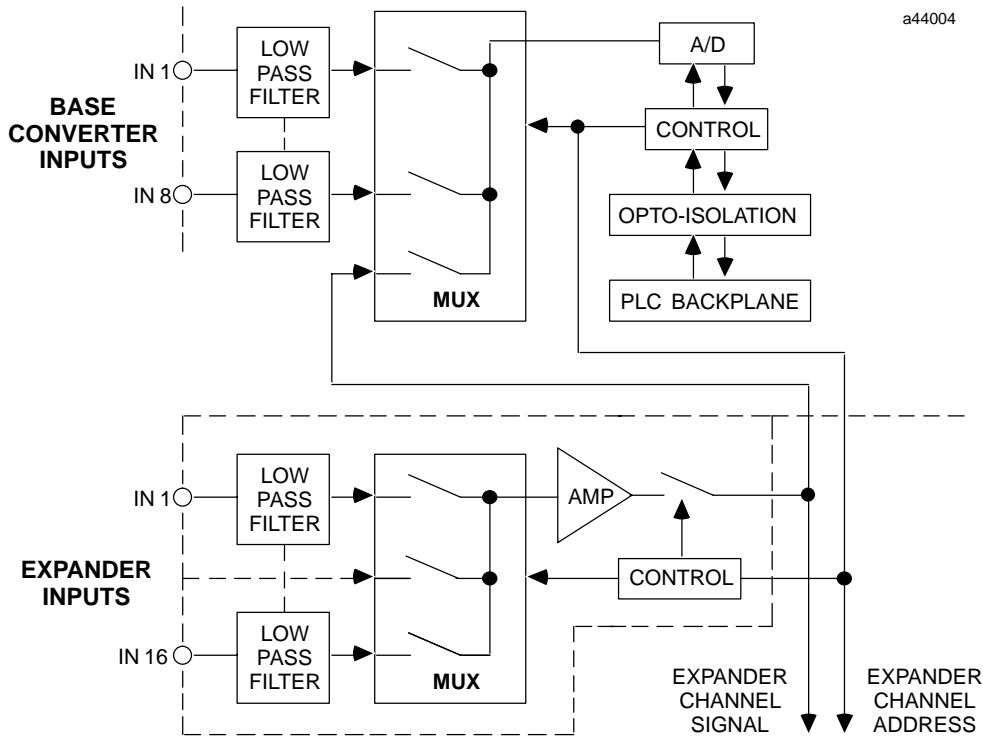

Figure 4. High Level Analog Input System Block Diagram

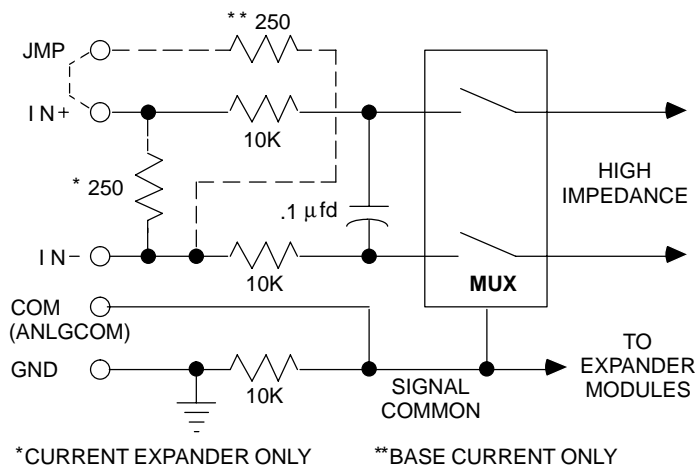
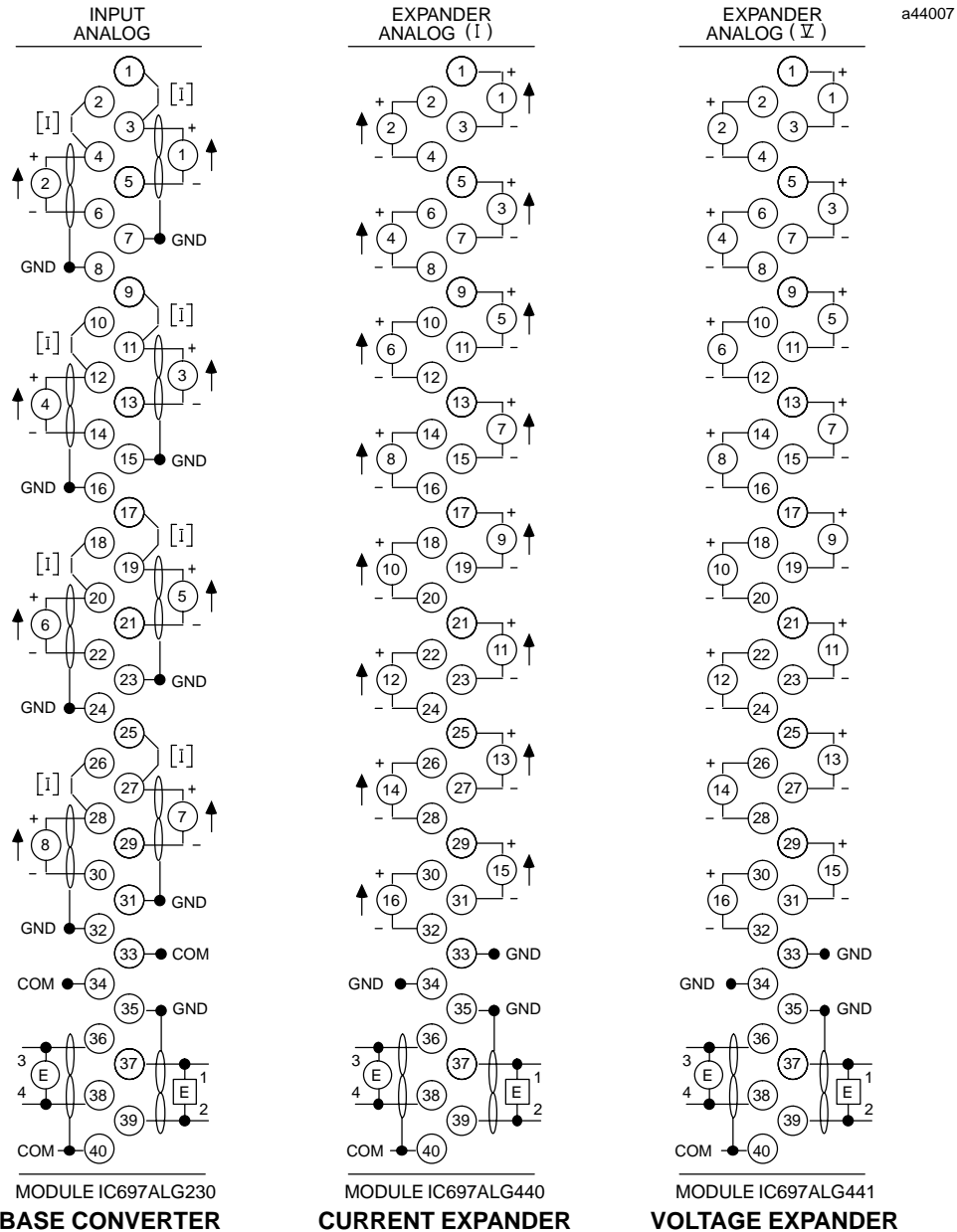

Figure 5. Example of Input Connections

User Wiring Connections

The following illustration shows the wiring assignments for the screw terminals on the terminal board of the Base Converter and Expander modules. In

addition to the information in this data sheet, circuit wiring diagrams are printed on the inside surface of the label inserted in each module's hinged door.



- JUMPER [I] CONNECTS AN INTERNAL 250 OHM LOAD FOR CURRENT INPUTS: LEAVE OFF FOR VOLTAGE INPUTS (BASE CONVERTER ONLY).
- GROUND (GND) IS CHASSIS GROUND.
- COMMON (COM) IS ANALOG COMMON.
- + AND - SHOW POLARITY FOR DIFFERENTIAL INPUTS REFERENCED TO COM.
- PINS 35 THROUGH 40 FORM THE ANALOG EXPANSION BUS.

Figure 6. Field Wiring Connections to I/O Terminal Boards (Base Converter and Expander Modules)

GFK-0385F
August 1997

Analog Input System, High Level, 16 Channels

Recommended Field Wiring Procedures

The following procedures are recommended when connecting field wiring to the detachable terminal

board on an Analog Input Base Converter or Expander module. Module features referenced in the following procedures which are common to all IC697 I/O modules are illustrated in the following figure.

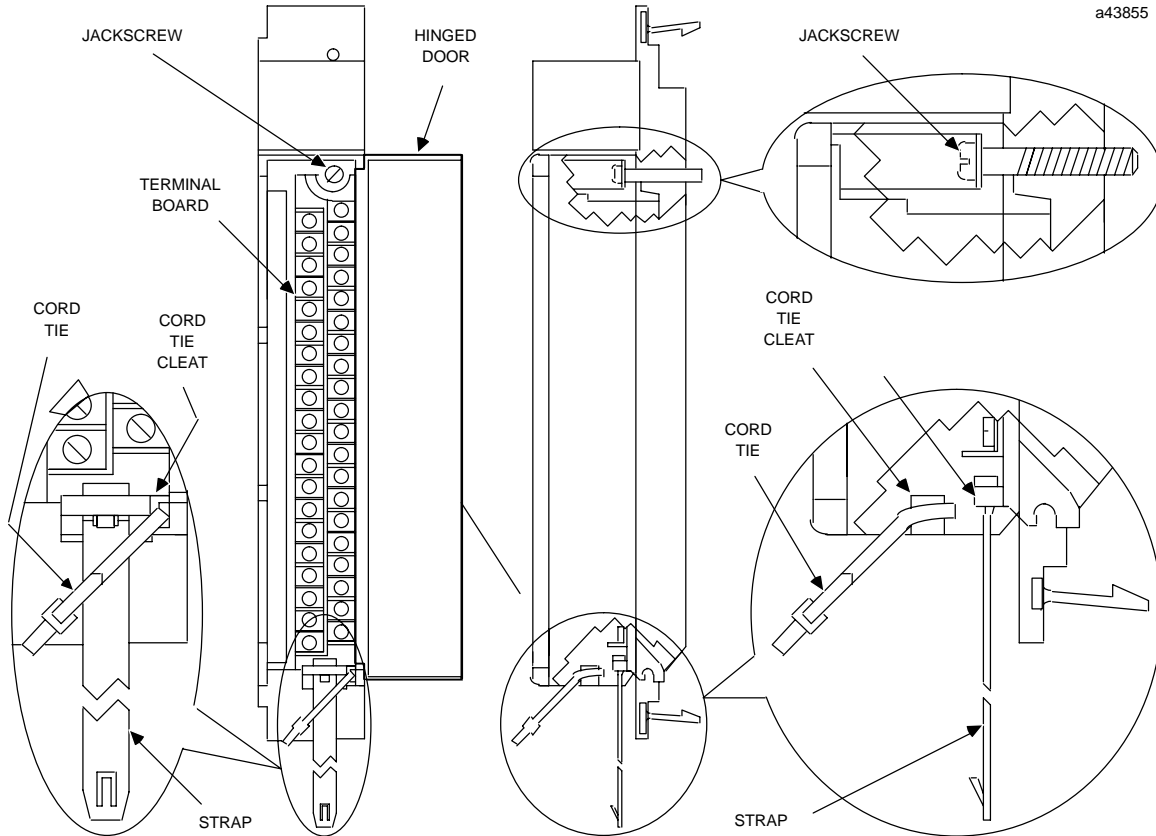

Figure 7. I/O Module Features

1. Turn off power before removing or installing terminal boards. Open the hinged door on the module to access a jackscrew which holds the terminal board securely in place. The detachable field wiring terminal board can now be removed from the module by turning the jackscrew counter-clockwise until it is fully disengaged.
2. To remove the terminal board, grasp the top of the terminal board and swing it outward.
3. The terminal board is designed to accept wire sizes from AWG #22 (0.36 mm) through AWG #14 (2.10 mm). It is important that when using AWG #14 (2.10mm) wire for wiring all points, that a maximum insulation diameter of .135 inch (3.43mm) not be exceeded. To ensure proper connection, two wires may be terminated on any one terminal only if both wires are the same size.
4. The terminal board is designed to accept a maximum of (40) AWG #14 (2.10mm) wires. If AWG #14 (2.10mm) wires are to be used, then wire markers should be placed at least 8 inches (203 mm) from termination end to provide sufficient space for the hinged door to close.

Caution

Do not use the hinged door to remove the terminal board. The hinged door could be damaged if this is done.

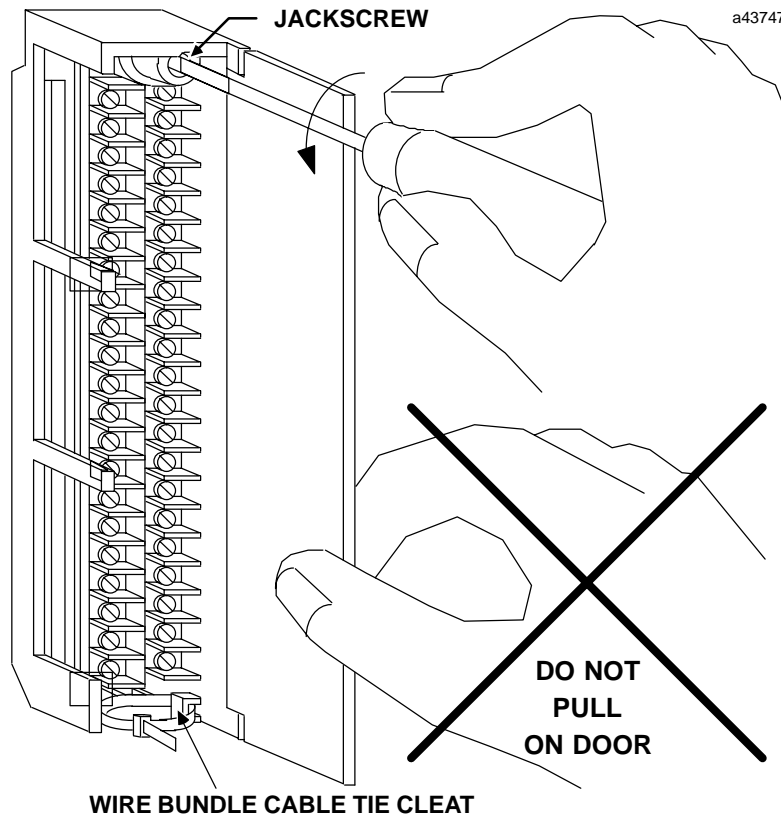

Figure 8. Removal of I/O Terminal Board

5. After completing connections to all modules in a rack, the wire bundle must be secured. To ensure that the wire bundle is secured properly, it is recommended that a cable tie be wrapped around the wire bundle and tightly secured through the cable tie cleat located at the lower right corner of the terminal board. For extremely large wire bundles, additional cable ties should be used.
6. A door label insert is included with each module to indicate circuit wiring information and provide space to record user circuit wiring identification. A slot is provided on the hinged door to allow for insertion of this label. If the label is difficult to insert, crease the scored edge before insertion. The outside label has a color coded stripe to allow quick identification of the module voltage type (blue: low voltage; red: high voltage).
7. After field wiring is completed, the terminal board should be securely fastened to the rack by inserting the terminal board strap (attached to each module) into the small rectangular slots in the bottom card guide grill on the rack. This strap not

only secures the terminal board to the rack, it also provides a way of identifying the wired terminal board with its correct mating rack slot location.

8. For adequate module ventilation, it is recommended that at least a 5 inch (127mm) clearance be allowed above and below the rack grill. Wire bundles should not obstruct the rack grill work.

Removing an I/O Module

The instructions below should be followed when removing an I/O module from its slot in a rack.

- Grasp the board firmly at the top and bottom of the board cover with your thumbs on the front of the cover and your fingers on the plastic clips on the back of the cover.
- Squeeze the rack clips on the back of the cover with your fingers to disengage the clip from the rack rail and pull the board firmly to remove it from the backplane connector.
- Slide the board along the card guide and remove it from the rack.

GFK-0385F
August 1997

Analog Input System, High Level, 16 Channels

Field Wiring Considerations

Connections to Base Converter and Expander modules from user devices are made to screw terminals on the removable 40-terminal connector block mounted on the front of each module. All field connections to the inputs should be wired to the I/O terminal board using a good grade of twisted, shielded instrumentation cable.

The internal resistor for 20 mA current inputs on the Base Converter module is connected by jumpering the upper two terminals on the group for the desired channel, for example, JMP 0 to IN 0+ (refer to Figure 5 for signal names for each group).

Ground connections, (GND), on the terminal board are provided for connecting shields. This ground connection is made directly to the rack, resulting in superior rejection of noise caused by any shield drain currents. Actual selection of ground location may be influenced by system power and ground considerations. However, best operation will be obtained when system ground is physically close to the rack containing the analog circuits. Normally, the shield is grounded at only one end.

For additional system grounding information refer to the discussion on system grounding in chapter 3 of the applicable Programmable Controller Installation Manual.

The module provides electrical isolation of externally generated noise between the input field wiring and the backplane through use of optical isolation.

The best advantage of the superior noise rejection of the differential inputs is obtained by running both input lines to the signal source (as shown in Figure 9), regardless of where ground reference or power supply commons are located.

Inputs are differential. This means the input converted value is the result of the difference between the positive input (+) and the negative input (-), each with respect to COM. Either input can be either polarity with respect to COM. The voltage between the inputs is called *Normal Mode*, while the voltage between inputs and COM is called *Common Mode*. All input signals should have a reference to a system common to ensure that common mode voltages remain within the input range of the module. This is normally a sep-

arate analog common, or if the system is grounded, a separate (from power devices) quiet ground. It could be limited in scope to only the base converter and associated expander COM. The differential configuration reduces errors from DC or low frequency AC supply and ground currents by separating the signal wires from the common which may carry these currents. High frequency and higher voltage spike noise is reduced by filters at the module inputs.

Do not confuse these inputs with *Isolated* type inputs, which have no reference to any common. Sources that have high impedance isolation *must not* be left floating since the high input impedance of the module may allow common mode voltage to drift out of range. This may cause noisy or erroneous data, possibly affecting other channels as well. The differential input allows freedom with respect to location where the signal is referenced to the supply. The differential input can be converted to single ended (referenced to COM), by connecting IN(-) directly to COM at the module terminal. Typical connections for differential inputs are shown in the two figures on the next page.

Current inputs require a connection between JMP and IN+ terminals to connect the internal shunt. This converts the 4 - 20 MA current to a 1 to 5 volt signal. Jumpers are arranged on adjacent terminals to permit use of commercially available jumper strips, which allows for both jumper and wire in the same terminal. Isolated current sources should be referenced to COM by jumpering IN- to COM. Non isolated loops usually should have the return side of the loop supply connected to the analog common. Usually one supply sources several loops, and it is preferable to locate the supply near the analog input. The IN(-) side is returned to COM, either at the module, or wired back to the common side of the loop supply, if the supply is remote.

Field wiring should be shielded wire. Twisted pair, triad (3 wire twisted) or multiple pair cable may be used. Shields are usually grounded at the end nearest where analog signal ground or common is established. Ground at the module if in doubt. Ground terminals are provided for convenience on the module. Variations in data caused by high noise environments are often reduced by additional AC bypass of the shield to ground with a .01 to .1 microfarad capacitor at the ungrounded end.

Analog Input System, High Level, 16 Channels

GFK-0385F
August 1997

In extreme noise environments, the shield can be grounded at both ends, provided the shield is not used to carry any analog signal or analog supply voltages. For noise or surges conducted from sources outside the control enclosure, you should consider terminating the shield at the incoming location of the

enclosure, either using a ground bar or a collar clamp which grounds the shield directly to the metallic enclosure. This gives a much lower ground impedance than possible on the module. The shield is continued up to the module but does not require connection at the module.

Voltage Input Examples

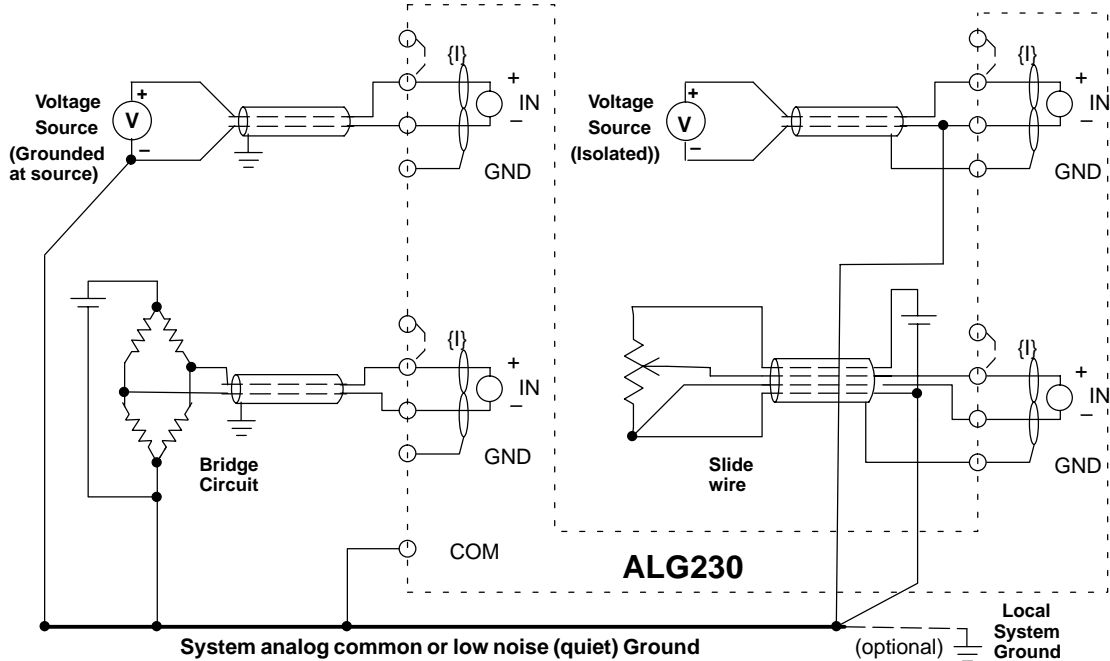

Current Input Examples

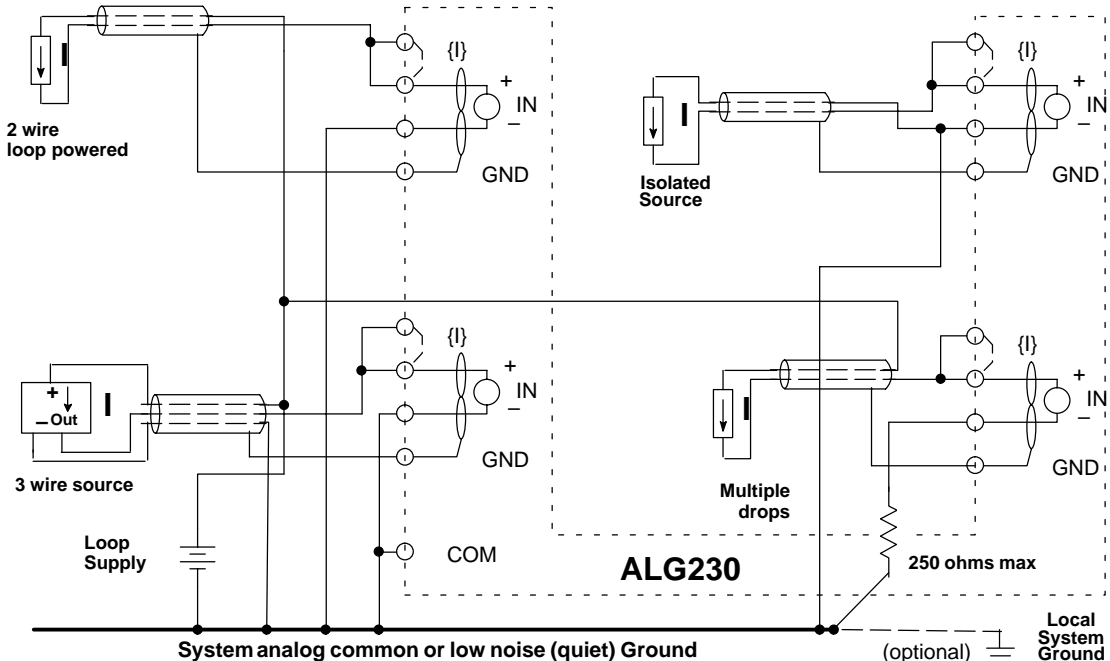

GFK-0385F
August 1997

Analog Input System, High Level, 16 Channels

ANLGCOM is the reference level for all signal inputs. For normal operation when the input signals are referenced to ground, the ANLGCOM terminal may be left open since it is internally connected to ground through an RC circuit as shown in Figure 9. Note that all input signals must be within ± 13 volts of ANLGCOM to obtain specified performances.

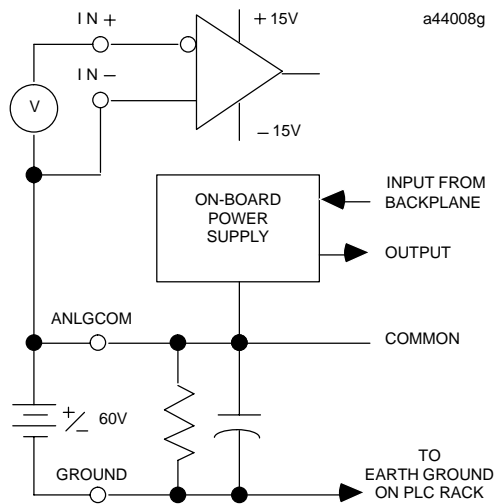

Figure 9. ANLGCOM Connection to Ground

Note

For applications in which the input signals are not referenced to ground, an offset voltage may be introduced between ANLGCOM and GND as shown in Figure 9 to ensure that the input is within the common mode limits of ± 13 volts. Note that all inputs for a single Base Converter/Expander subsystem are referenced to ANLGCOM on the Base unit. The maximum offset voltage for ANLGCOM is ± 60 VDC with respect to earth ground.

If any of the inputs appear to be fluctuating in values, ensure that all terminal pairs are connected to COM or GND.

ExpansionBus

The bottom six terminals (35 through 40) on the terminal board on the Base Converter and Expander modules make up an expansion bus for connecting input Expander modules to the Base Converter module. An analog multiplexer on the Expander module acts as a switching circuit to connect analog inputs, one at a time, to the A/D (Analog to Digital) converter on the Base Converter module.

Input Sampling Techniques

The objective of the input sampling technique for the analog subsystem is to provide 8 input channels on the base module that have a fast (approximately 3 ms) update rate and additional expander channels that are updated less frequently, but have a lower cost per channel.

Operation is such that the base module initially updates all eight channels plus one expander channel. On each successive scan all eight channels of the base converter are again updated - *plus the next expander channel in sequence*. After 16 analog input scans all 16 channels of the first expander have been sampled; on the next scan, all eight base converter channels plus the first channel of the next Expander module are scanned.

This sampling technique continues until all available expander channels (16 x number of Expander modules) have been scanned, at which time the sequence starts over. The number of analog scans required to include sampling of all expander channels is equal to the total number of Expander modules x 16 (16 channels per Expander module) in the system.

With no Expander modules present, each base converter channel is updated once every 2.4 milliseconds. With one or more Expander modules present, this update time increases to 2.8 milliseconds.

Each expander channel is updated every $2.8 \times N$ ms (where N = total number of Expander channels present). Note that the scan sequence is free running and it cannot be synchronized with any external event.

Also note that all inputs of an Expander module will be scanned even if they are not being used.

Table 1. Analog Input Channel Update Times

Number of Expander Modules	Base Channel Update Rate (ms)	Expander Channel Update Rate (ms)
0	2.4	–
1	2.8	45
2	2.8	90
3	2.8	134
4	2.8	179
5	2.8	224
6	2.8	269
7	2.8	314

Connecting the Expander Bus

Terminals 36 and 38 connect the selected analog expansion signal to the Base Converter module. Terminal 40 provides the analog common connection between modules. These terminals should be bussed in parallel with twisted, shielded wire, observing polarity on terminals 36 and 38. The shield must be connected at terminal 40 at both ends of all links between modules in order to connect COM of all boards together. Alternately, a

three-conductor shielded cable can be used, with the third wire making the EXPSHLD connection, and the shield connection to GND.

Terminals 37 and 39 are the expander differential data bus. This is a serial communications port which allows the base converter processor to control the expanders. They must be connected with twisted pair cable, observing polarity. Shielding is optional; if used, connect the shield to GROUND at terminal 35.

NOTE: SHIELDS MUST BE CONNECTED AT EACH END TO TB40

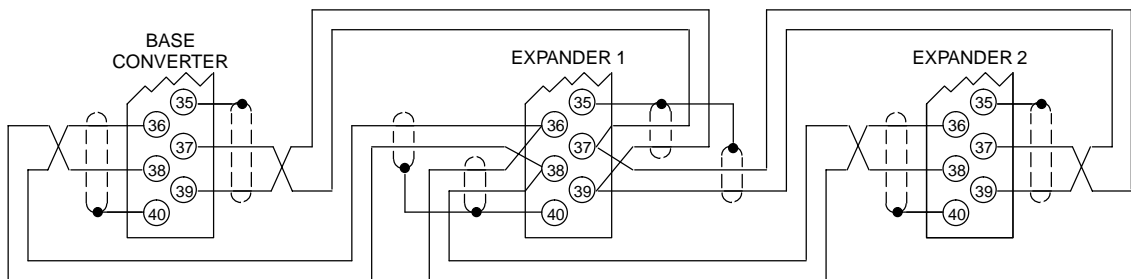

Figure 10. Expander Bus Connections

Module/Rack Configuration

A high level analog input system for the programmable controller can consist of any combination of Base Converter modules and Expander modules up to the I/O module capacity of the rack, or a maximum of 120 inputs for each Base Converter module.

Up to seven Expander modules may be interfaced to a Base Converter module to attain the maximum of 120 inputs (7 Expander modules x 16 inputs = 112 + 8 inputs on Base Converter). **Expander modules must be physically located in the same rack as the Base Converter module, and must be installed in slots to the right of the base converter module. These modules must be adjacent to each other.**

Expander channel numbers are assigned by the system based on the physical location of the Expander module relative to the base converter module. For example, the Expander module in the slot to the immediate right of the base converter module is assigned channels 9 through 24, the next expander is assigned channels 25 through 40, etc., as shown in the following figure.

Expander modules should be located to the immediate right of the controlling Base Converter module, with no empty slots or different module types located between the Base Converter and Expander modules, or between Expander modules.

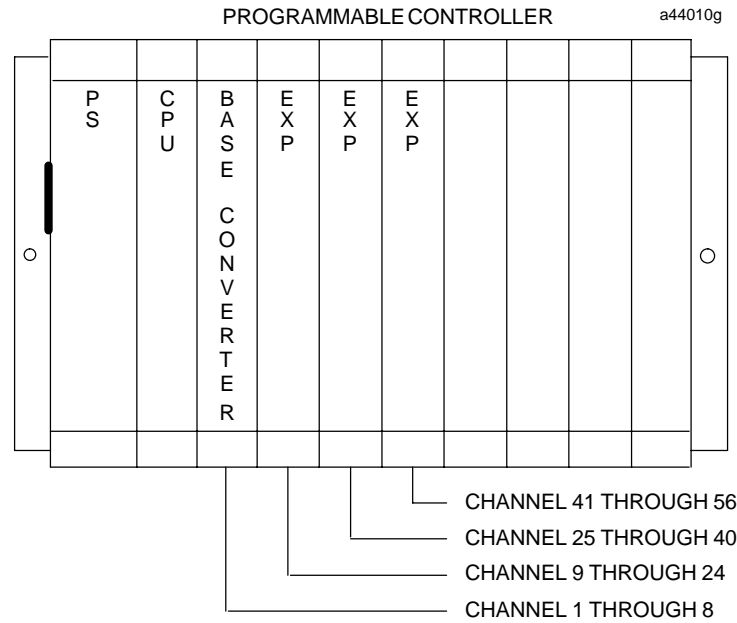

Figure 11. Example of Channel Number Assignments

Module Mechanical Keying

Each module includes a mechanical key that prevents inadvertent substitution of one module type for another in a given slot. The key fits a uniquely shaped area on the board below the connector.

When the module is first installed, the key latches onto the backplane center rail. When the module is extracted, the key remains attached to the center rail, thereby configuring the slot to accept only identical module types.

If it is necessary to change the module location in the rack after the key has been latched onto the center rail of the rack, the key can be removed by pushing it upward to unhook the latch while pushing it off the rail. It may then be reinserted into the rack in the desired location.

Note that in an IC697CHS PLC rack only the power supply can be placed in the leftmost rack position, and slot 1 (adjacent to the power supply) must always contain a CPU (in rack 0 - the CPU rack), or a Bus Receiver Module or Remote I/O Scanner (in expansion racks).

Analog Input System, High Level, 16 Channels

GFK-0385F
August 1997

Configurable Functions

You can configure certain functions through the MS-DOS or Windows software configurator function using the programming device. These functions include input ranges, user scaling, and the alarm comparator function. These functions and their definitions are listed in Table 2.

Module Configuration Data

When power is initially applied to the analog modules the CPU will be updated, through backplane and module software, with the following configuration data:

- Number of main (Base Converter module) input channels used
- Number of Expander modules present and their slot location relative to the Base Converter module

- The type selected (voltage or current) for each Expander module
- The number of channels used for all present Expander modules

After the CPU has been updated with this initial configuration data, the CPU provides the following module configuration data;

- The high and low alarm settings for each main input channel
- The input type (voltage or current) for each main input channel
- CPU alarm interrupt, whether enabled or disabled on a per channel basis (Base Converter module only)
- CPU fault reporting, whether enabled or disabled on a per channel basis for Base Converter module and per board for Expander module

Each of the input channel values is checked for over-range, underrange, and open wire if configured for 4, 20 mA.

Table 2. Configurable Features for the Base Converter Module

Feature	Channel or Module	Selections	Default Setting
<i>Voltage/Current</i>	Channel	-10V, +10V 0, +10 -5V, +5V 0, +5V 4, 20 mA	-10V, +10V
<i>Report Faults</i>	Channel	Enabled/Disabled	Enabled
<i>Scaling Points</i> <i>User Value</i> <i>mV or mA</i>	Channel	" 32767 μ A " 10000 mV	+32000, -32000 μ A +10000 mV, -10000 mV
<i>Report Alarms</i>	Channel	Enabled/Disabled	Disabled
<i>Alarm Values</i> <i>Low</i> <i>High</i>	Channel	" 32767 " 32767	-32767 +32767

GFK-0385F
August 1997

Analog Input System, High Level, 16 Channels

Features of the Voltage Expander module that can be set-up during configuration are listed below.

Table 3. Configurable Features for the Voltage Expander Module

Feature	Channel or Module	Selections	Default Setting
Voltage	Module	-10V, +10V 0, +10 -5V, +5V 0, +5V	-10V, +10V
Report Faults	Module	Enabled/Disabled	Enabled
Scaling Points User Value mV	Module	" 32767 " 32767	+32000, -32000 +10000 mV, -10000 mV

Features of the Current Expander module that can be set-up during configuration are listed below.

Table 4. Configurable Features for the Current Expander Module

Feature	Channel or Module	Selections	Default Setting
Current	Module	4, 20 mA	4, 20 mA
Report Faults	Module	Enabled/Disabled	Enabled
Scaling Points User Value mA	Module	" 32767 " 32767	+32000, 0 +20000 mA, 4000 mA

Note

For detailed information on using the configuration function refer to the *Programming Software User's Manual*.

Input Ranges

The Base Converter input type (voltage or current) can be individually programmed for each input point. The range selected should match the input signal. *Current inputs require the use of the built-in or a user supplied external burden resistor.* The Expander input points are all the same on a module, either voltage or current, determined by the module type.

User Scaling

The scaling feature allows you to define any linear relationship between the sensed input voltage or current and the value in engineering units that is returned to the PLC. The default configuration, as shown in Figure 12, provides values of -32000 to +32000 corresponding to a voltage input range of -10 to +10 volts. If a channel (or Expander module) is configured for current, default scaling is 0 to 32000 for an input current range of 4 to 20 mA (see Figure 13).

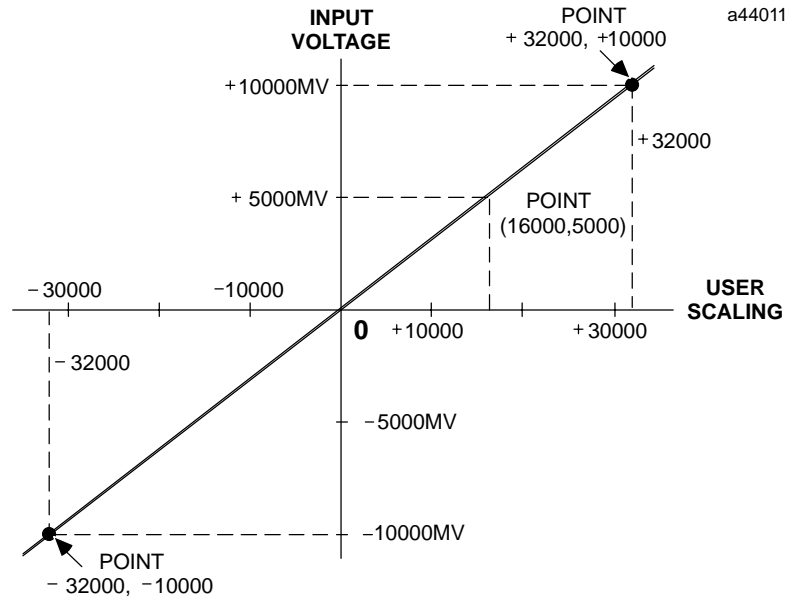

Figure 12. User Scaling for Voltage Input

Scaling can be configured on a per channel basis for the Base Converter module and on a per module basis for Expander modules. Scaling is set by entering the desired voltage or current input value and the corresponding engineering units for each of two points. Engineering units are a 16-bit signed value (-32768 to +32767).

When configuring scale factors, 0 mV or 0 mA must correspond to an engineering units number between +32767 and -32767.

Note

Scaling to engineering units does not increase the resolution of the value, but does transform it into more convenient units. Scaling can be used to compensate for differences between actual and theoretical values due to inaccuracies encountered in field devices.

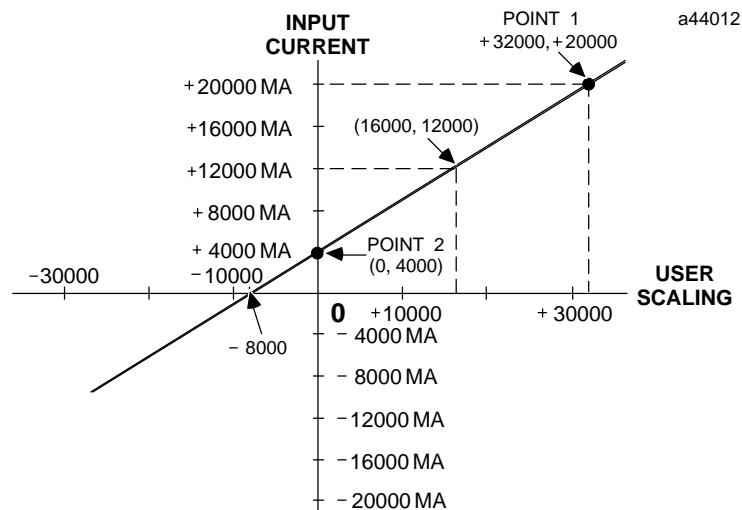

Figure 13. User Scaling for Current Input

GFK-0385F
August 1997

Analog Input System, High Level, 16 Channels

Using Data Commands to Modify Configuration

The Data Command provides a mechanism which allows you to modify some of the diagnostic configuration parameters of the Analog Input Base Converter Module from ladder logic. The Data Command uses the COMMREQ function block and a small block of parameters to update certain configuration parameters on the fly.

Sending Data Commands Using the COMMREQ Function

The PLC ladder program sends a Data Command using the COMMREQ (Communication Request) function. The COMMREQ requires that all its command data be placed in the correct order in the CPU memory before it is executed. It should then be executed by a by a one-shot to prevent sending the data to the module multiple times. Successive COMMREQs must be separated by at least 1 millisecond to guarantee correct processing.

A description of the COMMREQ function and its command block data follows, along with a ladder example which uses registers %R0001 to %R0009 for the COMMREQ command block. Refer to the applicable *Programmable Controller Reference Manual* for additional specific information on COMMREQs.

COMMREQ Function Block Description

The Communications Request (COMMREQ) function is a conditionally executed function that communicates a particular request, through the ladder logic program, to the Analog module.

Communications Request Function Block Format

The ladder logic representation of the COMMREQ function block is as follows:

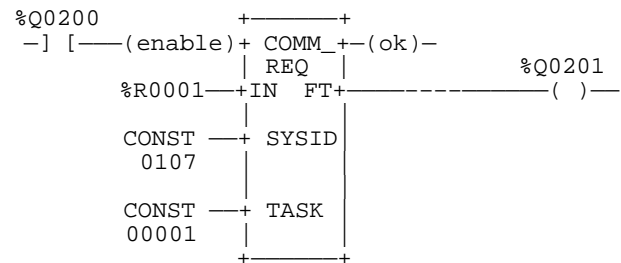

The Communications Request function block has four inputs and two outputs. The first input is an enable input. Generally a one-shot coil is used to enable the COMMREQ function. This prevents multiple messages from being sent. The second input (IN) is the starting location of the COMMREQ command block. The SYSID input is used to indicate which rack and slot to send the message to (physical location of Analog module). The last input (TASK) is set to the channel number to be configured. In the above example, channel 1 of rack 1, slot 7 will be configured and the COMMREQ command block starts at Register 0001.

Power is always passed to the ok output. The fault output (FT) is enabled if the COMMREQ fails.

Analog Input System, High Level, 16 Channels

GFK-0385F
August 1997**Command Block**

The command block for Data Commands is made up of nine words (all values in hexadecimal unless otherwise indicated). Use the block move

command to move these values to the Register tables (refer to the applicable *Programmable Controller Reference Manual*, for information on using the block move function).

Table 5. Command Block for Data Commands

Location	Data	Description
%R0001	0003	Length of data is three words
%R0002	0000	Not used (Always zero)
%R0003	0000	Not used
%R0004	0000	Not used
%R0005	0000	Not used
%R0006	0000	Not used
%R0007	nnnn	Data Command - Command Word - Word 0
%R0008	nnnn	Data Command - Command Word - Word 1
%R0009	nnnn	Data Command - Command Word - Word 2

Analog Input Data Command Parameters

The Data Command can be used to change the configuration of Fault Reporting, Alarm Interrupts, and Alarm

Thresholds for each channel of the Base Converter. Each Data Command reconfigures all of the parameters for the specified channel using the new data.

Table 6. Analog Input Data Command Parameters

Location	Description	Data
Command Word 0	ConfigurationWord	Bit 8: 0 - Fault Report Enable 1 - Fault Report Disable Bit 13: 0 - Alarm Interrupt Disable 1 - Alarm Interrupt Enable
Command Word 1	HighAlarmThreshold	Range +/- 32767 Engineering Units
Command Word 2	LowAlarmThreshold	Range +/- 32767 Engineering Units

Bits in the configuration word are numbered with bit 1 being the least significant bit. Note that changing the configuration of the Alarm Interrupt will have no

effect unless the channel has Alarm Interrupts enabled in the initial configuration folder created using the IC641 configuration software.

GFK-0385F
August 1997

Analog Input System, High Level, 16 Channels

Example - Sending Data Commands

An example of ladder logic for sending a data command to an Analog Input module using COMMREQ function blocks is shown below. In this example, the COMMREQ command block is located in registers %R0001 through %R0009. The command to send the data is initiated by the conditional input %I0289 which sets output %Q0200 for one sweep. The Analog Input module is located in Rack 1, slot 7 (first expansion rack). This command will disable fault re-

porting, enable alarm interrupts, and set the high and low alarm thresholds to +20000 and -20000, respectively.

If the COMMREQ command data is formatted incorrectly, or has an invalid command, the Analog Input module will set the Error Status %I bit, and return an error code in Module Status Code %AI word.

Note that the comments within / . . . */ have been included for information purposes only. They are not generated by the programming software.*

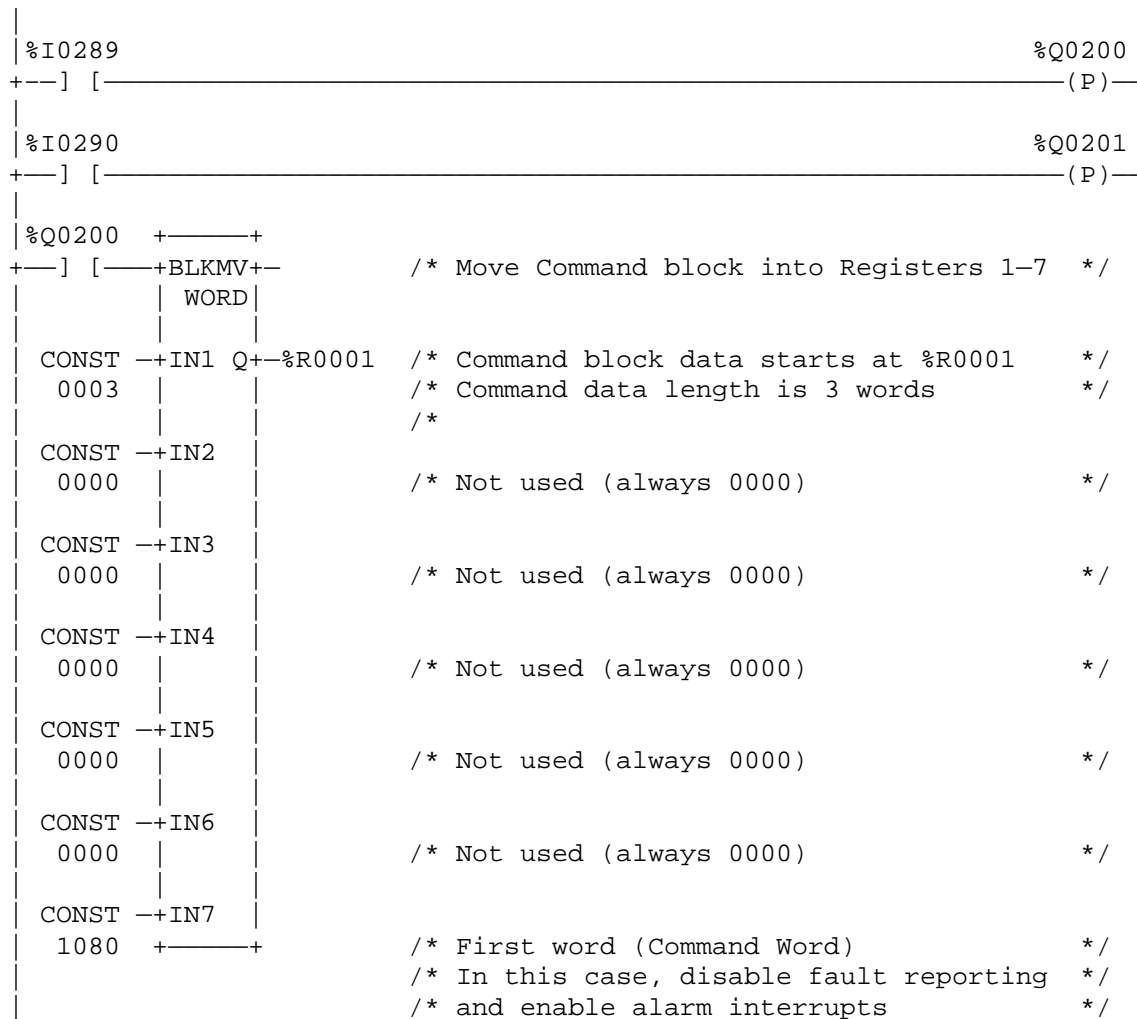

GFK-0385F
August 1997

Analog Input System, High Level, 16 Channels

Diagnostics

Diagnostic capabilities for the analog high level input system include:

- LEDs on modules for system status indication
- Monitoring health of Base Converter and Expander modules
- Detection of configuration errors
- Monitoring communication between Base Converter and Expander modules
- Overrange and underrange detection
- Open wire detection
- Monitoring of high and low alarm limits
- Expander channel not responding

Module LEDs

There are two LEDs on the Base Converter module and one LED on each of the Expander modules.

Base Converter Module

The Base Converter module has two LEDs. The upper LED, labeled **BOARD OK** flashes when the module has powered-up, passed its diagnostic tests, and is waiting for configuration data from the CPU. After receiving configuration data, the Board OK LED is turned on if the data from the CPU is OK; it is turned off if there is a configuration error.

The lower LED, labeled **PORT OK**, turns on when communication is established with one or more Expander modules, and the expansion bus is operating properly. Once the system is up and operating, this LED is turned on when any of the configured expansion channels are responding. When none of the configured expansion channels are responding, the PORT OK LED is turned off

Expander Modules

There is one LED on an Expander module. This LED flashes when the Base Converter module is waiting

for Expander module configuration data. The LED is turned on when the Expander module is configured

The LED is turned off when a board failure has been detected.

Analog Input Diagnostics

Analog input diagnostics, including the Alarm Comparator Function and I/O fault reporting are described below

Alarm Comparator Function

The Alarm Comparator Function provides a mechanism to initiate special processing when an input goes outside a specified operating range. Alarm Thresholds can be set anywhere over the dynamic range of the signal. Typically, they are set at levels beyond which the input should not operate or levels beyond which alternate processing is required. They can also be set beyond the dynamic range of the signal, ensuring that they will never be activated. The desired operating range is defined by user configurable high and low thresholds. The alarms do not affect operation of the module or change the scaled input value. The Alarm Comparator function is available only on the Base Converter module.

Alarm Contacts

When the scaled input value goes outside either of the configured thresholds, the appropriate high (-[HIALR]-) or low (-[LOALR]-) alarm contact for the channel is energized. One alarm is generated each time an alarm threshold is crossed. The IC697 CPU supports one -[HIALR]- and one -[LOALR]- contact pair per channel of the Base Converter module.

Alarm Interrupts

In addition, either alarm will also generate a triggered ladder interrupt, if enabled in the channel configuration. The IC697 CPU supports a separate triggered interrupt block for each input channel. When an alarm interrupt occurs, the CPU updates the data for that channel before activating the interrupt block. Within the interrupt block, the logic can determine which alarm occurred by examining the input data.

Caution

An I/O interrupt can interrupt execution of any program block, including the `_Main` block. Therefore, unexpected results can occur if the interrupt block and the program block access the same data. When it is necessary for a program block and an interrupt block to access the same data, a `SVCREQ #17` can be used to temporarily block the interrupt from executing when the shared data is being accessed.

The execution of a block triggered from an interrupt supersedes the execution of the normal program sequence. Execution of the normal program is suspended, and only resumed after the interrupt block completes.

Alarm Configuration

Each Base Converter channel can be configured to have a high and a low threshold value. Maximum values are ± 32767 . The high threshold must be greater than the low threshold. Threshold limits are based on circuit scaling. If scaling is changed, review and readjust the Alarm Thresholds if necessary.

Note that an alarm threshold of ± 32767 disables the corresponding alarm, thus it is possible to have *only* a high or low alarm. By default, the high and low alarm thresholds are set to $+$ and $- 32767$, respectively.

The alarm thresholds can be changed dynamically using the Diagnostic Config Data Command, described elsewhere in this data sheet.

Use of alarm contacts requires that **Point Faults** be enabled in the CPU, as described in the applicable *Programmable Controller Reference Manual*.

I/O Fault Reporting

The IC697 Analog Input Modules support fault detection which is used to activate fault (`-[FAULT]- / -[NOFL T]-`) ladder contacts in the PLC. In addition, a corresponding fault message is logged in the PLC I/OFault Table, unless fault reporting has been disabled in the channel configuration.

If fault reporting is enabled in the channel configuration, each fault condition is reported once, and is not

reported again until the fault condition is removed and then occurs again.

Fault Contacts

Any combination of the following faults on a channel will cause the corresponding fault contact to be energized. The IC697 CPU supports one `-[FAULT]-` and `-[NOFL T]-` contact pair per input channel on both Base Converter and Expander Modules.

Use of fault contacts requires that Point Faults be enabled in the CPU, as described in the applicable *Programmable Controller Reference Manual*.

Base Converter Faults**Overrange**

Input overrange occurs when either of the following conditions is present:

1. The scaled input value is greater than 32767. Under this condition, the value is held at 32767.
2. The actual input voltage or current is greater than the maximum Analog to Digital converter range (approximately +10.2 volts or 40.8 mA).

Underrange

Input underrange occurs when either of the following conditions is present:

1. The scaled input value is less than -32767 . Under this condition, the value is held at -32767 .
2. The actual input voltage or current is less than the minimum Analog to Digital converter range (approximately -10.2 volts or -40.8 mA).

Open Wire

This diagnostic occurs when a channel is configured for current mode (4-20 mA) operation and the input current drops below 2mA.

Expander Faults**Expander Channel Not Responding**

This fault is a result of a communications failure on the expansion bus, or one or more expansion channels are not responding due to a hardware failure.

Base Converter A/D Communications Fault

This error occurs when certain internal failures occur on the Base Converter module. When this happens, a

GFK-0385F
August 1997

Analog Input System, High Level, 16 Channels

fault message is sent to the CPU by way of a CPU interrupt. The module LEDs are turned off and the module halts after sending the message to the CPU.

Configuration Errors

The following configuration mismatch errors are detected by the Base Converter and reported to the CPU:

- *User scaling error* (user scaling offset calculation exceeds 16 bit signed data)
- *Expander module Configuration Error*, Expander module current or voltage range, or number of channels not as expected

Note

The system cannot determine if terminal board resistors or jumpers for current inputs are properly installed. However, this will often result in overrange faults when current input signals are applied.

User Scaling Error

This error occurs when the user's two scaling points connected on a plot of engineering units versus mV or mA do not cross the engineering unit's X-axis between +32767 and -32767. In other words, 0 mV or 0 mA must correspond to an engineering units number between +32767 and -32767. When this occurs a fault is logged in the PLC I/O Fault Table. The module LEDs are turned off and the module halts after reporting the fault to the CPU.

Expander Module Configuration Error

This error occurs when the Expander module configuration range or the number of channels per Expander module is not as expected. On power-up the Base Converter module scans the Expander modules connected to the expansion bus to determine their type. If the actual configuration does not match the configured range or number of channels, an Expander module Configuration error is reported

Analog Signal Terms

This section explains some general terms relating to measurements at analog I/O terminals.

Single-Ended

Single-ended circuits have the signal measured relative to a common connection, usually the power supply. Other analog I/O signals typically share this common. Single-ended circuits require the fewest terminal points, giving the highest density and lowest price, but at the cost of more restrictive wiring and errors due to voltage drops and currents in the common connections. Single-ended circuit connections are most similar to the wiring of discrete modules.

Signal Common

The term *signal common* refers to a point in the signal that may be connected to the corresponding points in other signal loops. It may or may not be connected to earth ground.

Differential

Differential signals are measured on two wires which are separate, but not isolated from the power supply. Differential inputs allow a greater degree of freedom in wiring commons and grounds without affecting accuracy. There is a limited voltage rating (see Common Mode) between the signal level wires and the power supply wires. This limitation also applies to voltage differences among additional I/O on the same supply.

Differential inputs usually come in groups sharing the supply common tie point. Some voltage outputs may have an *external return* or *remote sense* which allows the load common or ground to be different than the supply of the output module by a small voltage. Current loop signals are less susceptible to differences in voltage between circuit components (see compliance). Differential inputs permit series inputs with current loops, since the signal can be offset from common. Do not confuse differential inputs with isolated inputs; differential requires the common tie point reference for all inputs of the group, usually either ground or the supply common.

Analog Input System, High Level, 16 ChannelsGFK-0385F
August 1997**Isolated**

Isolated inputs are usually two-wire and are dielectrically insulated from supplies and ground. Sometimes additional connections are provided for excitation of transducers such as RTDs, but these signals are not shared with other I/O points. Isolated modules allow high voltages to exist between I/O devices and the PLC. Do not confuse isolated inputs with the isolation between groups of analog circuits, or isolation from other components of the system, such as logic or power supplies.

Normal Mode

This is the actual signal across the signal wires of differential or isolated I/O. This may also include unwanted noise such as power line frequency pickup.

Common Mode

This is the voltage between the analog signal wires and the common point of the power supply of a differential signal, or to ground in the case of an isolated signal. It is desirable that all common mode signals are ignored by the circuit, but in practice there is some error introduced in the data. This is specified as Common Mode Rejection Ratio (CMRR), usually expressed in decibels (db). Differential circuits also have a maximum common mode voltage specifications, usually stated as a maximum voltage with respect to circuit common. Exceeding the common mode voltage rating of differential signals causes large errors in the data conversion and may affect several points.

Unipolar

Unipolar signals or ranges do not change polarity during normal operation; for example 0 to 10 volts, or 4mA to 20mA. Reversed connection to a unipolar

input will produce minimum value and, if diagnostics are available, underrange or open wire faults.

Bipolar

Bipolar signals can reverse polarity in operation. Reversed signal connections to a bipolar input will produce data of opposite sign.

Ground Loop

When a conductor is grounded in more than one place, differences between grounds can induce currents producing voltage drops in the wire. If the conductor is also used to carry an analog signal, these voltage drops produce an accuracy error or noisy values. If a single point ground is used, the voltage difference between locations may still appear in series with the desired signal. This is overcome by using differential or isolated inputs and running a separate return from the remote source. This preserves the integrity of the signal, and the ground voltages appear as common mode voltage at the receiving end.

Current Loop

This is a standard analog interface defined by the Instrument Society of America in ANSI/ISA-S50-1. The signal level is 4mA to 20mA. Three types of signal sources are defined, Types 2, 3, and 4. These correspond to the number of wires used. The isolation of the transmitter may impact the type of PLC input required. When non-isolated inputs are used, isolation may be provided by means of a current transducer that has isolation between the current loop and/or power supply. The Standard covers only isolated or common (single-ended) inputs. Differential inputs often used in PLCs, and connecting several current loops together, as often occurs with PLCs, are not covered well in the Standard, and often introduce additional complication regarding location of commons and grounds.

GFK-0385F
August 1997

Analog Input System, High Level, 16 Channels

Table 7. Analog Input Specifications †

Input Ranges:	Voltage: -10 volts to +10 volts Current: 4 to 20 milliamps
Resolution:	Default Scaling (16 bit) 312.5 microvolts per LSB step on voltage 0.5 microamps per LSB step on 4 to 20 mA No missing codes over 16 bits on voltage No missing codes over 14 bits on current NOTE: User scaling may introduce skipped codes in the lower 2 or 3 bits depending upon the factors used.
Accuracy: Calibration	Factory set at full scale = 10 volts \pm 2 millivolts on Base Converter module. Maximum errors at 25° C (77°F) are: <i>Base Converter Voltage</i> , \pm 0.1% of full scale, \pm 0.2% of value <i>Base Converter Current</i> , \pm 0.05% of full scale, \pm 1% of value <i>Expander Voltage</i> , \pm 0.03% of full value, \pm 0.02% of value <i>Expander Current</i> , \pm 0.07% of full scale, \pm 1% of value
Base Converter	Continually self-calibrates for zero and positive full scale (before user scaling) values. Field calibration not normally required; there is no zero adjustment. A trimpot on the Base Converter adjusts full scale value at 10V input. For critical applications this can be reset to compensate for ageing of the reference.
Accuracy: Linearity Temperature Coefficient	\pm 0.2% of full scale over entire negative to positive range. \pm 5 PPM per °C typical \pm 15 PPM per °C maximum, voltage \pm 30 PPM per °C maximum, current
Input Impedance:	Voltage Inputs: Greater than 10 megohms at DC AC impedance, 20K ohms in series with .47 mfd capacitor. Current Inputs: 250 ohm, 0.1% precision shunt
Common Mode Rejection:	Voltage Range - Peak signal input must be between +13 and -13 volts with respect to the ANLGCOM terminal.
Sensitivity:	Response to common mode signals within the above limits is typically 70 dB CMRR, corresponding to a .02% full scale reading for a 0V input at 10 volts common mode. NOTE: Continuous input signals beyond the common mode range can result in abnormal conversions without causing alarms.
Crosstalk:	High-speed inputs on the Base Converter module may show some interaction between adjacent channels. This is typically .04% of the difference between the affected input and the adjacent channel input levels. The effect can be minimized by arranging inputs with similar levels on adjacent channels. There is no measurable interaction between Expander input channels.
Conversion Rate:	Base Converter inputs updated sequentially about every 2.4 ms to 2.8 ms (maximum) for all 8 channels. One Expander input updated during each scan of the Base Converter inputs. Time between Expander updates = 44.8 x N ms (N = number of Expander modules present).

Analog Input System, High Level, 16 Channels

GFK-0385F
August 1997

Table 5. Analog Input Specifications (continued) †

<p>Response Time:</p>	<p>Each input has a low pass filter with a 100 radian/second (0.01 second) cutoff. A digital filter on the Base Converter input channels adds a second pole at 450 radians/second. A sample and hold maintains full resolution.</p> <p>Settling times, to the specified accuracies, for a zero to full scale step input are as follows:</p> <p>5.0% 30 milliseconds 1.0% 42 milliseconds 0.5% 51 milliseconds 0.1% 67 milliseconds</p>
<p>Input Protection:</p> <p>Impulse:</p> <p>Electrostatic Discharge:</p> <p>Continuous Overvoltage:</p>	<p>Inputs isolated from VME backplane - but not between input channels. They are, however, protected from overvoltage to the levels listed below.</p> <p>Inputs normally not affected by common mode damped ringwave of up to 1000 volts peak. Common or transverse mode peaks up to 2500 volts cause no damage, but may cause occasional bad data if they occur coincidentally with conversion of the affected channel.</p> <p>Inputs survive up to 15KV ESD.</p> <p>Inputs survive common mode or normal mode 120 VAC or 125 VDC fault for at least 1 minute. Longer times may damage input current limiting resistor. Damage limited to only the affected input.</p>
<p>Power Requirements:</p> <p>Rack Backplane</p> <p>Field Side</p>	<p>+5 volts at 0.8A (4 watts) maximum for Base Converter +5 volts at 0.4A (2 watts) for each Expander module</p> <p>No power required for the module; however, current for 4 to 20 mA inputs must be user supplied.</p>

† Refer to GFK-0867B, or later for product standards and general specifications. For installations requiring compliance to more stringent requirements (for example, FCC or European Union Directives), refer to *Installation Requirements for Conformance to Standards*.

Table 8. Ordering Information

Description	Catalog Number
Analog Input Base Converter Module	IC697ALG230
Analog Input Expander Modules	
Current, 4 to 20 mA	IC697ALG440
Voltage, -10 to +10 Volts	IC697ALG441

Note: For Conformal Coat option, or Low Temperature Testing option please consult the factory for price and availability.

GFK-0388G
August 1997

High Level Analog Output System - Voltage/Current Module

Features

- High Level Analog voltage and current outputs on one module
- Output module has four outputs individually configurable for voltage or current
- Provides unipolar or bipolar Analog voltage outputs up to 10 volts full scale
- Provides 0 to 22.5 milliamp current loop signals
- Individual user scaling on each output channel
- Fast update rate
- No jumpers or DIP switches for user to configure
- Calibrated at factory with factory calibration data stored in non-volatile EEPROM memory

Easy configuration using the configuration function of the MS-DOS® or Windows® programming software running on Windows® 95 or Windows NT® over Ethernet TCP/IP or through the SNP port. The Programming Software configuration function is installed on the programming device. The programming device can be an IBM® XT, AT/PS/2® or compatible Personal Computer.

Functions

The high level Analog Output system for the Programmable Logic Controller (PLC) accepts digital data from the CPU or other controllers accessing the PLC backplane. This output data is converted by a Digital to Analog (D/A) converter to analog outputs of up to 10 volts full scale, or 0 to 22.5 milliamp current loop signals.

The basic converter is 16 bits resolution (1 part in 65536) with 14-bit monotonicity. Outputs are isolated from the backplane and are protected against transient and steady-state overvoltage conditions.

Analog outputs use %AQ references in the PLC. A maximum of 8K words of %AQ memory is available in the PLC. Each output channel uses one word (16 bits) of %AQ memory.

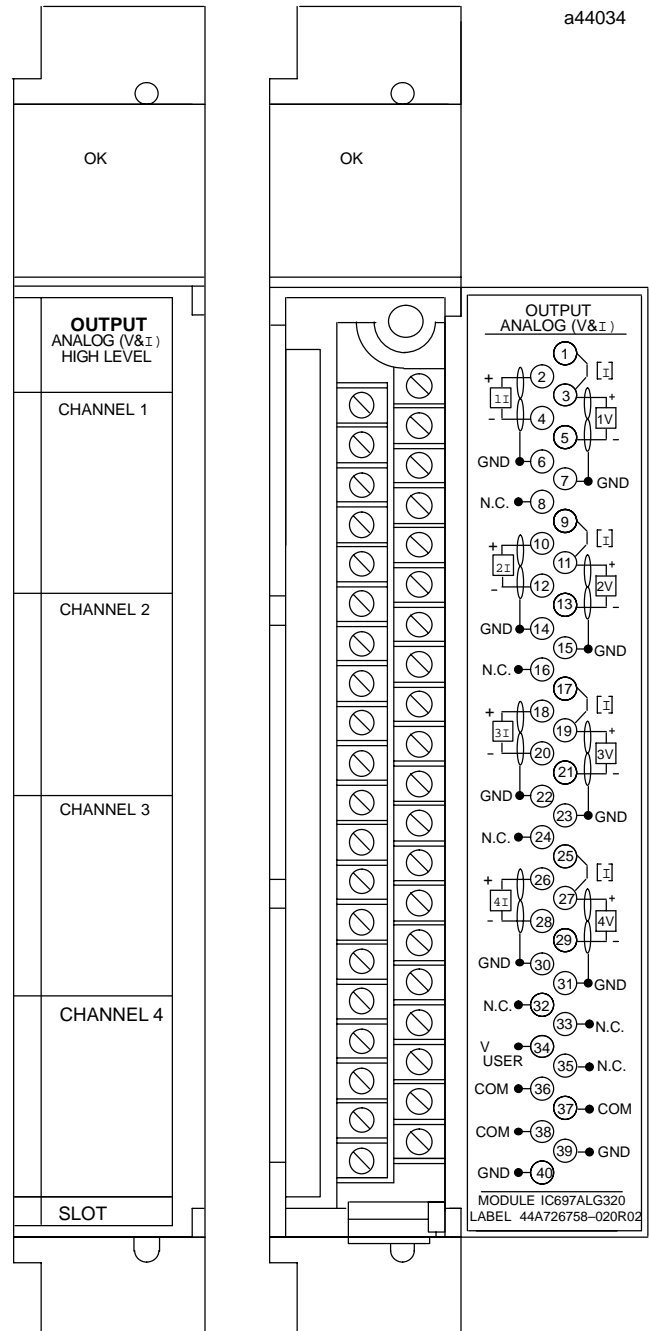

Figure 1. High Level Analog Output Module

© IBM and PS/2 are registered trademarks of International Business Machines Corporation.

© MS-DOS, Windows, Windows 95, and Windows NT are registered trademarks of Microsoft Corporation.

GFK-0388G
August 1997

High Level Analog Output System - Voltage/Current Module

System Operation

A block diagram of the IC697ALG320 High Level Analog Output module and an example of user field wiring connections to the module are shown below.

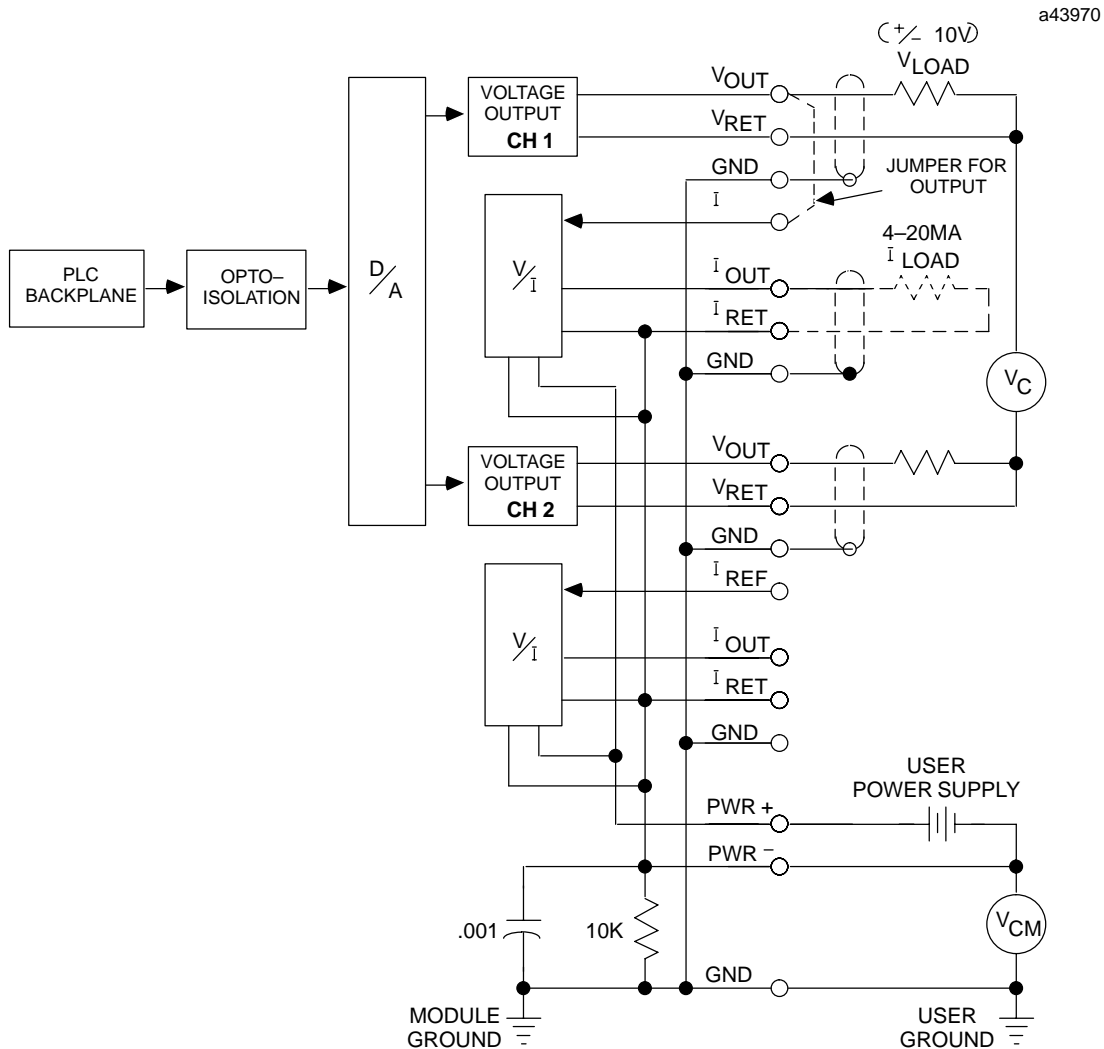

Figure 2. Block Diagram and User Wiring Information for IC697ALG320

Connections for both voltage and current loads are shown in the above illustration. Note the following regarding the illustration:

1. Each output may be configured for either voltage or current - not both.
2. If used as a current output you must jumper V_{OUT} to I_{REF}
3. Power for the voltage output is derived from the PLC backplane. Power for the 4 to 20 mA current output must be supplied by the user. A single connection (PS_{POS} and PS_{NEG}) serves all four channels.

Channel-to-Channel Compliance

While it is expected that output loads will be floating or tied to the same potential (normally ground), the module is designed to allow up to 0.5 VDC compliance voltage (labeled V_C in the previous illustration) difference between outputs and still operate within specifications. This prevents ground loop currents or errors from occurring due to small differences in ground potential at different locations. Note that in addition to this offset, outputs will operate properly in the presence of a large amount of high frequency noise (refer to specifications).

As shown in the previous illustration, the output circuitry is isolated from the PLC backplane. This allows the module to operate within specifications with a common mode voltage of up to ζ 60V from ground (shown as V_{CM} in the illustration). It must be observed, however that the entire output section of the module (all four channels) operates at a **singleoffset** voltage from ground potential. Common mode voltage **between** outputs must be within the specifications stated in the previous paragraph.

User Power for Current Loops

This module will accommodate a wide range of load impedance; up to 800 ohms. The range of allowable power supply voltage for a given load impedance is shown in Figure 3. For example, a 24V ζ 20% supply (19.2 to 28.8 volts) will provide sufficient power with loads from 200 to 550 ohms.

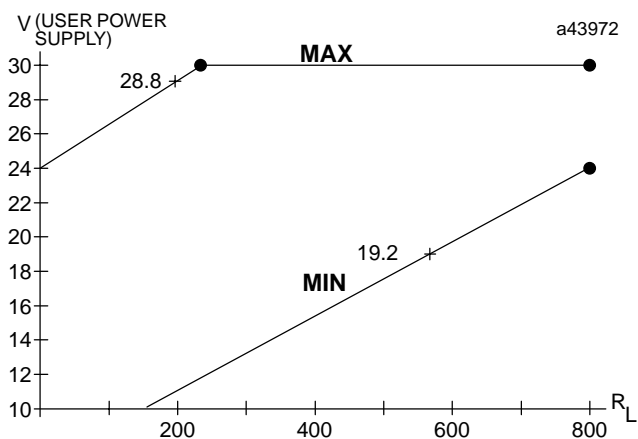

Figure 3. User Power vs. Load Impedance

User Wiring Connections

Figure 4 shows the wiring assignments for the screw terminals on the terminal board on the Analog Output module. In addition to the information in this data sheet, circuit wiring diagrams are printed on the inside surface of the label inserted in the module's hinged door.

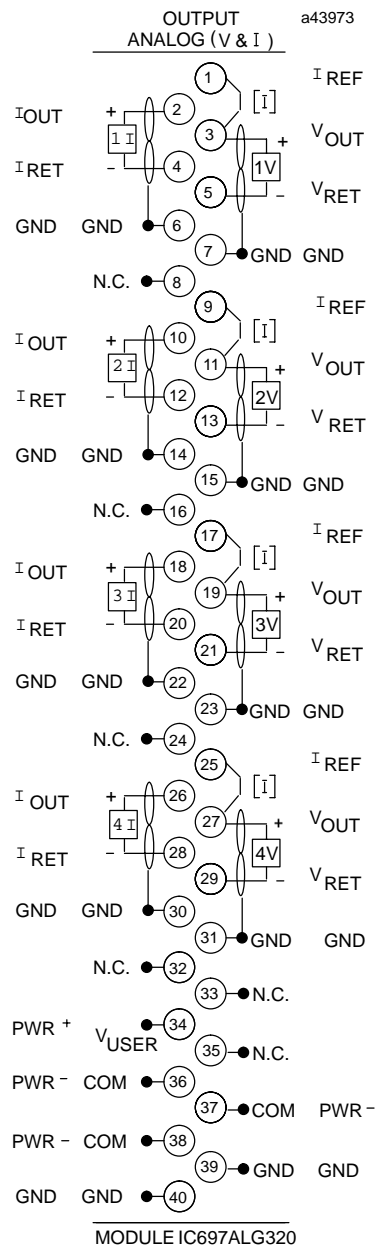

Figure 4. Field Wiring Connections to Module's I/O Terminal Board

GFK-0388G
August 1997

High Level Analog Output System - Voltage/Current Module

Connections to User Devices

Connections to the Analog Output module from user devices are made to screw terminals on a removable 40-terminal connector block mounted on the front of the module. All field connections to the outputs should be wired to the I/O terminal board using a good grade of twisted, shielded instrumentation cable. Separate connections are provided on the terminal board for both current outputs and voltage outputs for each channel. Actual terminals used are determined by the configuration that has been selected for each individual channel.

Ground connections for each channel, labeled GND, on the terminal board are provided for connecting

shields. This ground connection is made directly to the rack, resulting in superior rejection of noise caused by any shield drain currents. Actual selection of ground location may be influenced by system power and ground considerations. However, best operation will be obtained when system ground is physically close to the rack containing the analog circuits. Normally, the shield is grounded at only one end (see Figure 5).

For additional system grounding information refer to the discussion on system grounding in chapter 3 of the Programmable Controller Installation Manual.

The module provides electrical isolation of externally generated noise between the output field wiring and the backplane through use of optical isolation.

VOLTAGE:

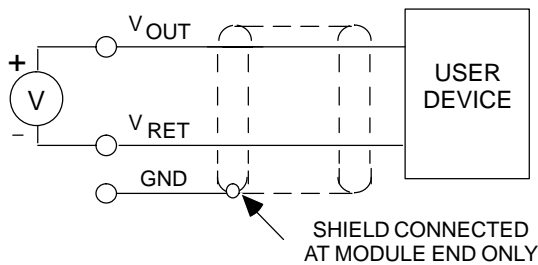

CURRENT:

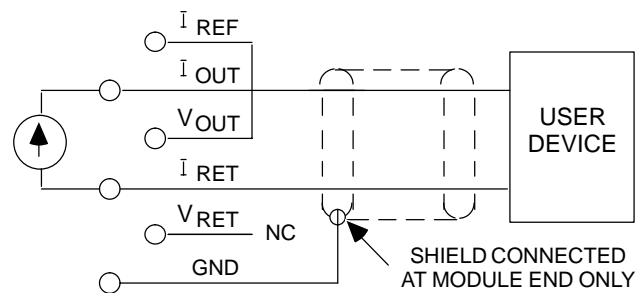

Figure 5. Cable Connections to Field Devices

High Level Analog Output System - Voltage/Current Module

GFK-0388G
August 1997

Recommended Field Wiring Procedures

The following procedures are recommended when connecting field wiring to the detachable terminal

board on the Analog Output module. Module features referenced in the following procedures which are common to all IC697 I/O modules are illustrated in the following figure.

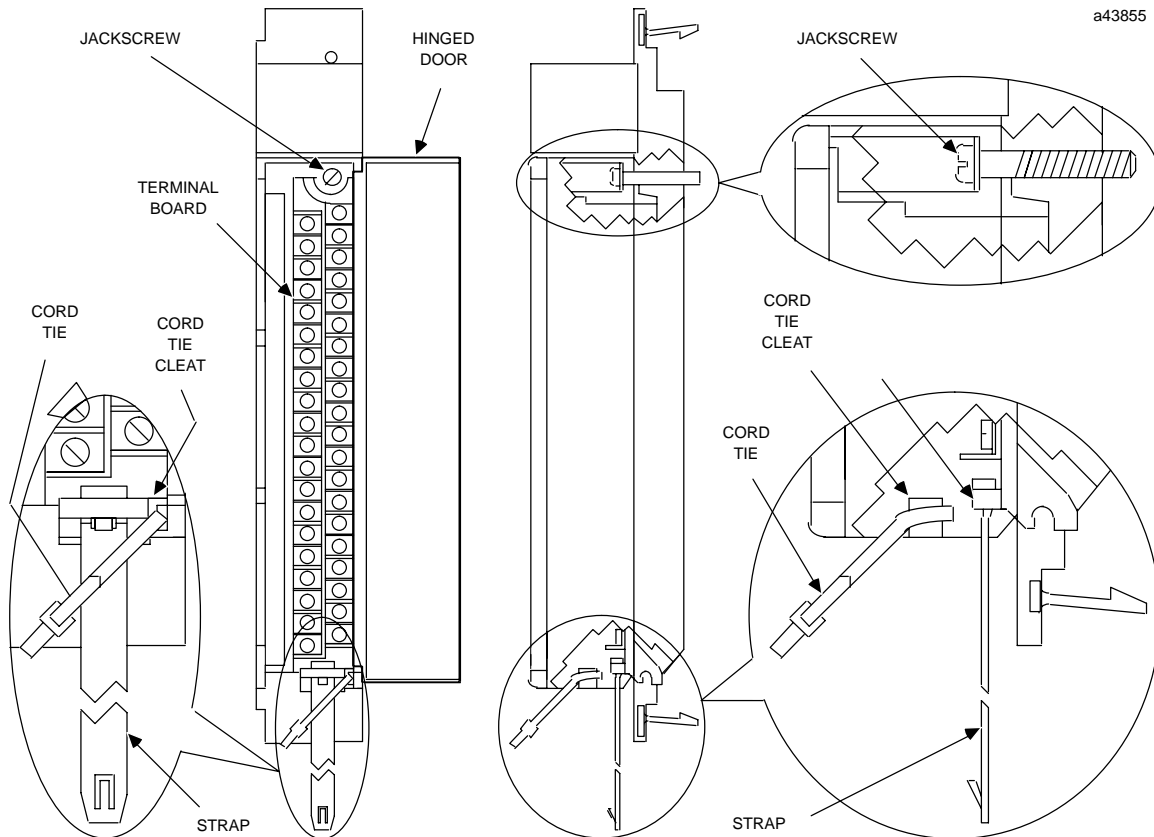

Figure 6. I/O Module Common Features

1. Turn off power before removing or installing terminal boards. Open the hinged door on the module to access a jack screw which holds the terminal board securely in place. The Detachable field wiring terminal board can now be removed from the module by turning the jack screw counter-clockwise until it is fully disengaged.
2. To remove the terminal board, grasp the top of the terminal board and swing it outward.
3. The terminal board is designed to accept wire sizes from AWG #22 (0.36 mm^2) through AWG #14 (2.10 mm^2). It is important that when using AWG #14 (2.10 mm^2) wire for wiring all points, that a maximum insulation diameter of .135 inch (3.43 mm) not be exceeded. To ensure proper connection, two wires may be terminated on any one terminal only if both wires are the same size.
4. The terminal board is designed to accept a maximum of (40) AWG #14 (2.10 mm^2) wires. If AWG #14 (2.10 mm^2) wires are to be used, then wire markers should be placed at least 8 inches (203 mm) from termination end to provide sufficient space for the hinged door to close.

Caution

Do not use the hinged door to remove the terminal board. The hinged door could be damaged if this is done.

GFK-0388G
August 1997

High Level Analog Output System - Voltage/Current Module

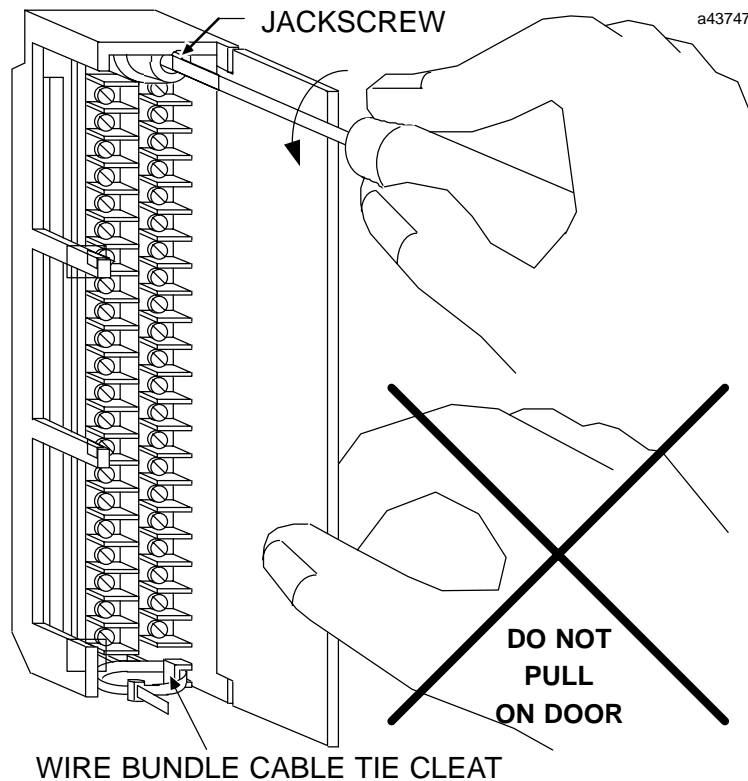

Figure 7. Removal of I/O Terminal Board

5. After completing connections to all modules in a rack, the wire bundle must be secured. To ensure that the wire bundle is secured properly, it is recommended that a cable tie be wrapped around the wire bundle and tightly secured through the cable tie cleat located at the lower right corner of the terminal board. For extremely large wire bundles, additional cable ties should be used.
6. A door label insert is included with each module to indicate circuit wiring information and provide space to record user circuit wiring identification. A slot is provided on the hinged door to allow for insertion of this label. If the label is difficult to insert, crease the scored edge before insertion. The outside label has a color coded stripe to allow quick identification of the module voltage type (*blue*: low voltage; *red*: high voltage).
7. After field wiring is completed, the terminal board should be securely fastened to the rack by inserting the terminal board strap (attached to each module) into the small rectangular slots in the bottom card guide grill on the rack. This strap not

only secures the terminal board to the rack, it also provides a way of identifying the wired terminal board with its correct mating rack slot location.

8. For adequate module ventilation, it is recommended that at least a 5 inch (127 mm) clearance be allowed above and below the rack grill. Wire bundles should not obstruct the rack grill work.

Removing an I/O Module

The instructions below should be followed when removing an I/O module from its slot in a rack.

- Grasp the board firmly at the top and bottom of the board cover with your thumbs on the front of the cover and your fingers on the plastic clips on the back of the cover.
- Squeeze the rack clips on the back of the cover with your fingers to disengage the clip from the rack rail and pull the board firmly to remove it from the backplane connector.
- Slide the board along the card guide and remove it from the rack.

Module/Rack Configuration

A high level analog output system for the programmable controller can consist of multiple Analog Output modules providing up to a maximum of 252 output channels.

A maximum of seven Analog Output modules can be installed in a CPU rack, and a maximum of eight Analog Output modules can be installed in an expansion rack.

Channel numbers for each Analog Output module in a system are assigned by the system.

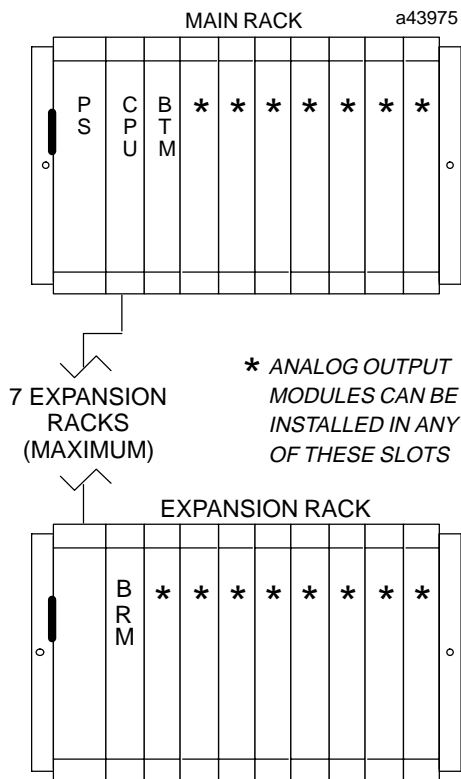

Figure 8. Example of Analog Output Module Installation

Module Mechanical Keying

Each module includes a mechanical key that prevents inadvertent substitution of one module type for another in a given slot. The key fits a uniquely shaped area on the board below the connector.

When the module is first installed, the key latches onto the backplane center rail. When the module is extracted, the key remains in the center rail, thereby

configuring the slot to accept only identical module types.

If it is necessary to change the module location in the rack after the key has been latched onto the center rail of the rack, the key can be removed by pushing it upward to unhook the latch while pushing it off the rail. It may then be reinserted into the rack at the desired location.

Note that in an IC697CHS PLC rack only the power supply can be placed in the leftmost slot in the rack, and slot 1 (adjacent to the power supply) must always contain a CPU (in rack 0 - the CPU rack), or a Bus Receiver Module or Remote I/O Scanner (in expansion racks).

Configurable Functions

You can configure certain functions through the MS-DOS or Windows software configurator function using the programming computer. These functions include output ranges, user scaling, and fault reporting. Each of these functions and their definitions are listed in Table 1.

Module Configuration Data

After the CPU has been updated, the Analog Output module is ready for configuration data. The CPU provides the following module configuration data

- The output circuit type (voltage or current) for each output channel
- CPU fault reporting interrupt, whether enabled or disabled on a per channel
- The default value for outputs and whether outputs are enabled or disabled on system failure or CPU command

Each of the output channel values is checked for over-range, underrange, and open wire; open wire only if configured for current range.

Note

For more detailed information on using the configuration function, refer to the *Programming Software User's Manual*.

High Level Analog Output System - Voltage/Current Module

Table 1. Configurable features for IC697ALG320

Feature	Channel or Module	Selections	Default Setting
Voltage/Current	Channel	-10V, +10V 0V, +10V -5V, +5V 0V, +5V 4, 20 mA	-10V, +10V
Report Faults	Channel	Enabled/Disabled	Enabled
Scaling Points User Value mV or mA	Channel	Ç 32767 µA Ç 10000 mV	+20000, -4000 µA +10000 mV, -10000 mV
Output Default	Channel	Hold/Off	Off
Default Value	Channel	Ç 32767	0

Output Ranges

For each output circuit, the range selected during configuration should match the signal. The 4 to 20 milliamp range can be used for current output devices. For current loop operation, the terminal board jumper for each applicable channel must be installed (refer to Figure 4, Field Wiring Connections to I/O Terminal Board).

Output Default

Output Default mode is activated when the CPU output data is not being received, such as during power-up, when the CPU is stopped, or CPU communications have been lost. When this occurs, each channel

can be configured to *Hold Last State* or default to a configured *Default Value*. If configured to *Hold Last State*, the channel will maintain the last output value received from the CPU until communications resume. If *Output Default* is configured to OFF, the configured Default Value is applied.

Note that the data available to the outputs will be different according to where the system is in relation to time (starting at power-up). This time vs. output data relationship is shown below (Figure 9).

Default Value

If the Output Default is set to OFF, this value, programmed in Engineering Units, is applied to the output until communications are restored.

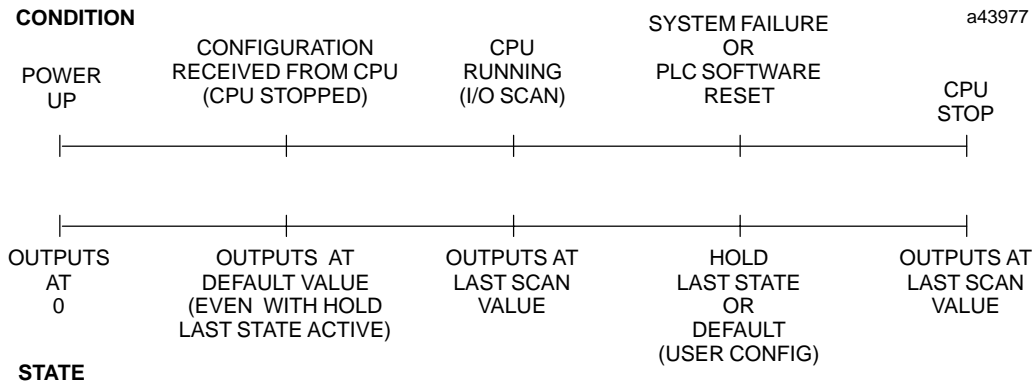

Figure 9. Time vs. Output Data Relationship

High Level Analog Output System - Voltage/Current Module

GFK-0388G
August 1997

User Scaling

User scaling is definable on a per circuit basis on the Analog Output module. The scaling feature allows the user to convert the value in engineering units into millivolts or milliamps as required by the output device being controlled. Engineering units provide measurement that relates to the application, such as, pressure (psi), speed (feet per second), or temperature (degrees F, C, or K). The default configuration for channels configured for voltage, as shown in Figure 10, provides values of -32000 to $+32000$ corresponding to a voltage output range of -10 to $+10$ volts. If a channel is configured for current, default scaling is 0 to 32000 for a current range of 4 to 20 mA (see Figure 11).

Scaling can be configured by the user on a per channel basis with the MS-DOS or Windows programming

software configurator function. Scaling is set by entering the desired voltage or current value and the corresponding engineering units for each of two points. Engineering units are a 16-bit signed value (-32767 to $+32767$). When configuring scale factors, 0 mV or 0 mA must correspond to an engineering unit number between $+32767$ and -32767 .

Note

Scaling to engineering units does not increase the resolution of the value, but does transform it into more convenient units. Scaling can be used to compensate for differences between actual and theoretical values due to inaccuracies encountered in field devices.

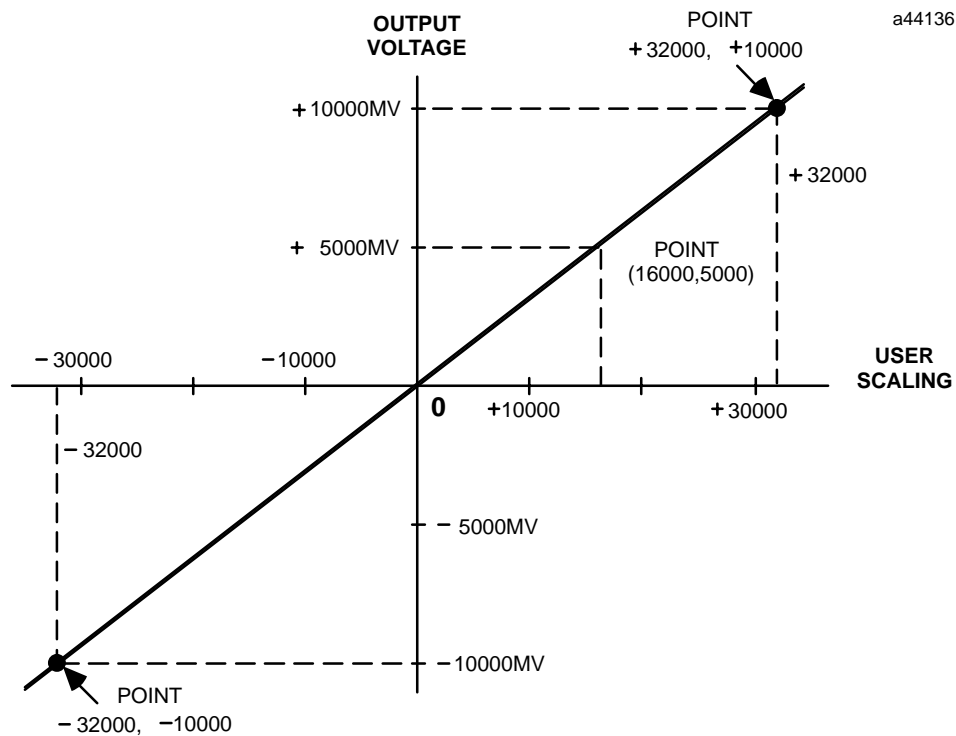

Figure 10. User Scaling for Voltage Output

GFK-0388G
August 1997

High Level Analog Output System - Voltage/Current Module

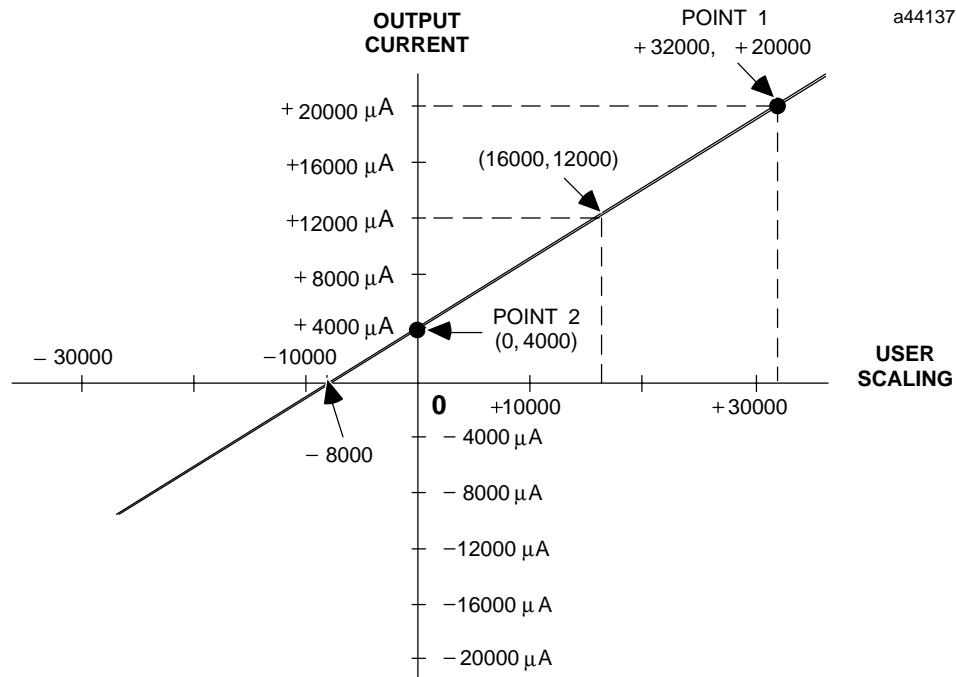

Figure 11. User Scaling for Current Output

Using Data Commands to Modify Configuration

The Data Command provides a mechanism that allows you to modify some of the diagnostic configuration parameters of the Analog Output Module from ladder logic. The Data Command uses the COMMREQ function block and a small block of parameters to update certain configuration parameters on the fly.

Sending Data Commands Using the COMMREQ Function

The PLC ladder program sends a Data Command using the COMMREQ (Communication Request) function. The COMMREQ requires that all its command data be placed in the correct order in the CPU

memory before it is executed. It should then be executed by a by a one-shot to prevent sending the data to the module multiple times. Successive COMMREQs must be separated by at least 1 millisecond to guarantee correct processing.

A description of the COMMREQ function and its command block data follows, along with a ladder example which uses registers %R0001 to %R0008 for the COMMREQ command block. Refer to the applicable *Programmable Controller Reference Manual* for additional specific information on COMMREQs.

COMMREQ Function Block Description

The Communications Request (COMMREQ) function is a conditionally executed function that communicates a particular request, through the ladder logic program, to the Analog module.

Communications Request Function Block Format

The ladder logic representation of the COMMREQ function block is as follows:

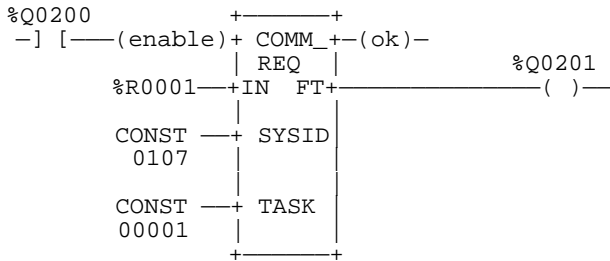

The Communications Request function block has four inputs and two outputs. The first input is an enable input. Generally a one-shot coil is used to enable the COMMREQ function. This prevents multiple messages from being sent. The second input (IN) is the

starting location of the COMMREQ command block. The SYSID input is used to indicate which rack and slot to send the message to (physical location of Analog module). The last input (TASK) is set to the channel number to be configured.

In the above example, channel 1 of rack 1, slot 7 will be configured and the COMMREQ command block starts at Register 0001. Power is always passed to the ok output. The fault output (FT) is enabled if the COMMREQ fails.

Command Block

The command block for Data Commands is made up of eight words (all values in hexadecimal unless otherwise indicated). Use the block move command to move these values to the Register tables (refer to the applicable *Programmable Controller Reference Manual*, for information on using the block move function).

Table 2. Command Block for Data Commands

Location	Data	Description
%R0001	0002	Length of data is two words
%R0002	0000	Not used (Always zero)
%R0003	0000	Not used
%R0004	0000	Not used
%R0005	0000	Not used
%R0006	0000	Not used
%R0007	nnnn	Data Command - Command Word - Word 0
%R0008	nnnn	Data Command - Command Word - Word 1

Analog Output Data Command Parameters

The Data Command can be used to change the configuration of Fault Reporting and Output Default values for each channel. Each Data Command reconfigures

both of the parameters for the specified channel using the new data.

Bits in the configuration word are numbered with bit 1 being the least significant bit.

Table 3. Analog Output Data Command Parameters

Location	Description	Data
Command Word 0	Configuration Word	Bit 5: 0 - Default Outputs 1 - Hold Last State Bit 8: 0 - Fault Report Enabled 1 - Fault Report Disabled
Command Word 1	Output Default Value	Range Ç 32767 Engineering Units

GFK-0388G
August 1997

High Level Analog Output System - Voltage/Current Module

Example - Sending Data Commands

An example of ladder logic for sending a data command to an Analog Output module using COMMREQ function blocks is shown below. In this example, the COMMREQ command block is located in registers %R0001 through %R0008. The command to send the data is initiated by the conditional input %I0289 which sets output %Q0200 for one sweep. The Analog Output module is located in Rack 1, slot 7 (first expansion rack). This command will disable fault re-

porting, and set the high and low alarm thresholds to +20000 and -20000, respectively.

If the COMMREQ command data is formatted incorrectly, or has an invalid command, the Analog Output module will set the Error Status %I bit, and return an error code in Module Status Code %AQ word.

Note that the comments within / . . . */ have been included for information purposes only. They are not generated by the programming software.*

```

|
| %I0289                                     %Q0200
+-- ] [-----] (P)-----
|
| %I0290                                     %Q0201
+-- ] [-----] (P)-----
|
| %Q0200  +-----+
+-- ] [---+BLKMOV+--- /* Move Command block into Registers 1-7 */
|           | WORD |
|           |-----|
| CONST --+IN1 Q+-%R0001 /* Command block data starts at %R0001 */
|   0002 |         | /* Command data length is 2 words */
|         |         | /*
|         |         |
| CONST --+IN2           /* Not used (always 0000) */
|   0000 |         |
|         |         |
| CONST --+IN3           /* Not used (always 0000) */
|   0000 |         |
|         |         |
| CONST --+IN4           /* Not used (always 0000) */
|   0000 |         |
|         |         |
| CONST --+IN5           /* Not used (always 0000) */
|   0000 |         |
|         |         |
| CONST --+IN6           /* Not used (always 0000) */
|   0000 |         |
|         |         |
| CONST --+IN7           /* First word (Command Word) */
|   0080 +-----+ /* In this case, disable fault reporting */
|           |         | /* and default outputs */
|           |         |
|           |         |

```

GFK-0388G
August 1997

High Level Analog Output System - Voltage/Current Module

Analog Output Diagnostics

Diagnostic capabilities for the analog high level output module include:

- LED on modules for system status indication
- Monitoring the health of the module
- Detection of configuration errors
- Overrange detection
- Underrange detection
- Open wire detection

Module LED

There is one LED on the Analog Output module. This LED, labeled **BOARD OK** flashes when the module has powered-up, passed its diagnostic tests, and has configuration data for the CPU. The Board OK LED is turned on if the configurator data from the CPU is OK. It is turned off if there is a configuration error, and a fault is logged in the CPU IO Fault Table.

I/O Fault Reporting

The IC697 Analog Output Modules support fault detection which is used to activate fault (--[FAULT]-- / --[NOFL T]--) ladder contacts in the PLC. In addition, a corresponding fault message is logged in the PLC I/O Fault Table, unless fault reporting has been disabled in the channel configuration.

If fault reporting is enabled in the channel configuration, each fault condition is reported once and is not reported again until the fault condition is removed and occurs again.

Fault Contacts

Any combination of the following faults on a channel will cause the corresponding fault contact to be energized. The IC697 CPU supports one --[FAULT]-- and --[NOFL T]-- contact pair per output channel. Use of fault contacts requires that *Point Faults* be enabled in the CPU, as described in the applicable *Programmable Controller Reference Manual*.

Overrange

Output Overrange occurs when the output is driven beyond the maximum actual output voltage or cur-

rent capability of the Analog to Digital converter (approximately 10 volts or 22.5 mA, respectively). When this occurs, the actual output is clamped at 10.2 volts if configured for voltage operation or 22.5 mA if configured for current mode operation. An Overrange fault is reported to the CPU I/O fault table if Fault Reporting is enabled in the module configuration, and the corresponding Fault Contact is energized if Point Faults are enabled in the CPU configuration.

Underrange

Output Underrange occurs when the output is driven beyond the minimum actual voltage or current capability of the Analog to Digital converter (approximately -10 volts or 0 mA, respectively). When this occurs, the actual output is clamped at -10.2 volts if configured for voltage mode operation, or 0 mA if configured for current mode operation. An Underrange fault is reported to the CPU I/O Fault Table if Fault Reporting is enabled in the module configuration, and the corresponding Fault Contact is energized if Point Faults are enabled in the CPU configuration.

Open Wire

This diagnostic occurs when a channel is configured for current mode (4-20 mA) operation and the output current drops below 1.5 mA. When this occurs, an Open Wire fault is reported to the CPU I/O Fault Table if Fault Reporting is enabled in the module configuration, and the corresponding Fault Contact is energized if Point Faults are enabled in the CPU configuration.

Configuration Errors

The following configuration mismatch errors are detected by the Analog Output module and reported to the CPU.

- *User scaling* error (where user scaling offset calculation exceeds 16-bit signed data)
- *Calibration EEPROM* failure (output calibration data is invalid)

High Level Analog Output System - Voltage/Current Module

GFK-0388G
August 1997**User Scaling Error**

This error occurs when the user's two scaling points connected on a plot of engineering units versus mV or mA do not cross the engineering unit's axis between -32767 and $+32767$. In other words, 0 mV or 0 mA must correspond to an engineering units number be-

tween -32767 and $+32767$. If this condition is not met the result is a configuration user scaling error, and a fault is reported to the CPU. The module LED is turned off and the module halts after sending the message to the CPU. The valid limits for user scaling are shown in the following figure.

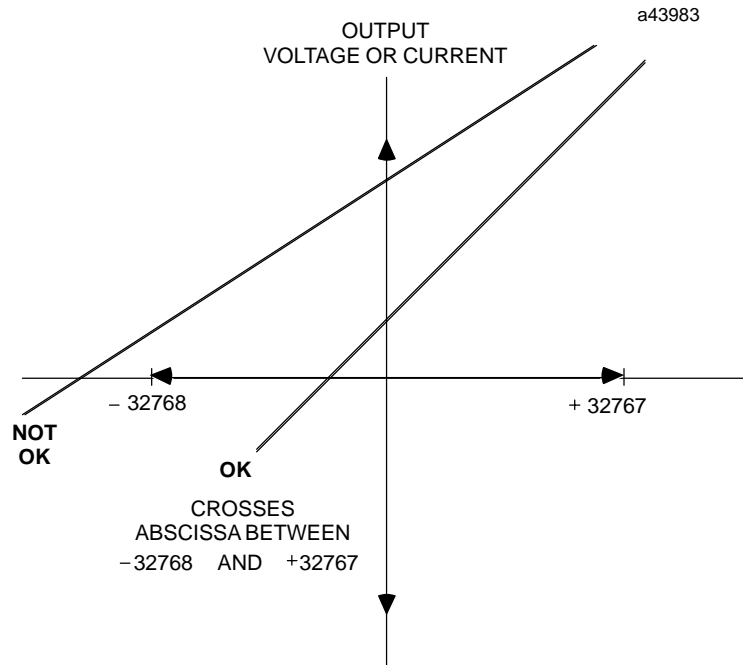

Figure 12. Valid Limits for User Scaling

Calibration EEPROM Failure

During the manufacturing process each channel of the Analog Output module is calibrated for accuracy. If the calibration data becomes corrupted, a *Calibration EEPROM* fault is reported to the CPU. The module LED is turned OFF and the module halts after sending the message to the CPU. This failure is not user serviceable. If it should occur, contact the PLC Hotline for help at 1 800 GE FANUC (1 800 433 2682), or International direct dial 804 978 6036.

GFK-0388G
August 1997

High Level Analog Output System - Voltage/Current Module

Table 4. Analog Output Specifications †

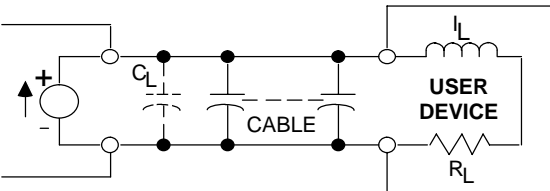
Output Ranges:	Voltage: -10 volts to +10 volts (default) Current: 0.0 mA to 22.5 mA (4 to 20 mA default)
Resolution:	16 bit with 14 bit monotonicity 312.5 microvolts per LSB step on voltage 0.5 microamps per LSB step on 4 to 20 mA No missing codes over 16 bits on voltage. No missing codes over 15 bits on current. NOTE: User scaling may introduce degraded granularity in output voltage depending upon the scaling factors used.
Accuracy: Calibration	Voltage: Factory set at full scale = 10 volts \pm 2.5 millivolts. Current: Factory set at 4.0 mA \pm 5 μ A and 20 mA \pm 5 μ A. Full Scale, with 24.0 VDC field side voltage.
Field calibration not possible	Calibrated at factory with calibration data stored in EEPROM memory.
Maximum Errors	at 25 °C (77 °F)
Linearity	\pm 0.02% of full scale over entire negative to positive range.
Temperature Coefficient	Voltage: \pm 25 PPM per °C typical Current: \pm 50 PPM per °C typical
Output Loading: <i>Voltage:</i>	R: minimum = 2000 ohms C: maximum = 1000 picofarads
<i>Current ‡:</i>	R: up to 800 ohms C: maximum = 1.0 microfarad L: maximum = 250 millihenrys
	‡ The current output should be monitored for stability with step changes using inductive loads. There will be combinations of R, L, and C that will not be stable and will require additional capacitance on the current output terminals to maintain output stability with inductive loads (as shown in the following figure).
	 <p style="text-align: right;">a43976</p>
Short Circuit:	Voltage and current outputs will handle a continuous short circuit without harm and will return to the proper output (output when short occurred) when the short is removed.
Conversion Rate:	All outputs are updated sequentially approximately every 2.0 milliseconds (maximum) for all 4 channels.

High Level Analog Output System - Voltage/Current Module

GFK-0388G
August 1997

Table 4. Analog Output Specifications (continued) †

<p>Response Time: <i>Settling times, to the specified accuracies, for a zero to full scale step output at maximum rated load capacities are:</i></p> <p><i>Voltage:</i></p> <p><i>Current:</i></p>	<p>5.0% 0.5 milliseconds 0.1% 2.0 milliseconds</p> <p>5.0% 1.0 milliseconds 0.1% 5.0 milliseconds</p>
<p>Output Protection:</p> <p>Impulse:</p>	<p>Outputs isolated from VME backplane - but not between output channels. They are designed to have a C 0.5 VDC compliance circuit-to-circuit and operate within specifications. The outputs are protected from overvoltage to the levels listed below.</p> <p>Outputs normally are not affected by common mode damped ring-wave of up to 1000 volts peak. Common or transverse mode peaks up to 2500 volts cause no damage, but may cause occasional bad data if they occur coincident with conversion of the affected channel. The noise level is a direct function of the grade of cable used for connections.</p>
<p>Power Requirements: RackBackplane Field Side</p>	<p>+5 VDC at 1.66A (8.3 watts) maximum</p> <p>150 mA of DC user power must be supplied by the user for the current outputs. The recommended operating voltage is 24 VDC. A range from 10 VDC to 30 VDC (user load impedance dependent, see Figure 3) can be used with some loss in output accuracy.</p> <p>Field side power to the Analog Output module should be connected to the module with a good quality shielded cable in environments where noise could be coupled into the field side power wiring.</p>

† Refer to GFK-0867B, or later for product standards and general specifications. For installations requiring compliance to more stringent requirements (for example, FCC or European Union Directives), refer to *Installation Requirements for Conformance to Standards*.

Table 5. Ordering Information

Description	Catalog Number
High Level Analog Output Module	IC697ALG320

Note: For Conformal Coat option, or Low Temperature Testing option please consult the factory for price and availability.

Special Applications Modules

IC697HSC700

GFK-1057D
August 1997

High Speed Counter

Features

- Single slot module
- Five selectable counter types
- 12 single-ended or differential inputs
- TTL, Non-TTL and Magnetic Pickup input thresholds
- Four positive logic (source) outputs with LED indicators
- External oscillator
- Built-in +5 VDC output
- Software configuration
- Internal module diagnostics
- Module OK and Output State LEDs
- Removable terminal strip for field wiring connections

Configuration is done using the configuration function of the MS-DOS® or Windows® programming software running on Windows® 95 or Windows NT® over Ethernet TCP/IP or through the SNP port. The Programming Software configuration function is installed on the programming device. The programming device can be an IBM® XT, AT, PS/2® or compatible Personal Computer.

Functions

The IC697 High Speed Counter (HSC) module, catalog number IC697HSC700, directly processes rapid pulse signals up to 200 KHz (800 KHz for Type E in A Quad B mode). The module is able to sense inputs, process input count data, and control its outputs without communicating with the PLC CPU. The HSC has a simple and user-friendly PLC interface that makes it extremely useful in industrial applications such as:

- Turbine flowmeter
- Meter proving
- Velocity measurement
- Material handling
- Motion control
- Process control

® IBM and PS/2 are registered trademarks of International Business Machines Corporation.

® MS-DOS, Windows, Windows 95, and Windows NT are registered trademarks of Microsoft Corporation.

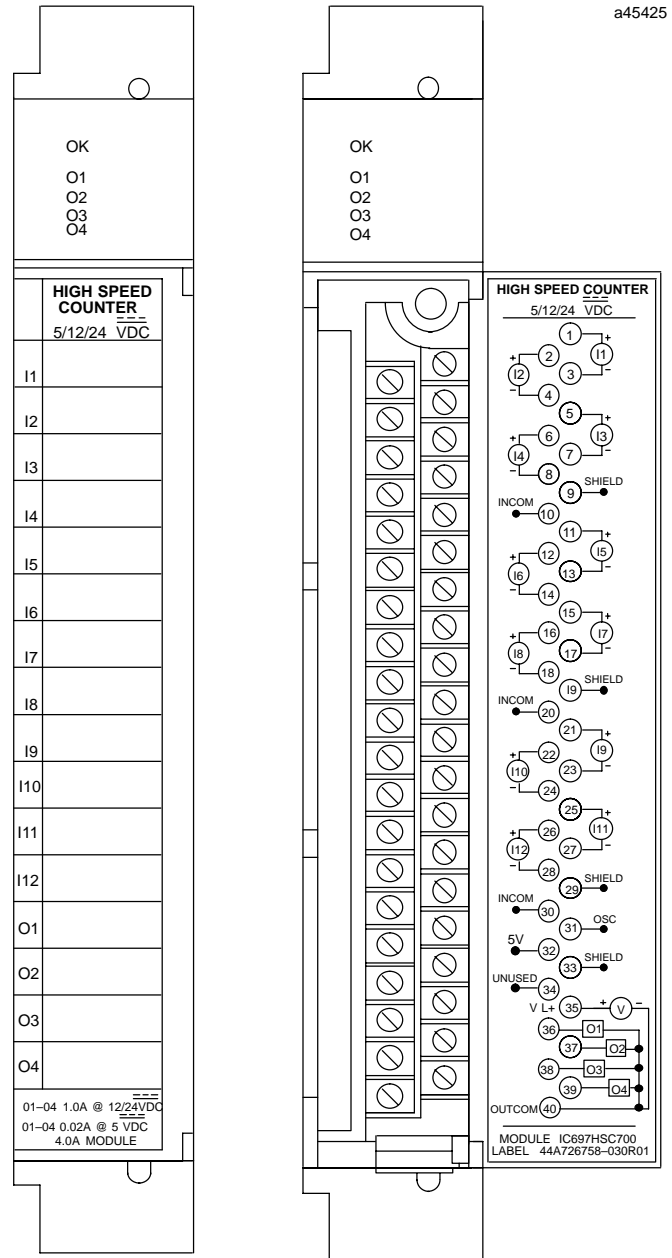

GFK-1057D
August 1997

High Speed Counter

Product Compatibility Requirements

Product	Version
IC697CPU	5.50 or later (CPU models 781, 782, 914, 924)
MS-DOS Programming Software	5.0x or later
Windows Programming Software	1.0 or later

High Speed Counter Types

The High Speed Counter can be configured as one of five types: A, B, C, D, or E. All counters have 12 inputs, four preset outputs, and optional PLC ladder interrupt capability.

Type A

In Type A configuration, the HSC has four identical and independently programmable unidirectional 16-bit counters, which can be configured for up or down operation. Each counter has three inputs: Preload, Count Pulse and Strobe.

Type B

In Type B configuration, the HSC has two identical and programmable bi-directional 32-bit counters. Each counter can be independently configured to operate in Up/Down, Pulse/Direction or A Quad B mode. Both counters have two independent Strobe inputs and Strobe registers. Each counter has a single Preload input to set the accumulator and a Disable input to suspend counting.

This counter type can be configured to link strobes. In this mode, a count on the Counter 2 inputs will strobe both Counter 1 and Counter 2 Accumulator values into their respective Strobe 1 registers. This feature can be used to accurately measure a pulse rate against a reference pulse or to compare two different pulse rates.

Type C

In Type C configuration, the HSC has one differential bi-directional 32-bit counter with a Disable input to suspend counting. It also provides a Home cycle to initialize the accumulator to a pre-defined Home Position. A Home Switch input and a Marker input are used to indicate the Home Position to each counter input. The configured Home value specifies the accumulator value at the Home Position.

Two sets of bi-directional counter inputs can be connected differentially. Each pair of inputs can be configured for Up/Down, Pulse/Direction or A Quad B mode. The Type C configuration has three Strobe registers with Strobe inputs and two Preload values with Preload inputs.

Type D

In Type D configuration, the HSC has four bi-directional 32-bit counters that can be configured to count in Up/Down, Pulse/Direction, A Quad B x1, A Quad B x2, or A Quad B x4 mode. Each counter has a marker input which can be used to set its accumulator value to the counter's Home Position value. When configured in A Quad B mode, the High Speed Counter detects and reports quadrature errors.

Type E

The Type E counter contains two identical 16-bit counters with Strobe and Preload inputs capable of counting Up/Down or A Quad B signals. Each has a Count Disable and a Strobe Disable input. The Type E counter is designed primarily as a Down counter, but can handle up counts to account for A Quad B *jitter*. When a counter counts down to zero, it turns on a dedicated preset output with a 5 μ s response.

Type A, B, C, and D Operating Features

Operating features of the High Speed Counter for Types A, B, C, and D are described below. Features that have selectable parameters are configured using the MS-DOS or Windows programming software configurator function that has been installed on your programming computer. For detailed information about selectable features, refer to the *High Speed Counter User's Manual*, GFK-1062.

Count Rate

Maximum count rates are 200 KHz with the high frequency filter and 30 Hz with the low-frequency filter.

Selectable Input Filters

The Count, Count Disable, and Preload inputs for each counter can be configured for a high frequency filter (2.5 microseconds) or a low-frequency filter (12.5 milliseconds).

High Speed Counter

GFK-1057D
August 1997

Continuous or Single-Shot counting

Each counter can be configured to operate in either continuous or single-shot mode.

Continuous Counter Mode: If either the upper or lower count limit is exceeded the counter wraps around to the other limit and continues.

Single-shot Counter Mode: The counter counts to either the upper or lower limit and stops. When the counter is at the limit, counts in the opposite direction back it off from the limit.

Counter Accumulator

The Accumulator contains the current count value of each counter. The CPU can read the accumulator value or set it from the application program.

Counts per Timebase Register

Each counter stores the number of counts that have occurred in a specified period of time. A timebase value from 1 ms to 65535 ms can be configured.

Strobe Register

Type A, B and C counters have one or more Strobe registers that capture the current Accumulator value when a Strobe input transitions. The Strobe inputs are edge-triggered and can be configured for positive-edge or negative-edge response. The Strobe registers can be configured to update at any Strobe trigger or only on the first strobe trigger

Preloads

Counters A, B and C have one or more Preload inputs. The Preload inputs set the accumulator to a configured Preload value. %Q bits sent from the PLC can also be used to generate Preload and set the accumulator to the configured Preload value.

Selectable On/Off Output Presets

Counter output signals can be configured to be On or Off when the count Accumulator reaches configured

On and Off Preset values. There are four On/Off Preset outputs which can be independently assigned to any counter. An assigned output's state indicates when the counter Accumulator is between the defined On and Off points. Output polarity can be configured to On only between points or Off only between points by the relative location of the On/Off Presets.

Selectable Preset Interrupts

Each Preset output can generate PLC interrupts from On and/or Off transitions. Interrupts can be enabled for either or both transitions of each Preset output.

Oscillator

The module provides an external oscillator output that can be wired as a count input to any counter and used as a timing reference for measurement. The 5V square wave oscillator output can be configured to operate at frequencies from 15 Hz to 1 MHz. This output has a CMOS buffer with a 47 ohm output impedance.

Data Commands

The PLC can send data commands to the HSC through %AQ data or with a COMMREQ. These commands allow the user to dynamically modify counter operation and configuration parameters. Configuration parameters that can be dynamically modified include: accumulator value, counter limits, Preload values, On and Off Preset values and Home Position.

Velocity Command

A %AQ or COMMREQ Data Command can be used to generate an internal velocity of up to 100,000 counts per second. The counter accumulator will increment or decrement at the commanded velocity. Counts generated by the user count inputs will be accumulated in addition to the Velocity Command counts.

Accumulator Adjust

A data command can be used to adjust the accumulator value from -128 to +127 counts at any time.

GFK-1057D
August 1997

High Speed Counter

Type E Operating Features

Operating features of the High Speed Counter for Type E are described below.

Count Rate and Input Filters

The maximum count rate with the low-frequency filter (12.5 milliseconds) is 30 Hz; with the high-frequency filter (2.5 μ s), the maximums are 200 KHz in Up/Down mode and 800 kHz in A Quad B mode. The Count, Count Disable, and Preload inputs for each counter can use either filter, but the Strobe and Strobe Disable inputs use only the high-frequency filter.

Continuous or Single-Shot Counting

Each counter can be configured to operate in either continuous or single-shot mode.

Continuous Counter Mode: When the counter decrements to zero, it turns on the fast response output and automatically preloads itself to the preload value and continues counting.

Single-shot Counter Mode: When the counter counts to zero, it turns on the fast response output and ignores count pulses until a preload occurs.

Preloads

A rising edge on the Preload input, a rising edge on the %Q Preload Accumulator bit, or the counter decrementing to zero in Continuous mode will set the accumulator to a configured Preload value. Preloads caused by the Preload input and count decrementing to zero will set a %I bit in the PLC to indicate a preload occurred.

Strobe Register Stack

Each counter has a Strobe Register stack which will store up to four strobe values. Strobes can be configured to occur on rising, falling, or both edges of the Strobe input. %I bits indicate how many strobes have occurred. A Reset Strobes %Q bit or a Preload clears the Strobe Register stack and %I indicators. A Strobe Disable input causes all Strobe input transitions to be ignored.

Counter Outputs

The Type E counter supports two types of output presets, Fast Response and Standard.

Fast Response: There is one dedicated fast response output for each accumulator. The fast response output turns on within 15 μ s of the associated counter decrementing to zero, with less than 2 μ s variation. In addition, two output modes are supported for the fast response outputs.

Pulse Output Mode: The output turns on when the Accumulator counts down to zero and stays on for a configured duration, from 1 to 1000 milliseconds.

Latched Output Mode: (Single Shot mode only) The output turns on when the Accumulator counts down to zero and stays on until a Preload occurs.

Standard Output Presets: Outputs 3 and 4 can be assigned to either counter and configured to be On or Off when the count Accumulator reaches configured On and Off values. An assigned output's state indicates when the counter Accumulator is between the defined On and Off points.

Output Interrupts

Interrupts can be enabled or disabled for Off to On transitions of the fast response outputs. Interrupts can be enabled or disabled for either transition of the standard preset outputs.

Oscillator

The module provides an external oscillator output that can be wired as a count input to any counter and used as a timing reference for measurement. The 5V square wave oscillator output can be configured to operate at frequencies from 15 Hz to 1 MHz. This output has a CMOS buffer with a 47 ohm output impedance.

Data Commands

The PLC can send data commands to the HSC through %AQ data or with a COMMREQ. These commands allow the user to dynamically modify counter operation and configuration parameters. Configuration parameters that can be dynamically modified include: Preload values, On and Off Preset values, and Fast Response output duration.

High Speed Counter

GFK-1057D
August 1997

Location in a System

A High Speed Counter module can be installed in any I/O slot in the CPU rack or in any I/O slot in an expansion rack in a system. For interrupts to work, there can be no empty slots

between the CPU and the HSC. The following figure shows two typical installations: (A) a High Speed Counter installed in the CPU rack in a single rack installation and (B), multiple High Speed Counter modules installed in an expansion rack in a multiple rack system.

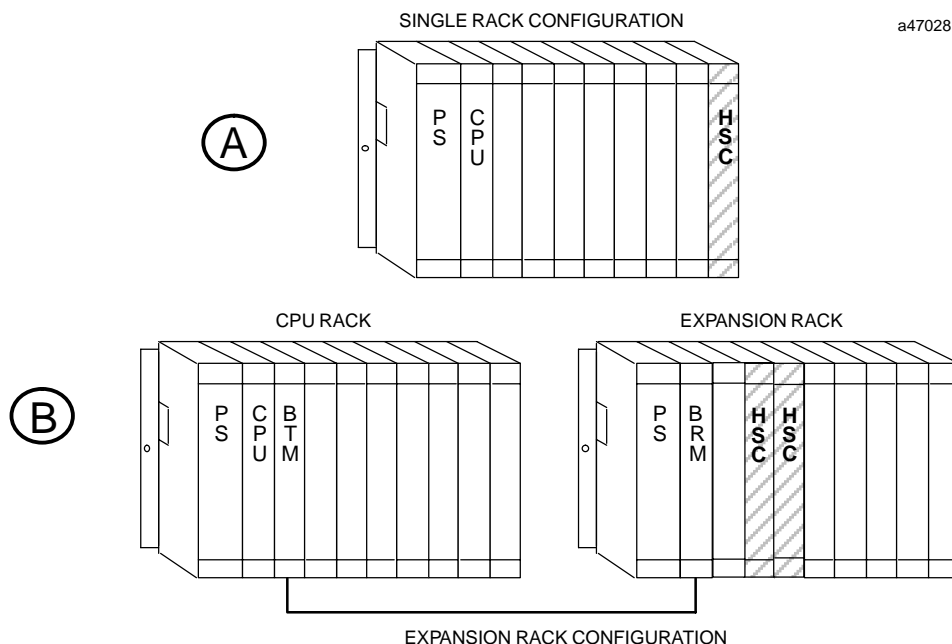

Figure 1. Example of High Speed Counter Module Installation Configurations

Installing a High Speed Counter

For detailed instructions on how to install a High Speed Counter module, refer to *Installation Procedures* in the applicable *Programmable Controller Installation Manual*. Also refer to the *High Speed Counter User's Manual*. Following is a basic description of the module (refer to Figure 2 for location of hardware features).

Status Indication

Five status LEDs are viewable on the module as shown in Figure 2. The function of each LED is as follows:

MODULE OK LED

The MODULE OK LED indicates current status of the High Speed Counter module as described in Table 1.

Table 1. MODULE OK LED Status

State	Description
OFF	When the MODULE OK LED is off, the High Speed Counter module is <i>not</i> functioning. This is the result of a hardware malfunction; for example, the diagnostic checks detected a failure, or the PLC CPU is <i>not</i> present. Corrective action is required in order to get the module functioning again.
ON	When the LED is on steadily, the High Speed Counter module is functioning properly. Normally, this LED should <i>always</i> be on, indicating that the diagnostic tests were successfully completed and the programming software configuration data for the module is correct.
Flashing	The LED flashes at a 1 Hz rate when power-up diagnostics have completed successfully and the module is waiting for configuration. It also flashes at a 4 Hz rate when an error occurs. When the error is cleared, the LED will return to being on steadily.

GFK-1057D
August 1997

High Speed Counter

Output LEDs (O1 - O4)

These four LEDs indicate the ON/OFF state of the corresponding module output circuit. The output circuits can be used to drive indicating lights, solenoids, relays, and other such similar devices. The LEDs are either ON or OFF (output activated or not activated).

User Terminal Connector

The removable terminal strip has 40 screw terminals for connection to field devices to the High Speed Counter inputs and outputs. Pin assignments for field wiring connections are provided in the following table. For detailed information on how each signal applies to the different counter types, refer to the *High Speed Counter User's Manual*.

Table 2. User Terminal Connector Pin Assignments

Pin Number	Signal Name	Pin Number	Signal Name
1	IN1P	21	IN9P
2	IN2P	22	IN10P
3	IN1M	23	IN9M
4	IN2M	24	IN10M
5	IN3P	25	IN11P
6	IN4P	26	IN12P
7	IN3M	27	IN11M
8	IN4M	28	IN12M
9	SHIELD	29	SHIELD
10	INCOM	30	INCOM
11	IN5P	31	OSC
12	IN6P	32	5VP
13	IN5M	33	SHIELD
14	IN6M	34	not used
15	IN7P	35	OUTPWR
16	IN8P	36	OUT1
17	IN7M	37	OUT2
18	IN8M	38	OUT3
19	SHIELD	39	OUT4
20	INCOM	40	OUTCOM

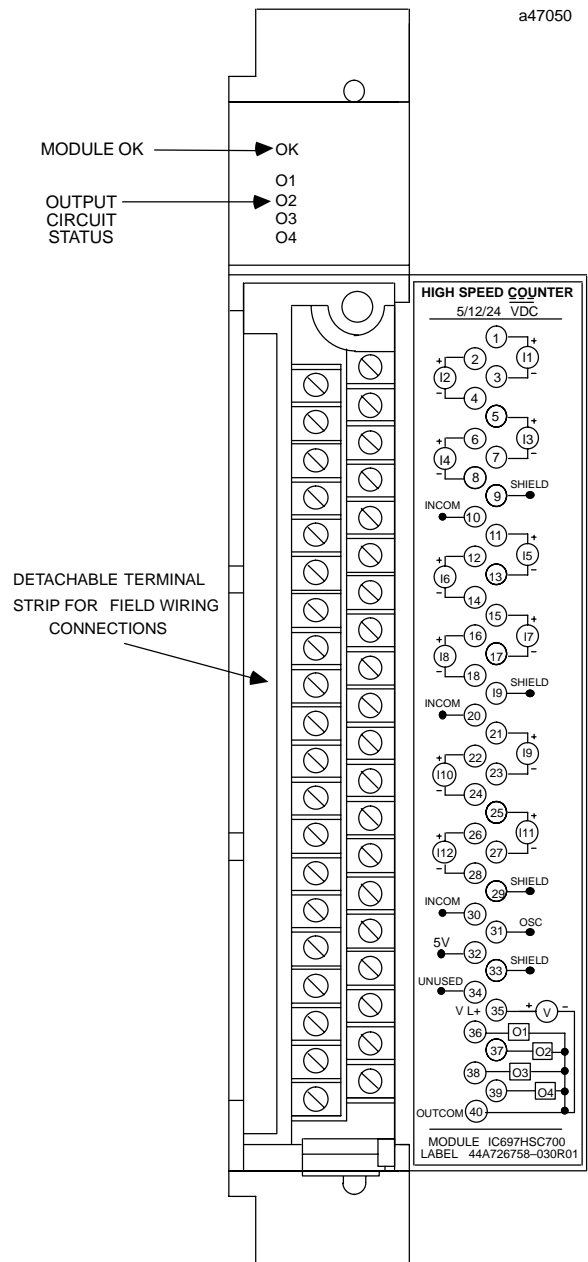

Figure 2. High Speed Counter Module - User Features

High Speed Counter

GFK-1057D
August 1997

Recommended Field Wiring Procedures

The following procedures are recommended when connecting field wiring to the detachable terminal board on the High

Speed Counter module. Module features referenced in the following procedures which are common to most IC697 I/O modules are illustrated in the following figure.

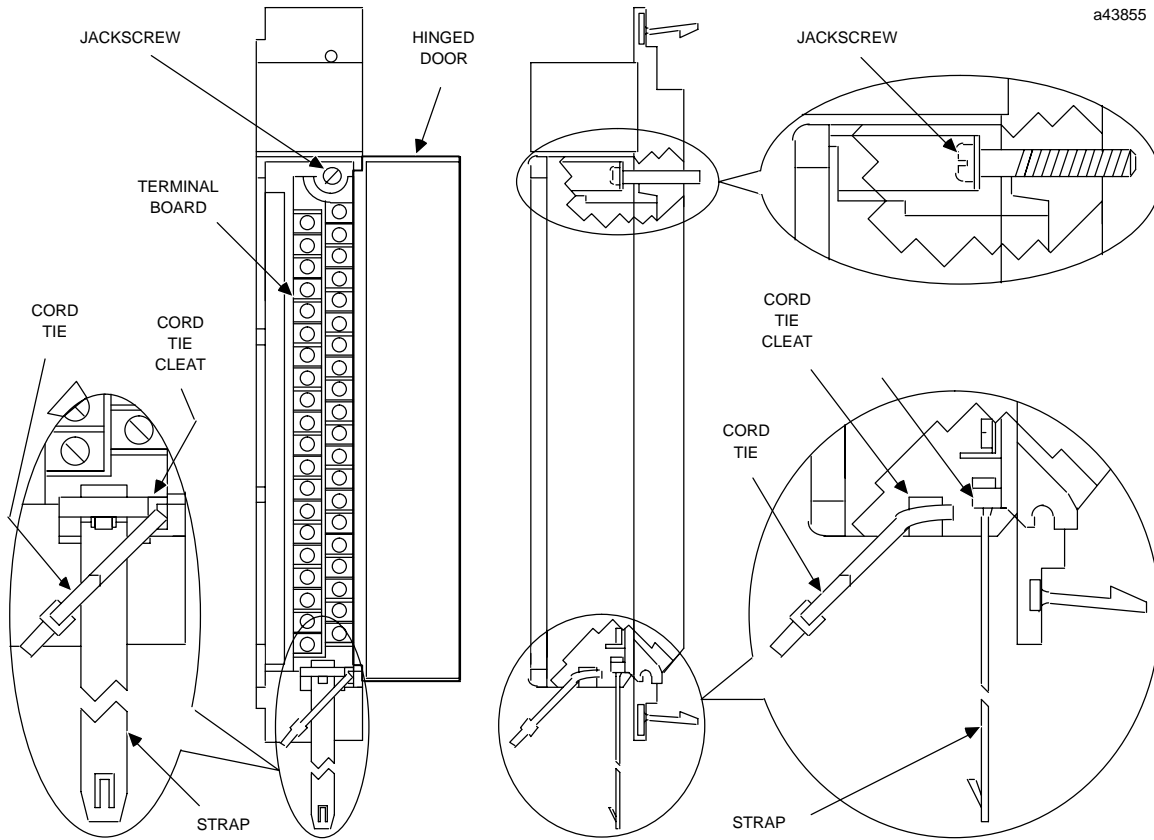

Figure 3. I/O Module Features

1. Turn off power before removing or installing terminal boards. Open the hinged door on the module to access a jackscrew which holds the terminal board securely in place. The detachable field wiring terminal board can now be removed from the module by turning the jackscrew counter-clockwise until it is fully disengaged.
2. To remove the terminal board, grasp the top of the terminal board and swing it outward.
3. The terminal board is designed to accept wire sizes from AWG #22 (0.36 mm²) through AWG #14 (2.1 mm²). It is important that when using AWG #14 (2.1 mm²) wire for wiring all points, that a maximum insulation diameter of .135 inch (3.43mm) not be exceeded. To ensure proper connection, two wires may be terminated on any one terminal only if both wires are the same size.
4. The terminal board is designed to accept a maximum of (40) AWG #14 (2.1 mm²)wires. If AWG #14 (2.1 mm²) wires are to be used, then wire markers should be placed at least 8 inches (203 mm) from termination end to provide sufficient space for the hinged door to close.

Caution

Do not use the hinged door to remove the terminal board. The hinged door could be damaged if this is done.

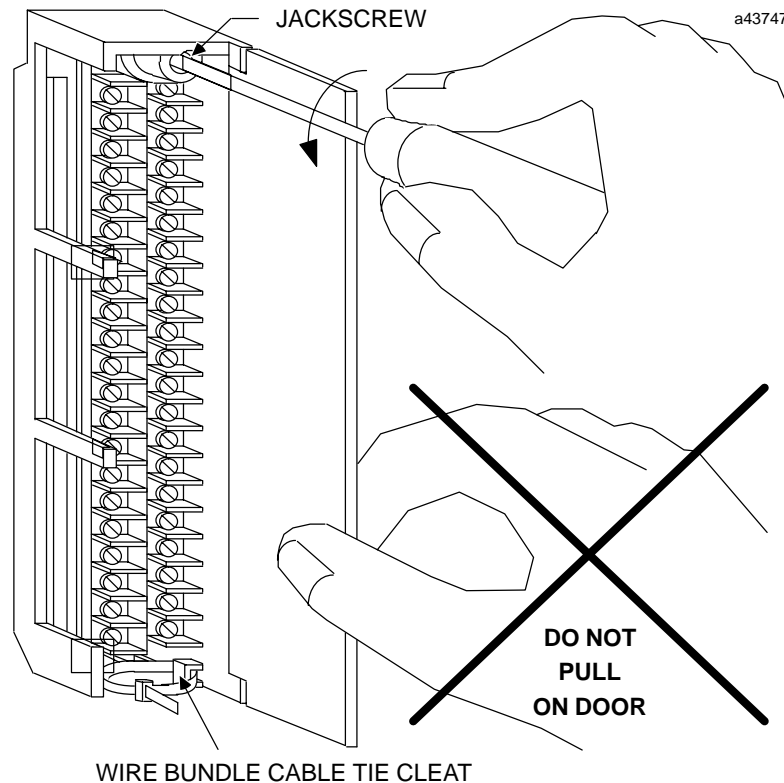

Figure 4. Removal of I/O Terminal Board

5. After completing connections to all modules in a rack, the wire bundle must be secured. To ensure that the wire bundle is secured properly, it is recommended that a cable tie be wrapped around the wire bundle and tightly secured through the cable tie cleat located at the lower right corner of the terminal board. For extremely large wire bundles, additional cable ties should be used.
6. A door label insert is included with each module to indicate circuit wiring information and provide space to record user circuit wiring identification. A slot is provided on the hinged door to allow for insertion of this label. If the label is difficult to insert, crease the scored edge before insertion. The outside label has a color coded stripe to allow quick identification of the module voltage type (blue: low voltage; red: high voltage).
7. After field wiring is completed, the terminal board should be securely fastened to the rack by inserting the terminal board strap (attached to each module) into the small rectangular slots in the bottom card guide grill on the rack. This strap not

only secures the terminal board to the rack, it also provides a way of identifying the wired terminal board with its correct mating rack slot location.

8. For adequate module ventilation, it is recommended that at least a 6 inch (152mm) clearance be allowed above and below the rack grill. Wire bundles should not obstruct the rack grill work.

Removing an I/O Module

The instructions below should be followed when removing an I/O module from its slot in a rack.

- Grasp the board firmly at the top and bottom of the board cover with your thumbs on the front of the cover and your fingers on the plastic clips on the back of the cover.
- Squeeze the rack clips on the back of the cover with your fingers to disengage the clip from the rack rail and pull the board firmly to remove it from the backplane connector.
- Slide the board along the card guide and remove it from the rack.

Table 3. Specifications for IC697HSC700 †

General: Module Operating Voltage Module Current Drain Maximum Count Rate Types A - D, and Type E in Up/Down mode Type E in A Quad B mode Output Points LEDs Input and Output Isolation Peak (1 second) Steady Status	5 VDC (from backplane) 1A + (10 mA x number of ON outputs) + (1.6 x encoder current) 200 KHz 800 KHz Powered by user supplied 5V, or 10 to 30 VDC MODULE OK and O1 - O4 (Output circuit. status) 1500volts 30 V AC/DC												
Inputs Voltage Range TTL Non-TTL Magnetic Pickup (I1 to I4 only) Input Thresholds (I1 to I12) Von Voff Encoder Power Input Filter Delay IN1 to IN8 IN9 to IN12 Input Impedance Input Hysteresis Input Cable	5 VDC 10 to 30 VDC 400 mV <table border="0"> <tr> <td></td> <td><i>TTL</i></td> <td><i>Non-TTL</i></td> <td><i>Magnetic Pickup</i></td> </tr> <tr> <td>Von</td> <td>1.4V</td> <td>8.0V</td> <td>400 mV</td> </tr> <tr> <td>Voff</td> <td>0.8V</td> <td>5.0V</td> <td>200 mV</td> </tr> </table> 5 VDC, 500 mA @40°C (104°F), 300 mA @60°C (140°F) 10 ms or 2 µs selectable 2 µs 6000 ohms 250 mV typical Shielded cable recommended Maximum length: 30 meters (100 feet)		<i>TTL</i>	<i>Non-TTL</i>	<i>Magnetic Pickup</i>	Von	1.4V	8.0V	400 mV	Voff	0.8V	5.0V	200 mV
	<i>TTL</i>	<i>Non-TTL</i>	<i>Magnetic Pickup</i>										
Von	1.4V	8.0V	400 mV										
Voff	0.8V	5.0V	200 mV										
Outputs Output Type Maximum Supply Voltage Maximum Output Current at 60°C (140°F) Output Current using 5 VDC supply Inductive Load Clamp Voltage OFF State Leakage Current	Positive Logic, optically isolated 30.0 VDC 1.0 A for each output using 10 to 30 VDC supply 20 mA typical -8.0 V typical 10 µA for each output												

Table 3. Specifications for IC697HSC700 (continued)

Output Response Time Type A - D, Type E Slow Response	300 μ s typical 650 μ s worst case
Type E Fast Response	24 Volts On: 7 μ s typical 10 μ s worst case Off: 56 μ s typical 5 Volts On: 10 μ s typical 15 μ s worst case Off: 63 μ s typical
Output Response Variation Slow Response	650 μ s worst case
Fast Response	1 μ s worst case
Output Protection	5.0 A fuse (5x20mm replaceable) common to all outputs
VME	System designed to support the VME standard C.1

† Refer to GFK-0867B, or later for product standards and general specifications. For installations requiring compliance to more stringent requirements (for example, FCC or European Union Directives), refer to *Installation Requirements for Conformance to Standards*.

Table 4. Ordering Information

Description	Catalog Number
HighSpeed Counter Module	IC697HSC700

Note: For Conformal Coat option, or Low Temperature Testing option please consult the factory for price and availability.

GFK-0734C
August 1997

State Logic Processor Module (SLP)

Features

- Natural English Language Programming using ECLiPS™
- Structured State Logic program architecture
- Advanced Diagnostics
- Simulation capabilities
- PID Loop control
- Handles complex math easily (floating point, square root, trig. functions)
- Allows any combination of Natural English State Logic and Ladder Logic programs in same system
- Configurable to operate with any IC697 PLC
- Up to 1024 inputs and 1024 outputs
- CCM2 Protocol
- 12 Mhz, 80C186 microprocessor
- 21 Kbytes battery-backed CMOS logic memory on board
- Supports optional expansion memory
- Two RS-422/RS-485 or RS-232 serial ports
- Soft configuration (No DIP switches or jumpers)
- Restart/Reset Pushbutton
- OK Status LED

Functions

The State Logic Processor Module (SLP) provides real time multi-tasking control for machine and process applications. It can also be programmed to perform computations, data acquisition, data communications and operator interface functions. The SLP is programmed using the English Control Language Programming System (ECLiPS) software package. It communicates with the PLC CPU over the backplane and can access user and system data. Many SLPs can be supported in a single IC697 PLC system and each SLP can support up to 1024 inputs and 1024 outputs.

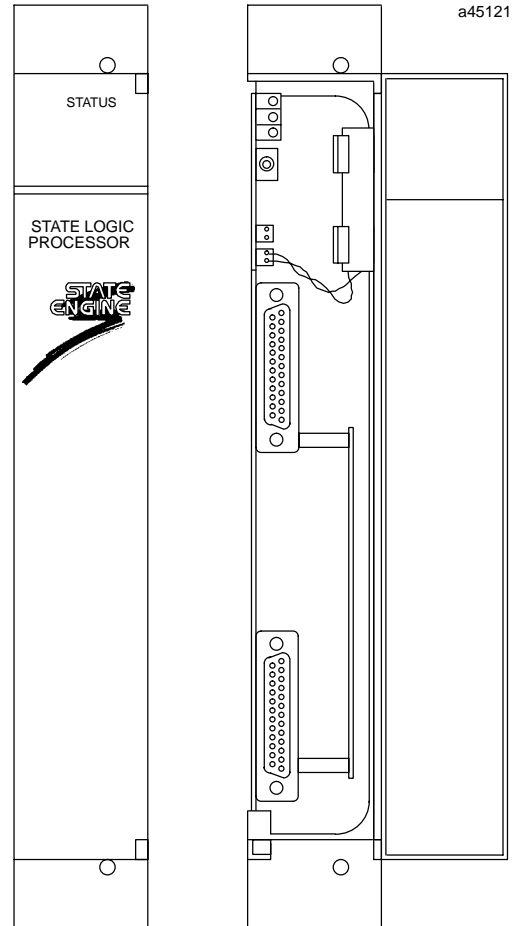

The PLC CPU and SLP modules together in the IC697 PLC provide a dual processor architecture which can be used in a wide variety of applications. The SLP provides total state logic control, including diagnostic and simulation capabilities, for those applications requiring reduced development and startup times. For those applications where both ladder logic and state logic programming is desired, the dual processor architecture allows a user to create both ladder logic and state logic application programs in any combination for efficient parallel processing solutions.

In IC697 PLC ladder logic control systems, the SLP module can be added to provide high level machine and process level diagnostics which can drastically reduce total system downtime. Also, the SLP module can provide machine or process simulation capabilities to IC697 PLC lad-

GFK-0734C
August 1997

State Logic Processor Module (SLP)

der logic control systems to help reduce debug and start-up times.

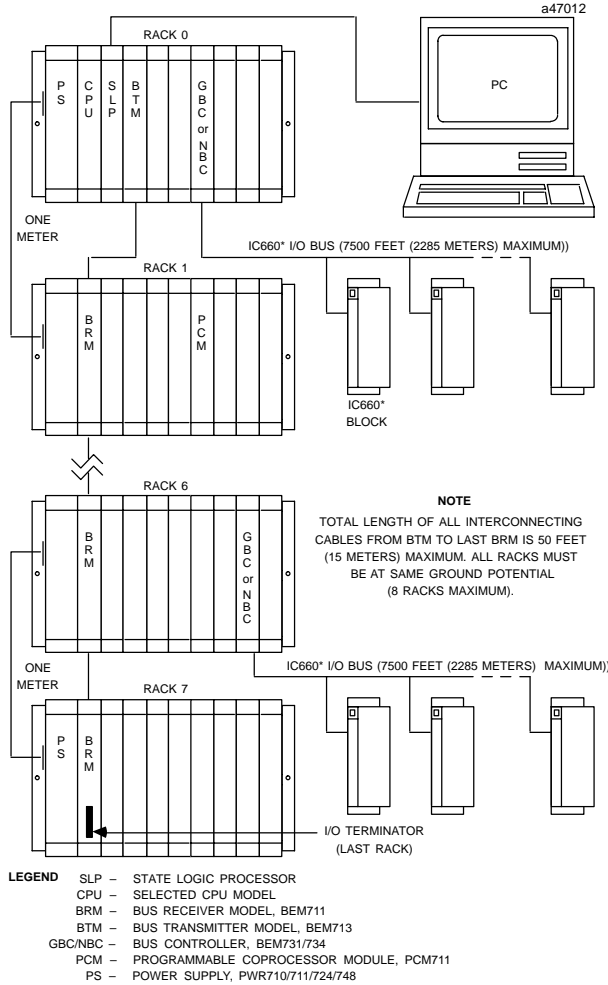

Figure 1. SLP Module in an IC697 PLC System Configuration

Installation

- Installation should not be attempted without referring to the *State Logic Processor User's Guide* (see reference 1).
- Make sure rack power is off.
- Install expansion memory if required.
- Connect the battery to either of the battery connectors on the module. (See figure 2)
- Install the SLP Module in the rack. (See figure 1)
- Turn on power.

The module should power up and blink the top LED, indicating that power up diagnostics are in progress. When the diagnostics have completed successfully the top LED stays on.

Expansion Memory

The SLP can operate with or without an expansion memory daughter board. The base memory on the SLP module has 21 Kbytes of user program memory space. The expansion memory daughter board permits expansion of the user program memory space by 64, 128, 256 or 512 Kbytes. The battery which supports this memory is located on the base SLP module housing as shown in figure 2.

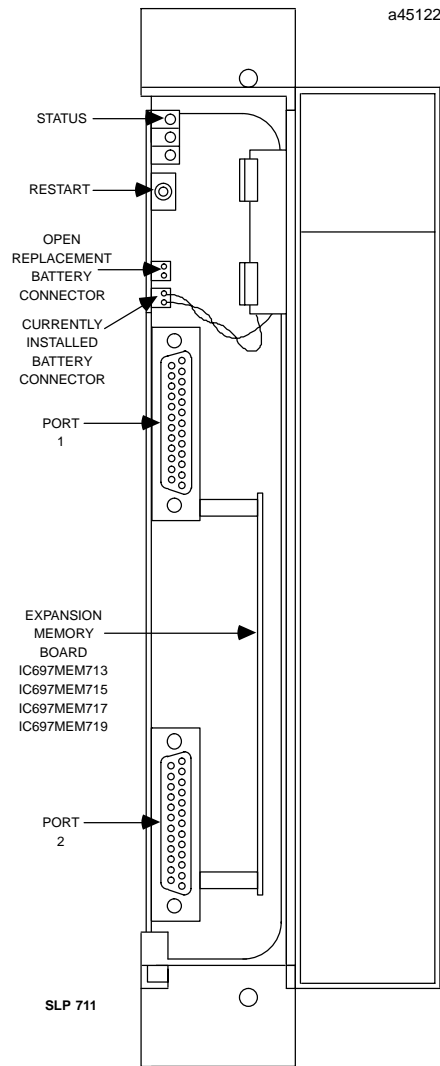

Figure 2. State Logic Processor Module, User Details
Programming and Configuration

There are no user DIP switches or jumpers on this module for configuration. However, the module must be configured into the overall PLC system using IC641

State Logic Processor Module (SLP)

GFK-0734C
August 1997

(MS-DOS®) configurator software (see reference 4). An IBM-compatible PC-XT or AT computer with the ECLiPS programming system software installed is connected to port 1, (top port) as shown in figure 3. The top port is the default programming port, but the SLP can also be configured to be programmed through port 2, the bottom port. The Default setting is 19,200 bps.

Both ports can be configured independently as RS-422/RS-485 or RS-232 serial ports for operation with a variety of serial devices such as operator interfaces, bar code readers, weigh scales, etc. One of the two ports can also be configured to communicate with the CCM2 protocol as a slave typically for use with operator interface terminals. Refer to the *State Logic Processor User's Guide* for details of operation.

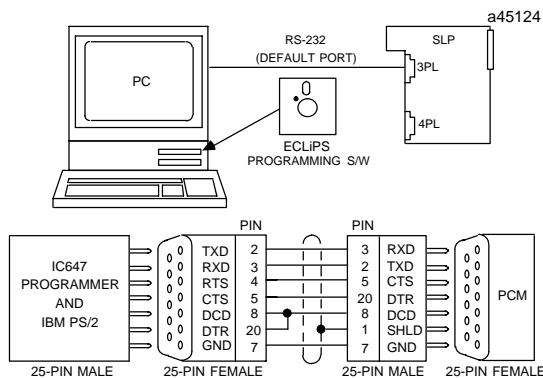

Figure 3. Development PC System Running ECLiPS and its Connection to SLP

Port 1 (3PL) and Port 2 (4PL)

Connectors 3PL and 4PL contain signals for both RS-232C and RS-422/RS-485 types of communication circuits. The pin-out for the RS-232C signals are per the RS-232C specification with an exception that pins not normally used for RS-232C are used for RS-422/RS-485 signals. Details are shown in tables 1 and 2.

Table 1. Port 1 or 2, RS-232C

PIN	FUNCTION	SIGNAL NAME	I/O
1	Shield	-	-
2	TransmittedData	TD	Output
3	ReceivedData	RD	Input
4	Request To Send	RTS	Output
5	Clear To Send	CTS	Input
7	Signal Ground	0V	-
8	Data Carrier Detect	DCD	Input
20	Data Terminal Ready	DTR	Output

Table 2. Port 1 or 2, RS-232/RS-485

PIN	FUNCTION	SIGNAL NAME	I/O
9	Send Data (A)	SD (A)	Output
10	Request To Send (A)	RTS (A)	Output
11	Clear To Send (A)	CTS (A)	Input
12	Termination for pin 13	-	-
13	Receive Data (A)	RD (A)	Input
21	Send Data (B)	SD (B)	Output
22	Request To Send (B)	RTS (B)	Output
23	Clear To Send (B)	CTS (B)	Input
24	Termination for pin 23	-	-
25	Receive Data (B)	RD (B)	Input

Status Indication

Three Status LEDs exist on the SLP module as shown in figure 2. The top LED indicates the condition of the module and is ON during normal operation. The bottom two LEDs are not used and will always be off.

Controls

One pushbutton is provided. Push and hold the pushbutton for less than 5 seconds will simply restart the user application program if it was configured to *auto-run* at power up. Push and hold for more than 5 seconds and the module is reinitialized and the user application program must be reloaded.

© MS-DOS is a trademark of Microsoft Corporation.

GFK-0734C
August 1997

State Logic Processor Module (SLP)

Battery

A lithium battery (IC697ACC701) is installed as shown in figure 2. This battery maintains user memory when power is removed. Be sure to install a new battery be-

fore removing the old battery (two connectors are provided). Indication of a low battery is provided through the ECLiPS programming system software (see reference 2) and IC641 programming software (see reference 4).

Table 3. References

Reference	Title
1	PLC State Logic Processor User's Guide
2	PLC ECLiPS User's Manual
3	PLC OnTOP User's Guide
4	Programming Software User's Manual
5	Programmable Logic Controller Reference Manual
6	Programmable Controller Installation Manual

Table 4. Hardware Specifications for AD697SLP711 †

Battery	
Shelf Life	10 years at 20°C (68°F)
Memory Retention	6 months nominal without applied power
Serial Ports	RS-232/RS-422/RS-485 compatible
Current required from 5 VDC backplane bus	1.0 amp
VME	System designed to support the VME standard C.1

† Refer to GFK-0867B, or later for product standards and general specifications. For installations requiring compliance to more stringent requirements (for example, FCC or European Union Directives), refer to *Installation Requirements for Conformance to Standards*.

State Logic Processor Module (SLP)

GFK-0734C
August 1997

Table 5. Table 5. Firmware Specifications

Tasks	256
States per task	255
Integer Variables (range -32768 to +32767)	1000
Floating Point Variables (range $\pm 1.175494\text{E}-38$ to $\pm 3.402823\text{E}+38$) 32-bit IEEE format	1000
String Variables	100
String Variable Size	80 characters
Character Variables	64
PID Loops	10
Number of Timers	unlimited
Timer Resolution	1/100 second
Maximum Total Number of States	600
Available Program Memory	21 Kbytes
User Reference Type and Quantity Available	
%I	1024
%Q	1024
%AI	256
%AQ	256
%T	256
%M	2048
%G	1280
%S	128
%SA	128
%SB	128
%SC	128
%R	2048

Table 6. Ordering Information

Description of Item	Catalog Number
State Logic Processor Module (21 Kbytes) for IC697 PLC Systems	AD697SLP711
64 Kbyte CMOS Expansion Memory	IC697MEM713
128 Kbyte CMOS Expansion Memory	IC697MEM715
256 Kbyte CMOS Expansion Memory	IC697MEM717
512 Kbyte CMOS Expansion Memory	IC697MEM719
Lithium Battery	IC697ACC701

Bus Expansion Modules

IC697BEM731/734

GFK-0165G
August 1997

Bus Controller Module

Features

- Thirty Drops per channel
- IC66* (IC660 or IC661) I/O Diagnostics
- Redundant blocks, cables and CPUs supported
- Global Communications
- Hand Held Monitor Port
- IC66* LAN Communications
- Soft configuration by CPU
- Operation augmented by IC697 PLC Alarm Processor function

Functions

The IC66* Bus Controller (GBC/NBC) is available as a single channel controller. It occupies a single IC66* PLC slot. The bus controller is configured by the MS-DOS® or Windows® programming software configurator function. IC66* Input/Output blocks are scanned asynchronously by the bus controller and I/O data is transferred to the CPU once per scan over the backplane of the IC697 PLC rack.

The bus controller also supports directed communications initiated by a PLC CPU Communication Service Request. In addition, it may be configured to perform global communications.

Faults reported by the bus controller are managed by the PLC Alarm Processor Function which time stamps and queues faults in a table.

For applications requiring peer to peer information transfer, the Bus Controller can serve as a communications node linking other devices (Bus Controllers, PCIMs, and other IC66* devices) via the IC66* bus. Such a network can provide communications between multiple PLCs and host computers.

These communications include transmitting global data from one CPU to another. The global data area is identified by MS-DOS or Windows configuration. After initialization, the specified data area is transferred between devices automatically and repetitively.

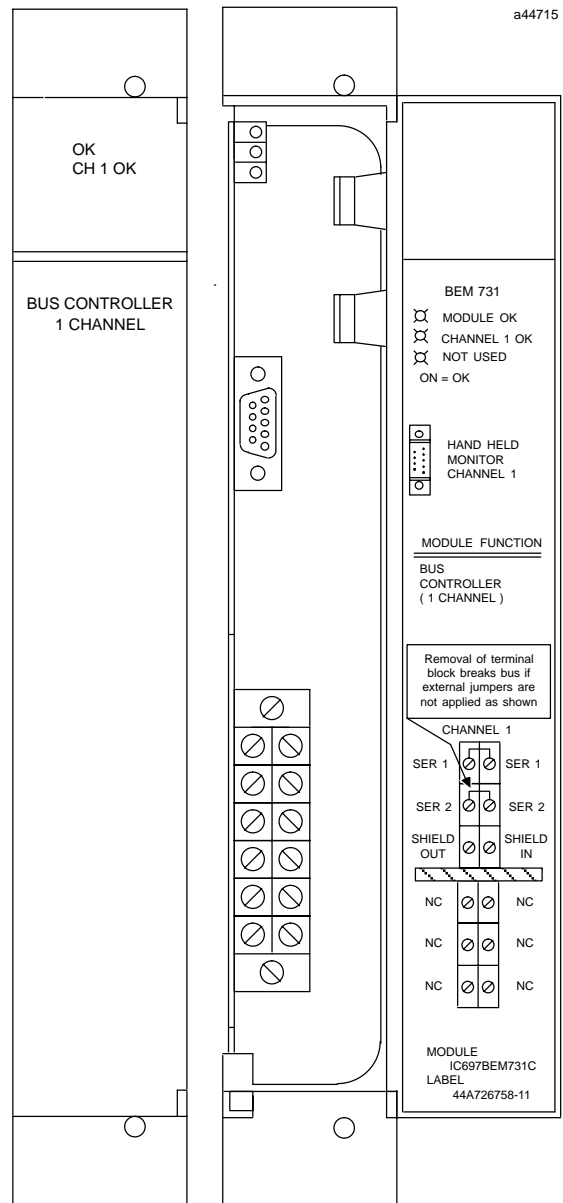

In addition, messages called Datagrams can be transmitted in response to individual commands in the ladder logic. Datagrams can be sent from one device on the network to another, or broadcast to all devices on the bus. IC66* LAN communications are supported throughout the IC69* PLC family.

© MS-DOS and Windows are registered trademarks of Microsoft Corporation.

GFK-0165G
August 1997

Bus Controller Module

Installation

- Installation should not be attempted without referring to the applicable *PLC Installation Manual*.
- Make sure rack power is off.
- Install in rack. (See figure 1)
- Turn on power.

The module should power up and blink the top LED for about 5 seconds. When the diagnostics have completed successfully the top LED stays. The middle LED is turned ON when a valid configuration for the module has been received from the CPU, and the IC66* I/O bus operation has been verified. The bottom LED is OFF under all conditions.

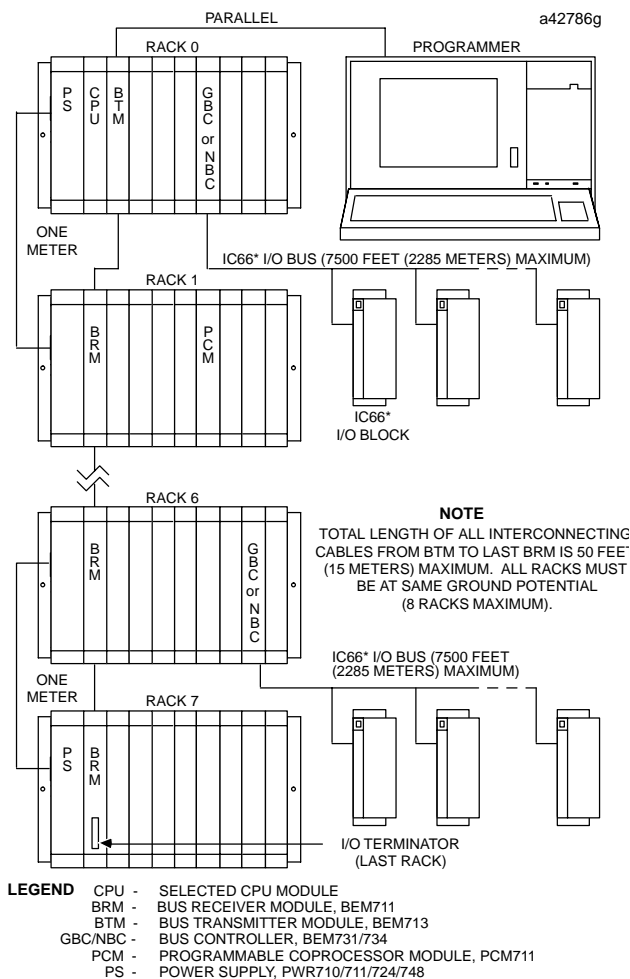

Figure 1. Typical PLC System Configuration

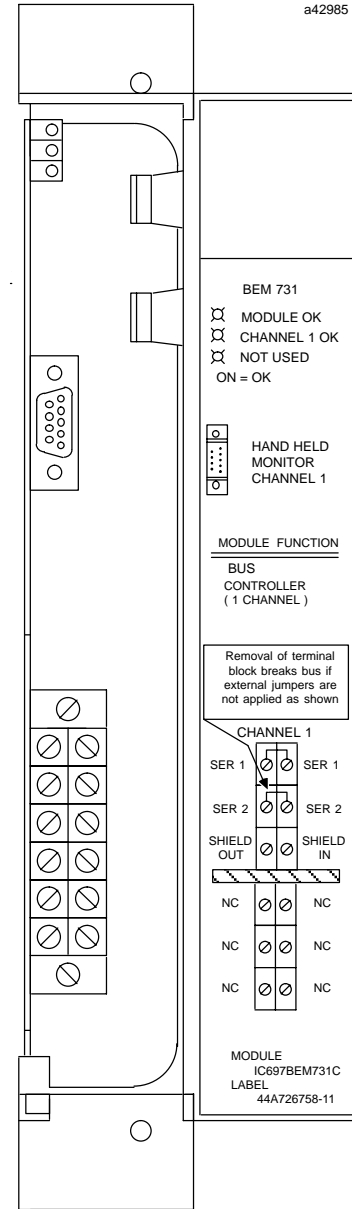

Figure 2. IC66 * Bus Controller Module User Details

Note

Refer to Figure 1, Bus Transmitter Module version IC697BEM713A must be installed to the right of the GBC/NBC or any other IC697 I/O modules. BTM version IC697BEM713B can be installed as shown in the figure (next to the CPU).

Bus Controller Module

GFK-0165G
August 1997

Removing a Module

The instructions below should be followed when removing a module from its slot in a rack.

- Grasp the board firmly at the top and bottom of the board cover with your thumbs on the front of the cover and your fingers on the plastic clips on the back of the cover.
- Squeeze the rack clips on the back of the cover with your fingers to disengage the clip from the rack rail and pull the board firmly to remove it from the backplane connector.
- Slide the board along the card guide and remove it from the rack.

Bus Controller Operation

Each IC66* I/O serial bus conveys data by passing a "token" among the devices on the bus.

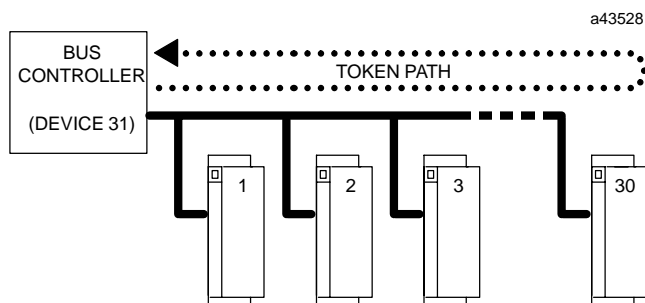

Figure 3. Bus Scan Cycle

During the bus scan, the Bus Controller:

- Receives all inputs from the I/O blocks.
- Receives any faults and sets diagnostic status references for use of the PLC CPU when it is accessed once each scan.

- Updates all outputs on the I/O blocks.
- Sends any command received from the CPU (for example, Clear Circuit Fault) to the appropriate device.

The IC66* I/O bus scan is independent of the IC697 PLC CPU sweep. The PLC CPU sweep is shown below.

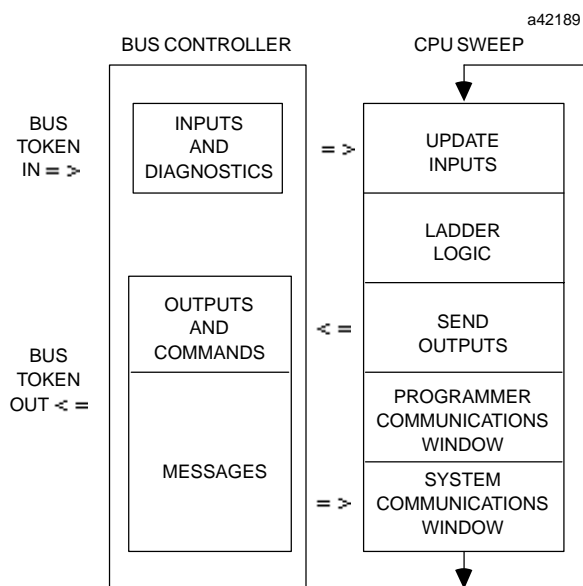

Figure 4. CPU Sweep

During the I/O service portions of the CPU sweep, the Bus Controller:

- Makes available to the CPU all discrete inputs and analog inputs.
- Receives current outputs and new commands from the CPU.
- Reports its status and that of the serial bus.

Communications Window

The Bus Controller can communicate with the CPU via the Communications window using these commands:

- 1 Pulse Test Outputs
- 2 ReadConfiguration
- 3 WriteConfiguration
- 4 ReadDiagnostics
- 5 Clear Circuit Fault
- 6 Clear All Circuit Faults
- 7 AssignMonitor
- 8 Enable/DisableOutputsGlobal
- 9 Enable/DisableData
- 10 Switch BSM
- 11 ReadDevice
- 12 Write Device
- 13 DequeueDatagram
- 14 SendDatagram
- 15 RequestDatagramReply

labeled 44A730116-G02 for those cables with 75 ohm impedance. Also supplied with each board are two prefabricated plugs for termination of both 75 ohm and 150 ohm cables at the last IC66* I/O block on the Serial bus. These plugs are labeled 44A713909-004 for 75 ohm termination and 44A713909-003 for 150 ohm termination.

Using shielded, twisted pair cable, create a serial bus connecting the Bus controller, I/O blocks, and other permanently-installed devices as shown in figure 5.

Caution

All cable used for one serial bus must be of the same type, or the bus will not work.

Other busses connected to the same CPU may use different types of cable (unless joined by a Bus Switching Module, as shown in figure 6). Cable specifications are found in Table 2 . For applications using Belden 9182 type cable, prefabricated cables are available in 15 inch and 36 inch lengths for interconnection of IC66* I/O blocks (not compatible with IC697 PLC IC66* Bus Controllers). One 75 ohm and one 150 ohm plug is included with each IC66* Bus Controller. See the Ordering Information on page 7 .

Hand Held Monitor Port (1PL)

Port 1 PL is for the Hand Held Monitor Connection.

IC66* Bus Field Terminal Connections (3PL)

Connector 3 PL contains the necessary connection points for the IC66* bus.

The serial bus must be terminated at each end by its characteristic impedance. If the Bus Controller is at the end of the bus, select the correct impedance for the cable length and type, as shown in table 2.

Included with each board are two small packages containing two resistors each. Use the resistors in the package labeled 44A730116-G01 for those cables with 150 ohm impedance. Use the resistors in the package

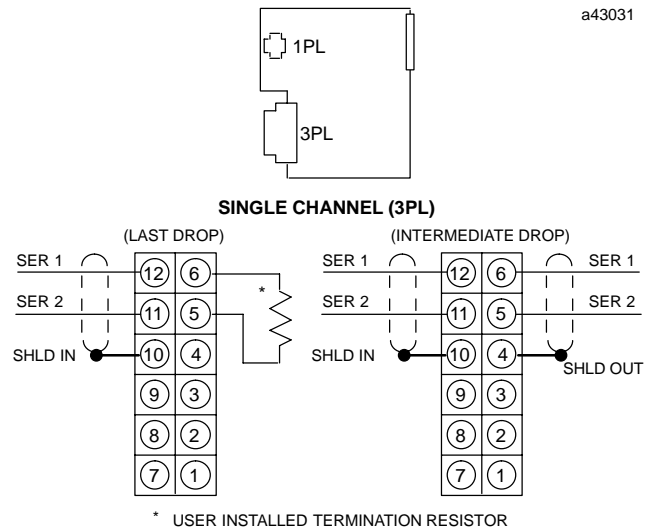

Figure 5. Wiring Diagram

Bus Controller Module

GFK-0165G
August 1997

Configuration

The module powers up with no assumed baud rate or serial bus address. The MS-DOS or Windows programming software configurator function defaults these to 153.6K baud standard and serial bus address of 31. After a valid configuration has been stored to the system, the PLC CPU transfers the configured baud rate and serial bus address to the module at the conclusion of the store and each time the Bus Controller is power cycled.

Setting the Bus Controller Baud Rate

The default baud rate is set at 153.6 Kbaud (standard). This rate supports an IC66* I/O bus up to 2000 feet in length. For greater distances the baud rate may be selected from the table below to support an IC66* I/O bus up to 7500 feet in length. (153.6 Kbaud Extended has additional delays between messages to support a longer bus length.)

Caution

Select the same baud rate for the Bus Controller as that used for other devices on the bus. *The bus will not operate unless all devices are set to the same baud rate.*

Table 1. IC66* Bus Length vs. Baud Rate

Baud Rate (K baud)	Maximum IC66* I/O Bus Length (Feet)
153.6 Standard	2000
153.6 Extended	3500
76.8	4500
38.4	7500

Other baud rates may be configured with the MS-DOS or Windows configuration software.

Setting the Serial Bus Address

The default serial bus address is 31. Other serial bus addresses may be assigned with the MS-DOS or Windows programming software configuration function.

Dual Serial Busses with a BSM

For some applications, a dual serial bus may be used to provide a backup communications path. Bus Switching Modules (BSMs) connect bus stubs containing a few IC66* I/O blocks with two serial busses, each with its own Bus Controller(s) or PCIM module(s). Blocks on a stub are connected using short lengths of non-terminated cable.

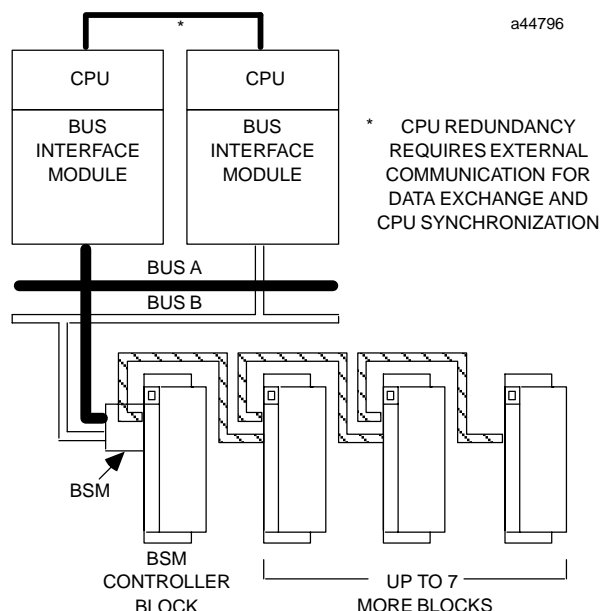

Figure 6. Dual Bus System

See Reference 4 for other redundant configurations.

Monitoring Bus Status

To display serial bus status, set the Hand Held Monitor to Monitor mode and attach to PL1. From the Block/Bus Status screen, press F4 (Bus).

```

S E R I A L B U S S T A T S
A C T V D E V I C E S =
S C A N T I M E =           mS
    
```

In a dual bus system, cable length and block placement should be planned well. Before installing blocks or cabling for a system using BSMs, read the Bus Switching Module Data Sheet (GFK-0072).

Dual busses are supported by two busses in different CPUs. The IC697 PLC will not support redundant busses in separate bus controllers in the same CPU.

GFK-0165G
August 1997

Bus Controller Module

Table 2. IC66* Bus Cable Specifications

Cable # & Make	Outer Diameter	Terminating Re- sistor -10% to +20% .5 Watt	Installation	Number of Conductors /AWG	Dielectric Voltage Rating	Ambient Temp. Rating	Maximum Length Cable Run, feet/meters at baud rate			
							153.6s	153.6e	76.8	38.4
(B)9182 (A)9B23 (C)4596	.350in. 8.89mm	150 ohms	In conduit	2 / #22 (.329mm ²)	30v	60°C	2000ft 606m	3500ft 1061m	4500ft 1364m	7500ft 2283m*
(B)89128	.322in 8.18mm	150 ohms	In plenum Noconduit	2 / #22 (.329mm ²)	150v	200°C	2000ft 606m	3500ft 1061m	4500ft 1364m	7500ft 2283m*
(B)	.270in 6.86mm	120 ohms	Double Shields	2 / #24 (.199mm ²)	30v	80°C	1000ft 303m	1500ft 455m	2500ft 758m	3500ft 1061m*
(B)9207	.330in 8.38mm	100 ohms	In conduit	2 / #20 (.519mm ²)	300v	80°C	1500ft 455m	2500ft 758m	3500ft 1061m	6000ft 1818m*
(B)89207 (A)4794	.282in 7.16mm	100 ohms	In plenum Noconduit	2 / #20 (.519mm ²)	150v	200°C	1500ft 455m	2500ft 758m	3500ft 1061m	6000ft 1818m*
(B)9815	.330in 8.38mm	100 ohms	Direct burial	2 / #20 (.519mm ²)			1500ft 455m	2500ft 758m	3500ft 1061m	6000ft 1818m*
(B)9855	.315in 8.00mm	100 ohms	In conduit	4 (2 pair) #22 (.329 mm ²)	150v	60°C	1200ft 364m	1700ft 516m	3000ft 909m	4500ft 1364m*
(B)89696 (B)89855	.274in 6.96mm	100 ohms	In plenum No con- duit fire re- sist	4 (2 pair) #22 (.329 mm ²)	150v	200°C	1200ft 364m	1700ft 516m	3000ft 909m	4500ft 1364m*
(B)9463 (A)9814	.243in 6.17mm	75ohms	In conduit	2 / #20 (.519mm ²)	150v	60°C	800ft 242m	1500ft 455m	2500ft 758m	3500ft 1061m
(B)9302	.244in 6.20mm	75 ohms	In conduit	4 (2 pair) #22 (.329 mm ²)	300v	80°C	200ft 30m	500ft 152m	1200ft 333m	2500ft 758m

Notes: A = Alpha, B = Belden, C = Consolidated
• Limited to 16 taps at 38.4 K baud.

Table 3. References

Reference	Title
1	ProgrammingSoftware User's Manual
2	ProgrammableControllerReferenceManual
3	ProgrammableControllerInstallationManual
4	Bus Controller User's Manual

Bus Controller Module

GFK-0165G
August 1997

Table 4. Specifications for IC697BEM731/734 †

Current required from 5V Bus VME	1.3 amps System designed to support the VME standard C.1
-------------------------------------	---

† Refer to GFK-0867B, or later for product standards and general specifications. For installations requiring compliance to more stringent requirements (for example, FCC or European Union Directives), refer to *Installation Requirements for Conformance to Standards*.

Table 5. Ordering Information

Description	Catalog Number
IC660/IC66 Bus Controller	IC697BEM731 IC697BEM734
Communications Cable (Belden 9182 type) 15 inch, qty. 3 36 inch, qty. 1	IC660BLC001 IC660BLC003
Bus Terminator Plugs 150 ohm, qty. 4 75 ohm, qty. 4	IC660BLM506 IC660BLM508

Note: For Conformal Coat option, or Low Temperature Testing option please consult the factory for price and availability.

Bus Expansion Modules

IC697BEM742, IC697BEM744

GFK-1002E
January 1998

FIP Bus Controller

Features

- Interfaces FIP or World FIP I/O serial bus to IC697 PLC
- Two versions available for standard IC697 racks: IC697BEM742 and IC697BEM744 - both have 2M of RAM and 2M of Flash memory
- Data rate for IC697BEM742 is 1 Mbit/second, IC697BEM744 is 2.5 Mbits/second
- Four FIP Bus Controllers per PLC system
- Two FIP bus channels provide redundant bus capability
- RS-485 serial port attaches to PC for easy in-system firmware upgrade (no PROMS to change)
- Pushbutton for resetting Bus Controller and enabling Bus Controller to accept upgrades
- FIP bus faults managed by PLC Alarm processor Function
- Six status LEDs
- Software configuration (no DIP switches or jumpers to set) using Windows® programming software configuration function running on Windows® 95 or Windows NT®

Functions

A FIP Bus Controller (FBC) is a two channel bus controller that occupies a single slot in an IC697 PLC standard or VME Integrator rack. I/O devices on the FIP bus are scanned asynchronously by the bus controller and I/O data is transferred to the CPU once per scan.

Up to 31 Bus Controllers, of any kind, can be included in an IC697 PLC system. Of the 31 Bus Controllers, a maximum of four can be FIP Bus Controllers.

A FIP bus may serve:

- **IC697 and IC693 PLCs** interfaced to the bus by FIP Bus Controllers.
- **Remote Drops**, IC693 I/O racks that are interfaced to the bus through Remote I/O Scanner Modules. Each remote drop can include any mix of discrete and analog I/O modules.
- **Field Control Stations**, Field Control I/O modules that are interfaced to the bus via a FIP Bus Interface Unit (BIU).

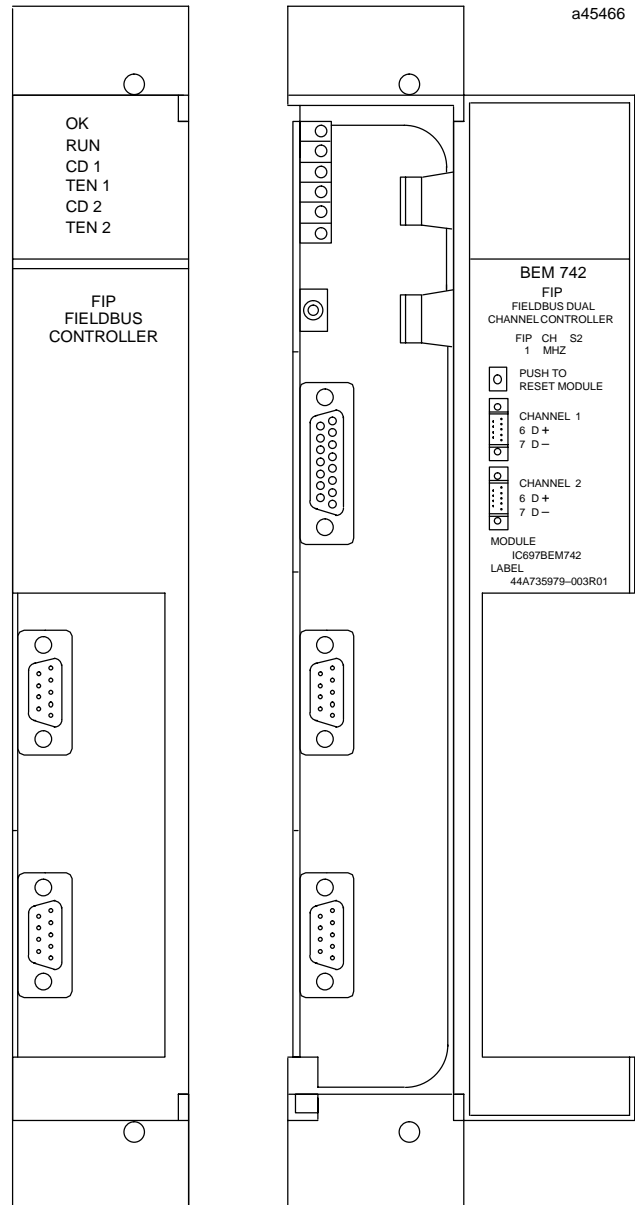

* BEM742 shown; BEM744 looks the same except for door label

- **Generic Devices**, such as general-purpose computers that are interfaced to the bus via a 3rd Party FIP Module.

A FIP bus is used primarily for I/O control. It is also used to store configuration data to remote devices and to report faults.

© MS-DOS, Windows, Windows 95, and Windows NT are registered trademarks of Microsoft Corporation.

GFK-1002E
January 1998

FIP Bus Controller

Location in a System

A FIP Bus Controller module can be installed in any I/O slot in the CPU rack of an IC697 PLC system. The following figure shows a typical installation with a FIP Bus Controller connected to an IC693 Remote I/O Scanner

which allows IC693 I/O modules to be on the FIP Bus. The IC693 Remote I/O Scanner and the modules it serves are referred to as a FIP I/O Nest. For detailed information on the IC693 Remote I/O Scanner, refer to the *Remote I/O Scanner User's Manual*.

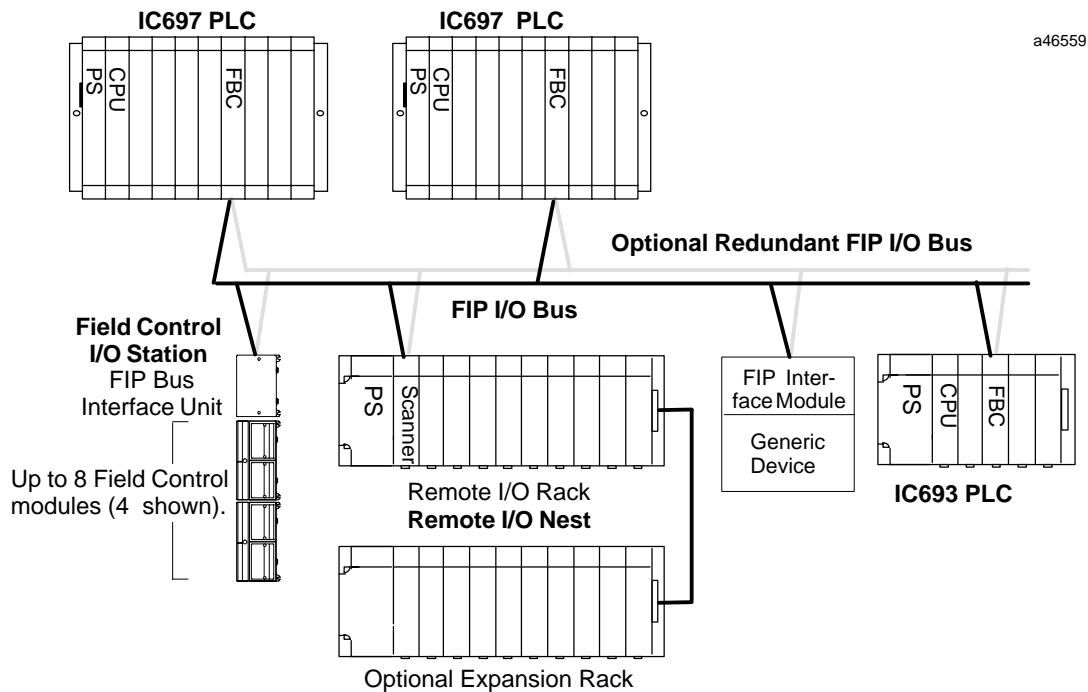

Figure 1. Example of FIP Bus Controller In a System

Installing a FIP Bus Controller

- Installation should not be attempted without referring to the applicable *Programmable Controller Installation Manual* and the *FIP Bus Controller User's Manual*.
- **Be sure that rack is powered down.**
- Position the FIP Bus Controller at its intended slot location in the rack.
- Push the FIP Bus Controller into the card guide until it is aligned with the connector on the rack backplane.
- While pressing the upper and lower flanges on the left of the module, push it into the connector until it clicks onto the rack rails. Be sure that the board has seated properly in the connector.
- Bus connections to the connectors on the front of the module can now be made.

FIP Bus Controller

GFK-1002E
January 1998

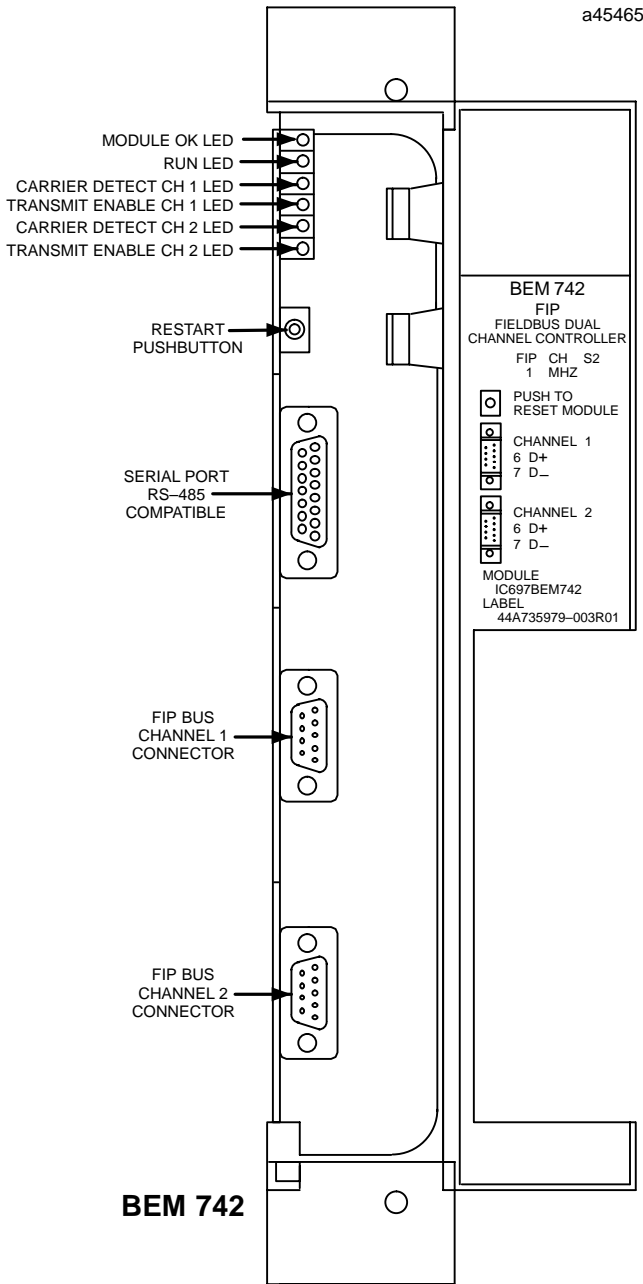

* BEM742 is shown; BEM744 looks the same except for door label

Figure 2. FIP Bus Controller Module - User Features

FIP Bus Controller Description

Following is a basic description of the module features (refer to Figure 2 for location of hardware features).

Status LEDs

The six LEDs located on the front of the FIP Bus Controller display module status and communications activity.

The top two LEDs indicate module health. The bottom four LEDs indicate communications activity on the FIP bus. Two LEDs are dedicated to each of the two FIP channels.

MODULE OK

Shows the status of the FIP Bus Controller. This LED blinks during power-up diagnostics and should remain on as long as power is applied to the Bus Controller.

RUN

Shows the operational status of the FIP Bus Controller. This LED turns ON when the module is acting as the Bus Arbiter for the FIP network.

CARRIERDETECT CH 1

This LED is ON when detecting a carrier signal on the FIP bus attached to channel 1.

TRANSMIT ENABLE CH 1

This red LED is ON when the FIP Bus Controller transmits data on the FIP bus attached to channel 1.

CARRIERDETECT CH 2

This LED is ON when detecting a carrier signal on the FIP bus attached to channel 2.

TRANSMIT ENABLE CH 2

This red LED is ON when the FIP Bus Controller transmits data on the FIP bus attached to channel 2.

Pushbutton

A pushbutton located directly below the LEDs is provided as a means to enable the Bus Controller to accept an upgrade of its operating firmware. It is also used to locally reset the Bus Controller in the event of a watchdog timeout.

GFK-1002E
January 1998

FIP Bus Controller

Serial Connector

The 15-pin Serial Connector on the FIP Bus Controller provides for attachment of a PC computer to perform an upgrade of the operating firmware of the Bus Controller. The port supports the RS-485 electrical standard.

Table 1. RS-485 Serial Port Pin Assignments

Pin Number	SignalName	Pin Number	SignalName
1	Shield Ground	9	Termination Resistor*
2	no connection	10	RXD-
3	no connection	11	RXD+
4	ATTACH	12	TD-
5	+5V (5 Volts DC)	13	TD+
6	RTS-	14	RTS+
7	0V (DC Ground)	15	CTS+
8	CTS+	Shell	Board Frame Ground

* A 120 ohm resistor is capacitively coupled to the board frame ground.

FIP Bus Connectors (Channel 1 and 2)

Two 9-pin connectors on the FIP Bus Controller provide for attachment of one or two FIP busses. The top 9-pin connector is for FIP bus *Channel 1* and the bottom 9-pin connector is for FIP bus *Channel 2*. Since signals on both busses are identical, the two busses provide a redundant bus capability.

Table 2. FIP Bus Connector Pin Assignments

Pin Number	Signal Name	Pin Number	Signal name
1	no connection	6	D+
2	no connection	7	D-
3	no connection	8	no connection
4	no connection	9	no connection
5	no connection	Shell	Signal Ground*

* The connector shell is capacitively coupled to the board frame ground.

Note that if cables with plastic shell connectors are not connected to both ports, the provided plastic connector cover and nylon screws should be used to cover the exposed metal connector of the FIP communication port not used.

The FIP Bus

The FIP bus is a shielded twisted-pair wire. Proper cable selection is critical to successful operation of the system. Suitable cable types are listed in the *FIP Bus Controller User's Manual*.

Conservative wiring practices, as well as national and local codes, require physical separation between control circuits and power distribution or motor power. Refer to sections 430 and 725 of the National Electric Code.

Table 3. FIP Bus Characteristics

Bus Type	Single twisted pair plus shield. Fiber optics cable and modems can also be used.
BaudRate	BEM742: 1.0 Mbaud BEM744: 2.5 Mbaud
MaximumBusLength	1000 meters per section (for 1.0 Mbaud.); 500 meters per section for 2.5 Mbaud 4000 meters per network for 1.0 Mbaud; 2000 meters per network for 2.5 Mbaud. 3 repeaters per network.
MaximumNumberof Devices	32 devices per section
DataEncoding	Manchester II Encoding

Connecting the Serial Bus

For information about bus selection and installation, please refer to the *FIP Bus Controller User's Manual*.

Connect the bus cable to the connector(s) on the front of the Bus Controller. When installed in a single media or simplex configuration, either connector can be used. When installed in a dual media or redundant configuration, both the Channel 1 and 2 connectors must be used. Both connectors accept a standard 9-pin D-type male connector.

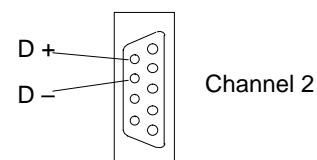
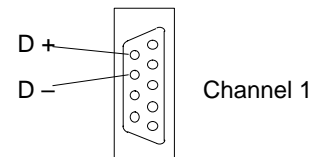

FIP Bus Controller

GFK-1002E
January 1998

Bus Controller Operation

The Bus Controller handles all data transfer between the PLC and the devices on its bus. In order to do this, the Bus Controller must interface two completely separate and asynchronous activities:

- A. The *FIP bus scan*, a cycle of communications between the devices on a bus (including the Bus Controller itself).
- B. The *CPU sweep*, the cycle of actions that includes communications between the CPU and the Bus Controller.

The Bus Controller manages data transfer between the bus and the CPU by maintaining two separate on-board RAM memories. One interfaces with the bus and the other interfaces with the CPU. The Bus Controller automatically transfers data between these two memories, making data available to the bus or to the CPU when it is needed.

The FIP Bus Scan

A FIP bus scan (also referred to as a macro-cycle) consists of a fixed set of operations that are repeated as long as the RUN LED of the FIP Bus Controller is ON. The length of the macro-cycle, once configured never varies. Therefore, the bus scan is fixed.

During the bus scan, the FIP Bus Controller:

- Requests all produced data from all devices to be broadcast on the FIP network, at the predefined period
- Independently tests the presence of any remote devices (optional)

- Allows the broadcast of any aperiodic I/O data by any 3rd Party device but only for the maximum time configured (optional)
- Allows the transmission of any messages by any device but only for the maximum time configured (optional)
- Receives a diagnostic message from each IC6** device

Diagnostics

FIP devices on the bus will automatically report faults, alarms and certain other predefined conditions to the PLC.

The Bus Controller stores any diagnostic messages it receives. They are read automatically by the IC697 CPU. Faults can then be displayed in the fault table using the Windows programming software and cleared from the programmer. Detailed information on faults on the FIP bus can be found in Chapter 5 of the *FIP Bus Controller User's Manual*.

In addition to the built-in diagnostics capabilities of FIP devices, the Windows programming software application program can make use of additional diagnostics mechanisms provided by the IC697 PLC.

- System Status References that have been defined for FIP use.
- Fault and No Fault contacts that can be used to detect fault and lack of fault conditions.
- Alarm contacts that can be used to indicate when an analog value has reached an assigned alarm limit.

Table 4. Applicable Manuals

Reference	Title
1	IC697 FIP Bus Controller User's Manual
2	IC693 FIP Remote I/O Scanner User's Manual
3	IC670 FIP Bus Interface Unit User's Manual
4	Programmable Controller Installation Manual
5	Programming Software User's Manual
6	Programmable Controller Reference Manual

Table 5. Specifications for IC697BEM742/BEM744 †

Operating Conditions: Atmospheric Pressure	80 kPa to 108 kPa
Storage and Transport Characteristics Atmospheric Pressure Free Fall	66 kPa to 108 kPa 250mm (9.84 inches)
General Specifications Module Operating Voltage Module Current Drain Memory for IC697BEM742 Memory for IC697BEM744 LEDs Data Rate for IC697BEM742 Data Rate for IC697BEM744 Protocol VME	5 VDC (from backplane) 1.4 Amps, typical 2 Megabytes of RAM, 2 Megabytes of Flash 2 Megabytes of RAM, 2 Megabytes of Flash OK Module OK RUN Bus Arbiter Status CD 1 Carrier Detect Channel 1 TEN 1 Transmit Enable Channel 1, CD 2 Carrier Detect Channel 2 TEN 2 Transmit Enable Channel 2 1Mbit/second 2.5Mbits/second FIP/World FIP System designed to support the VME standard C.1

† Refer to GFK-0867B, or later for product standards and general specifications. For installations requiring compliance to more stringent requirements (for example, FCC or European Union Directives), refer to *Installation Requirements for Conformance to Standards*.

Table 6. Ordering Information

Description	Catalog Number
FIP Bus Controller Module, 2 Mbytes of RAM and 2 Mbytes of Flash memory (Data Rate: 1 Mbit/second)	IC697BEM742
FIP Bus Controller Module, 2 Mbytes of RAM and 2 Mbytes of Flash memory (Data Rate: 2.5 Mbit/second)	IC697BEM744

Note: For Conformal Coat option, or Low Temperature Testing option please consult the factory for price and availability.

Bus Expansion Modules

IC697BEM713

GFK-0161H
August 1997

Bus Transmitter Module

Features

- High Performance Parallel Programmer Interface
- Bus Expansion Interface
- Supports up to 7 Expansion racks
- Three LED indicators provide module, programmer port, and expansion port status
- No DIP switches to set, easy software configuration into PLC system

Functions

The Bus Transmitter Module (BTM) permits expansion from the main CPU rack when more modules are required in a system than can be contained in the CPU rack. The BTM allows expansion from the CPU rack to a maximum of 7 additional IC697 PLC racks. It also provides a high performance parallel interface to the programming device.

The module occupies a single slot and has two connectors. The top one is for attachment to the programming device. The bottom one is for a daisy-chained arrangement through Bus Receiver Modules to expansion racks.

Three green LEDs provide status indication of each port and module status.

The BTM must be configured into the IC697 PLC system using the MS-DOS® or Windows® programming software configuration function.

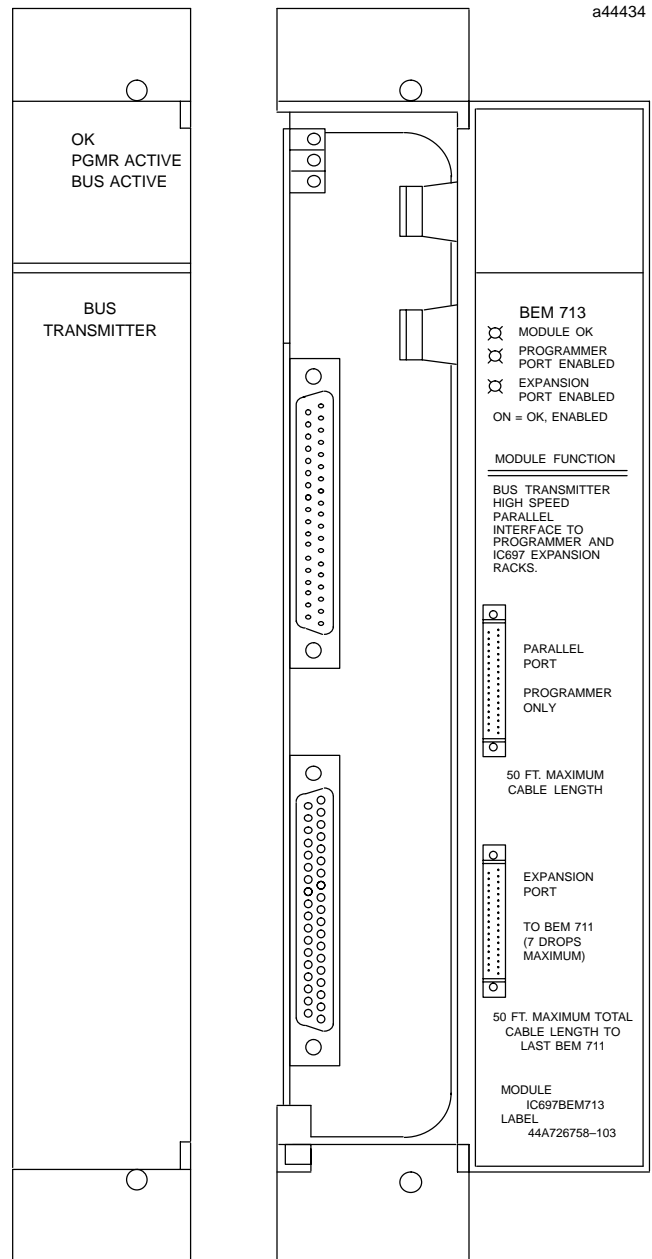

© MS-DOS and Windows are registered trademarks of Microsoft Corporation.

GFK-0161H
August 1997

Bus Transmitter Module

Installation

- Installation should not be attempted without referring to the applicable *Programmer Controller Installation Manual* (See reference 3).
- Make sure rack power is off.
- Install in any slot (except slot 1) in the main CPU rack.
- Turn on power.

Note

BTM Version IC697BEM713A must be installed to the right of any IC697 interrupt source modules (GBC, PCM, Integral Inputs). BTM Version IC697BEM713B and later versions can be installed as shown in Figure 1.

Module Mechanical Keying

This module includes a mechanical key that prevents inadvertent substitution of one module type for another in a given slot. The key fits a uniquely shaped area on the board below the connector. The key is included with each module.

When the module is first installed, the key latches onto the backplane center rail. When the module is extracted, the key remains in the center rail, configuring the slot to accept only identical module types.

If it is necessary to change the module location in the rack after the key has been latched onto the center rail of the rack, the key can be removed by pushing it upward to unhook the latch while pulling it off the rail. It may then be reinserted onto the module and the module inserted into the rack in the desired location. Note: Only the power supply can be placed in the leftmost rack position.

Programmer Connection, Parallel

For a parallel interface (MS-DOS programmer only), the programmer is connected to the top connector of the BTM with cable IC647CBL703 as shown in Figure 2.

Expansion Rack Attachment

The BTM is attached to BRMs in expansion racks with cable IC600WDFxxx (where xxx is length in feet) as shown in Figure 1.

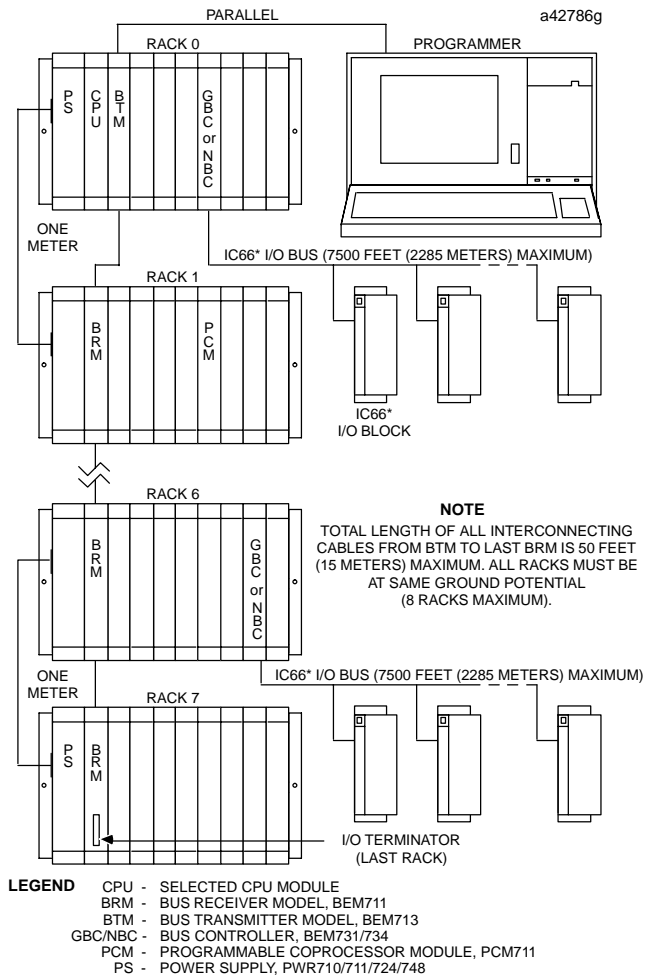

Figure 1. Typical PLC System Configuration

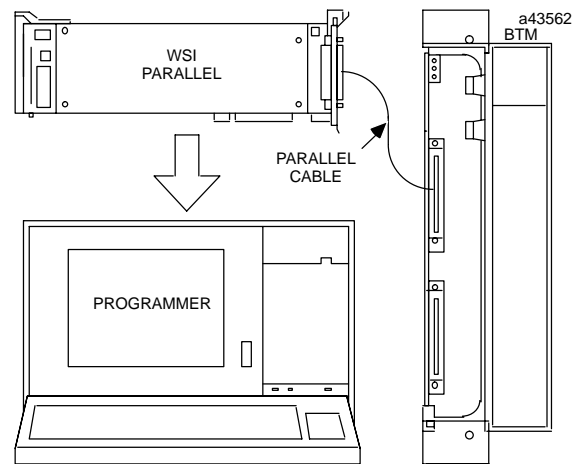

Figure 2. Parallel Programmer Attachment to BTM

Bus Transmitter Module

GFK-0161H
August 1997

Status Indications

Three green LEDs at top of module provide module status information as described below.

The top LED (MODULE OK) LED is *ON* when the CPU software completes its power-up configuration of the BTM, and has polled (or attempted to poll) each expansion rack in the system. It is *OFF* when any of these conditions are not met.

The middle LED (Programmer Port Enabled) is the Programmer Port Active LED. This LED is either *blinking* or *ON* when the programmer and the PLC are communicating. It is *OFF* when they are not communicating. Note that this port is *not* used in communications between the Windows programmer and the PLC.

The bottom LED (Expansion Port Enabled) provides the status of the expansion bus. This LED is either *blinking* or *ON* when the BTM is communicating with the Bus Receiver Modules connected to it through the parallel I/O bus link. It is *OFF* when they are not communicating.

Removing a Module

The instructions below should be followed when removing a module from its slot in a rack.

- Grasp the board firmly at the top and bottom of the board cover with your thumbs on the front of the cover and your fingers on the plastic clips on the back of the cover.
- Squeeze the rack clips on the back of the cover with your fingers to disengage the clip from the rack rail and pull the board firmly to remove it from the backplane connector.
- Slide the board along the card guide and remove it from the rack.

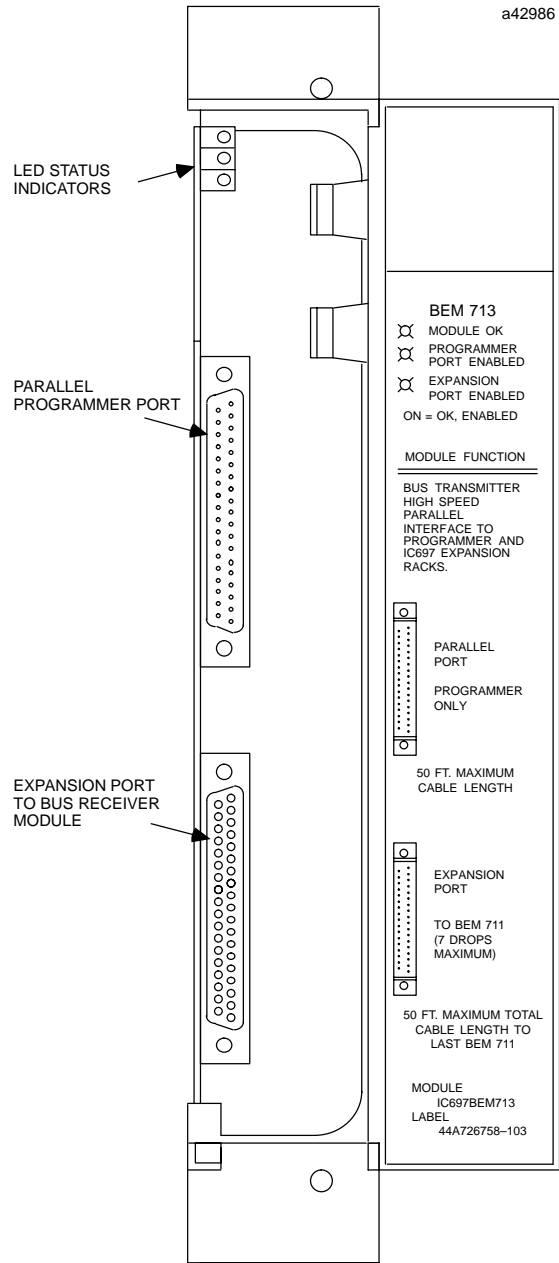

Figure 3. Bus Transmitter Module - User Details

Table 1. References

Reference	Title
1	ProgrammingSoftware User's Manual
2	ProgrammerControllerReferenceManual
3	ProgrammableControllerInstallationManual

GFK-0161H
August 1997

Bus Transmitter Module

Table 2. Specifications for IC697BEM713 †

Current Required from 5V Bus	1.4Amp
ProgrammerInterfaceSpecification	
EffectiveDataRate	50Kbytes/sec
Time to store 16 Kbyte program	20 - 30 seconds
Maximumcablelength	50 feet (15 meters)
ExpansionInterfaceSpecification	
Maximumcablelength	50 ft maximum per system
EffectiveDataRate	50kbytes/sec
ElectricalIsolation	non-isolateddifferentialcommunications.
VME	System designed to support the VME standard C.1

† Refer to GFK-0867B, or later for product standards and general specifications. For installations requiring compliance to more stringent requirements (for example, FCC or European Union Directives), refer to *Installation Requirements for Conformance to Standards*.

Table 3. Ordering Information

Description	Catalog Number
Bus TransmitterModule	IC697BEM713
ProgrammerCable, parallel	IC647CBL703 (10 ft. (3m) cable)
I/OCable	IC600WD005A (5 ft. (1.5m) cable)
	IC600WD010A (10 ft. (3m) cable)
	IC600WD025A (25 ft. (7.5m) cable)
	IC600WD050A (50 ft. (15m) cable)

Note: For Conformal Coat option, or Low Temperature Testing option please consult the factory for price and availability.

Bus Expansion Modules

IC697BEM711

GFK-0162F
August 1997

Bus Receiver Module

Features

- High Speed Parallel Bus Expansion Interface
- Supports up to seven Expansion racks
- Supports Hold Last State
- System Fault Isolation
- Three LED indicators provide module, termination, and bus expansion port status
- No DIP switches to set, easy software configuration into PLC system

Functions

This Bus Receiver Module (BRM) permits expansion from the main rack to a maximum of seven additional IC697 PLC racks with up to 50 feet (15 meters) total of interconnecting cable.

The module occupies a single slot and has two connectors, one for attachment to the upstream or CPU rack and the other for a daisy chained arrangement to additional expansion racks. The Bus Receiver Module must always be installed in slot 1.

Three green LEDs provide status indication of module status, rack activity status and presence of the I/O Bus Terminator Plug (IC697ACC702) which is required in the last rack.

The Bus Receiver Module supports hold last state operation of the output modules in the event of loss of communications with the CPU. It also permits isolation and repair of a faulty module within a rack.

The BRM must be configured into the IC697 PLC system using the MS-DOS® or Windows® programming software configuration function.

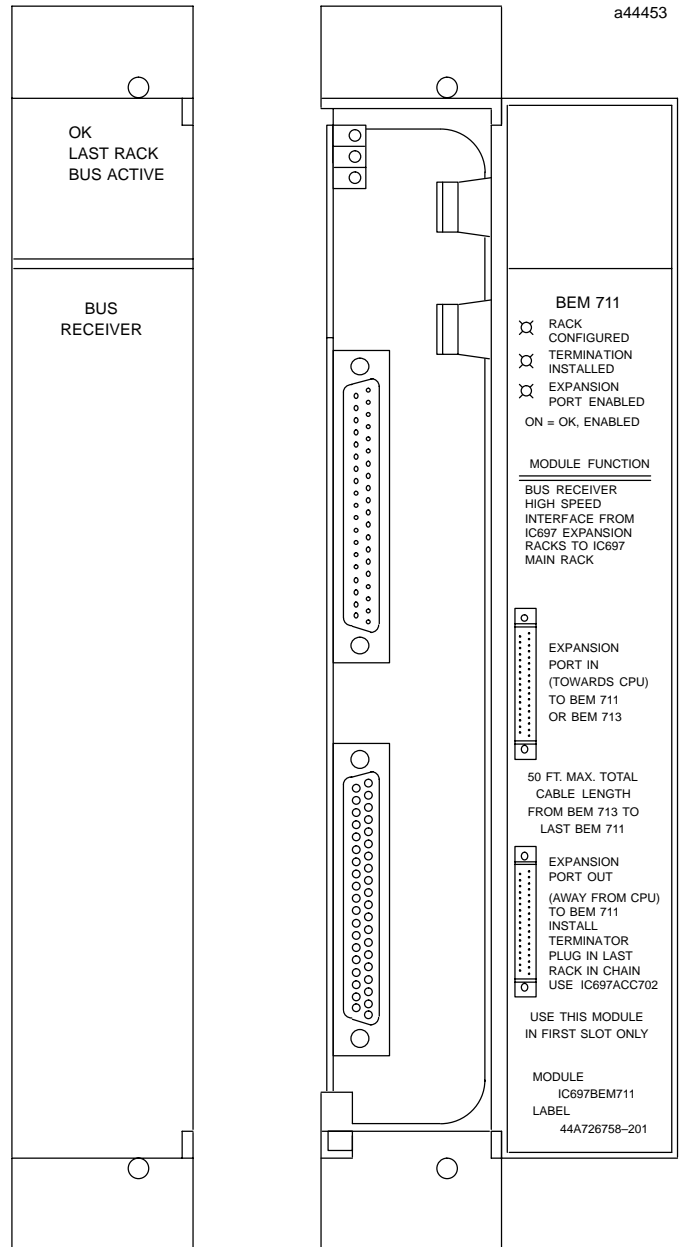

© MS-DOS and Windows are registered trademarks of Microsoft Corporation.

GFK-0162F
August 1997

Bus Receiver Module

Installation

- Installation should not be attempted without referring to the applicable *Programmer Controller Installation Manual* (see reference 3).
- Make sure rack power is off.
- Insert label inside module access door (see figure 2).
- Install in slot 1 of the rack.
- Select expansion rack ID on rack with BERG jumpers (see figure 1).
- Turn on power.

Rack Number Jumpers

When the Bus Receiver Module is installed the remote rack ID must also be set up. This is done with the BERG jumpers located behind the power supply as shown in figure 1. For more details, see Chapter 3 of the *Programmable Controller Installation Manual*.

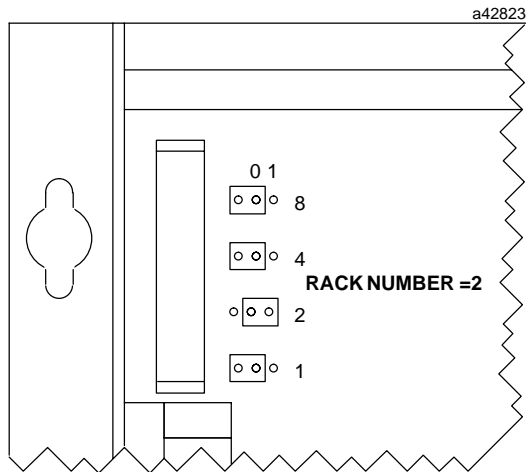

Figure 1. Rack Number Jumpers (Rack 2 Selected)

Terminator plug

The terminator plug which is supplied with each BRM is only required in the last BRM in the chain as shown in figure 2. It may be discarded or saved as a spare if this BRM is not at the end of the chain.

If this BRM is at the end of the chain, the terminator plug is installed in the lower expansion port, which is labeled EXPANSION PORT OUT. The plug should be secured with its attached screws.

Module Mechanical Keying

This module includes a mechanical key that prevents inadvertent substitution of one module type for another in a given slot. The key fits a uniquely shaped area on the board below the connector. The key is included with each module.

When the module is first installed, the key latches onto the backplane center rail. When the module is extracted, the key remains in the center rail, configuring the slot to accept only identical module types.

Expansion Rack Attachment

Using cable IC600WDxxxA (where xxx is length in feet as shown in figure 2) a Bus Transmitter Module (BTM) in the CPU rack connects to a BRM in an expansion rack. Additional expansion racks are added by daisy-chaining cabling between BRMs.

Removing a Module

The instructions below should be followed when removing a module from its slot in a rack.

- Grasp the board firmly at the top and bottom of the board cover with your thumbs on the front of the cover and your fingers on the plastic clips on the back of the cover.
- Squeeze the rack clips on the back of the cover with your fingers to disengage the clip from the rack rail and pull the board firmly to remove it from the backplane connector.
- Slide the board along the card guide and remove it from the rack.

Table 1. References

Reference	Title
1	Programming Software User's Manual
2	Programmable Controller Reference Manual
3	Programmable Controller Installation Manual

Table 2. Specifications for IC697BEM711 †

Current required from 5V Bus	0.8 amps
ExpansionInterfaceSpecification	
Maximumcablelength	50 feet (15meters)
EffectiveDataRate	50Kbytes/sec
ElectricalIsolation	Non-isolateddifferentialcommunication.
VME	System designed to support the VME standard C.1

† Refer to GFK-0867B, or later for product standards and general specifications. For installations requiring compliance to more stringent requirements (for example, FCC or European Union Directives), refer to *Installation Requirements for Conformance to Standards*.

Table 3. Ordering Information

Description	Catalog Number
Bus Receiver Module	IC697BEM711
Terminator Plug	IC697ACC702
I/O Cable	IC600WD005A, 5 ft. (1.5m)
	IC600WD010A, 10 ft. (3m)
	IC600WD025A, 25 ft. (7.5m)
	IC600WD050A, 50 ft. (15m)

Note: For Conformal Coat option, or Low Temperature Testing option please consult the factory for price and availability.

Bus Expansion Modules

IC697BEM733/735

GFK-0539C
August 1997

Remote I/O Scanner

The IC697 Remote I/O Scanner (IC697BEM733/735) is an intelligent module that mounts in a remote IC697 rack, and interfaces IC697 I/O modules to an IC66* bus.

Features

- Can be located up to 7500 feet (2275 meters) from controller.
- Supports standard IC697 discrete and analog I/O modules.
- Supports PCM, ADS, and analog expander modules.
- Handles up to 128 bytes of inputs and 128 bytes of outputs per remote drop.
- Configurable with MS-DOS® programming software configuration function or with an IC66* Hand-held Monitor.
- Compatible with all types of IC66* host.
- Supports both CPU and IC66* bus redundancy.†
- Each remote drop can include up to eight racks†, with a Remote I/O Scanner located in rack 0.
- Up to 30 remote drops can be located on the same IC66* bus.

Together, a Remote I/O Scanner and the modules it serves make up a remote drop on the IC66* bus. A

remote drop can consist of up to eight racks, linked by Bus Transmitter and Bus Receiver modules. 9-slot and/or 5-slot IC697 racks can be used. The maximum distance from the first rack to the last rack in a remote drop is 50 feet (15 meters).

The Remote I/O Scanner can handle any mix of discrete and analog inputs and outputs up to a total of 1024 discrete inputs and 1024 discrete outputs, or 64 analog inputs and 64 analog outputs (regardless of the number of racks in the remote drop). A remote drop can include all presently-available IC697 discrete modules, analog modules, and analog expander modules. Bus Transmitter, Bus Receiver, PCM, and ADS modules can also be placed in a remote drop. A remote drop cannot have any I/O module interrupts, bus controllers, communications modules, or other modules that depend on COMREQ instructions for their operations.

The Remote I/O Scanner is ideally suited for use in an IC697 PLC system. However, any type of PLC or computer capable of controlling an IC66* bus can be used as the host. Suitable hosts include IC660 PLCs, IC655 PLCs, and computers equipped with a PCIM (Personal Computer Interface Module), QBIM (Q-Bus Interface Module), or a third-party GENI-based interface.

† Remote I/O Scanner IC697BEM733/735B or later required.
* IC660 or IC661 products.

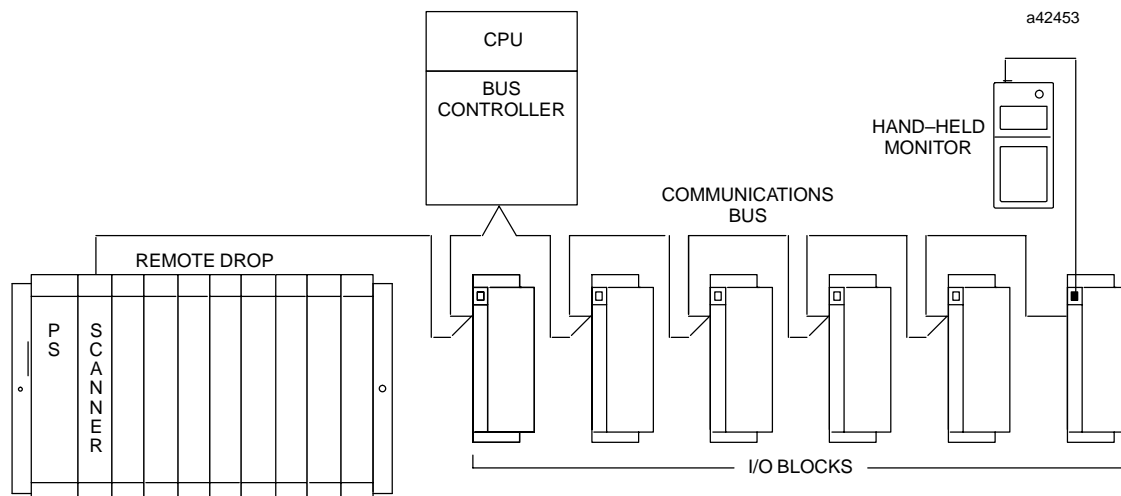

© MS-DOS is a registered trademarks of Microsoft Corporation.

GFK-0539C
August 1997

Remote I/O Scanner

Module Description

The Remote I/O Scanner consists of a single circuit board, with a hinged door which serves as a faceplate. The module does not require batteries; the faceplate battery holder is not used.

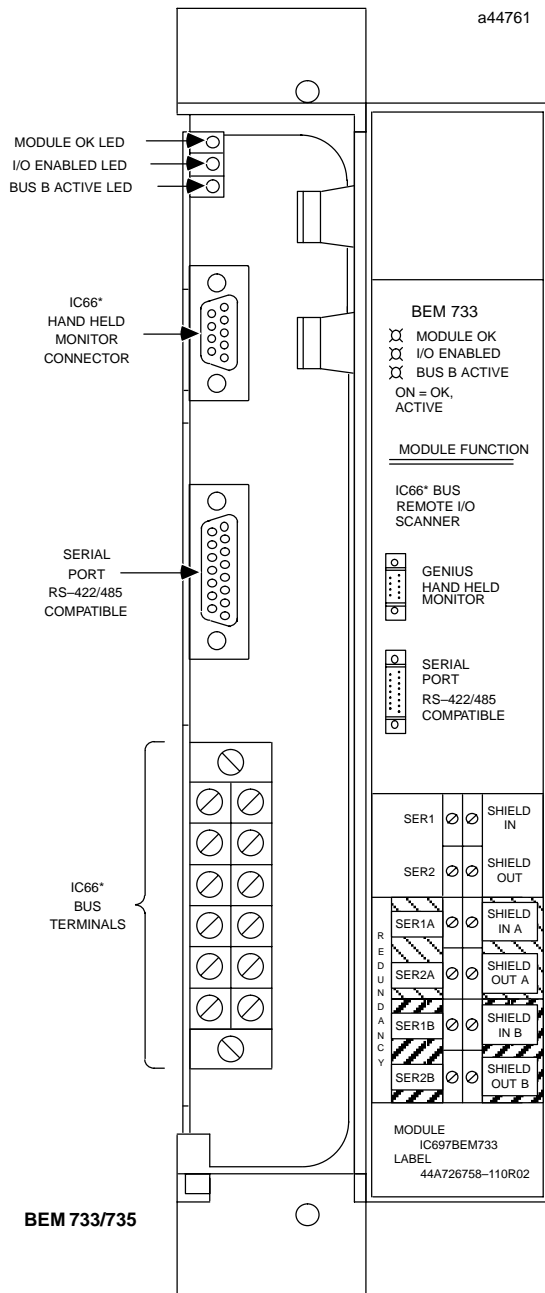

LEDs

The Remote I/O Scanner has three LEDs that show through the transparent portion at the top of the door.

Module OK lights when the module has passed its powerup diagnostic tests. If this LED flashes, it indicates a problem. If this LED is off, there is a fatal error that will cause the Remote I/O Scanner to go to stop/faulted mode.

I/O Enabled lights when the Remote I/O Scanner is receiving output data from the CPU. If this LED flashes, either I/O data is forced or there is a Device Number conflict.

Bus B Active on a dual (redundant) bus, this LED lights when Bus B is active.

The following table summarizes the LED indications.

Module OK	I/O Enabled	Meaning
On	On	Normal Operation
Blinking	On	Fault detected
On	Blinking	I/O data forced
Alternate blinking	Alternate blinking	Fault detected, and I/O data forced
Synchronous blinking	Synchronous blinking	Device Number conflict
On	Off	Outputs not being updated from CPU
Off	Off	No power or fatal error

Connectors

- 9-pin male D Connector: the upper connector. Used for attaching an IC66* Hand-held Monitor.
- 15-pin female D Connector: the center connector is an RS-422 compatible RS-485 serial port, for direct connection of a serial programmer or for connection to a multidrop communications network.
- The IC66* bus terminal strip is attached to the connector at the bottom of the module. Because the terminal strip is removable, it is possible to service or replace the module while the system is operating without disrupting bus communications.

Remote I/O Scanner

GFK-0539C
August 1997

Compatibility

This Remote I/O Scanner is compatible with:

IC66* Hand-held Monitor:

version 4.0 (IC660HHM501G) or later.

For an IC697 PLC: CPU firmware release 2.0 or later, MS-DOS programming software release 3.0 or later, Bus Controller release 3.0 or later.

For an IC600 PLC: CPU rev. 105 or later, MS-DOS programming software release 4.02 or later, Bus Controllers (IC660CBB902 or 903) must be version 1.7 or later.

For an IC655 PLC: CPU rev. 4.0 or later, MS-DOS programming software release 2.01 or later, any version Bus Controller.

For a Host Computer: any version PCIM or QBIM.

Required Equipment

The following additional equipment may be required to use a Remote I/O Scanner:

- At least one IC697 5-slot or 9-slot remote rack with power supply.
- If the parallel version of MS-DOS programming software will be used, the remote drop must include a Bus Transmitter Module (IC697BEM713).
- If the remote drop will be part of a multidrop network, which cannot be guaranteed to be on the same electrical ground and served by the same phase on the mains, isolation must be provided separately for each CPU and Remote I/O Scanner. If isolation is required, use the RS-422 Isolated Repeater/RS-232 converter (catalog number IC655CCM590), or equivalent product.

Operation

The Remote I/O Scanner scans the I/O modules in the remote drop in the same manner as an IC697 CPU scans the I/O modules in the PLC. At powerup, scanning begins immediately unless a fatal diagnostic error occurs. All I/O in a remote drop, except those that are forced, default to Off at powerup. I/O that are forced at powerup start in the forced state or value.

During operation, the Remote I/O Scanner first scans the input modules in rack and slot order, storing the input data in its own %I and %AI memories. Then, it scans the output modules in rack and slot order, send-

ing them the most recent output data from its own %Q and %AQ memories.

IC66* Communications with the Host

After the Remote I/O Scanner completes a successful login with the host, it begins data transfer on the IC66* bus. When the Remote I/O Scanner receives the IC66* bus communications token, it transmits the most recent input data from the configured portion of its %I and %AI memories. When the host's bus controller has the communications token, it sends the Remote I/O Scanner new output data from the host. The Remote I/O Scanner places the output data into the configured portion of its %Q and %AQ memories.

Remote Drop Installation

The *Remote I/O Scanner User's Manual* gives installation procedures for the racks, power supplies, and modules in a remote drop. Be sure to follow the grounding procedures carefully.

Module Locations

A remote drop can consist of up to eight IC697 racks, numbered 0 to 7. Rack numbers are configured by setting the jumpers located on the rack backplane. See the *User's Manual* for instructions. Before installing modules in a remote drop, determine where to place them.

- The Remote I/O Scanner must be located in rack 0, slot 1 (remote drop).
- A Bus Transmitter can be located in any slot of rack 0; however, there must be no empty slots between the Bus Transmitter and the Remote I/O Scanner. Slot 2 is recommended.
- In a multiple-rack remote drop, a Bus Receiver must be located in slot 1 of each expansion rack.
- A high-level analog input module and its associated expander modules must be installed in the same rack of a remote drop. *The high-level analog input module must be in the lowest slot position of the group, with the expander modules to its right.*
- Empty slots are permitted between modules, with two exceptions:
 - A. There can be no empty slots to the left of a Bus Transmitter, analog, PCM, or ADS module.
 - B. If, in the future, modules will be placed in the empty slots and a Hand-held Monitor will be

GFK-0539C
August 1997

Remote I/O Scanner

used to reconfigure the remote drop, locate empty slots to the right in the rack. Otherwise, reconfiguration will change the I/O references assigned to the boards already there.

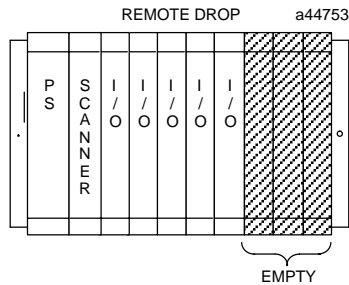

Remote I/O Scanner Installation

- Be sure the rack is powered-down.
- Grasp the module firmly and insert it into the card guide.
- Align the module's printed circuit board with the connector on the rack backplane. Slide it towards the connector until it begins to seat.
- Place one thumb on the left of the top plastic flange and the other thumb on the left of the bottom plastic flange. Push the board into the connector until the top and bottom latches click onto the rack rails.
- Be sure the module has seated properly.
- If the rack is in a high-vibration area, use screws to secure the module in the rack.

Remote I/O Scanner Removal

- Be sure the rack is powered-down.
- Grasp the module firmly at the top and bottom of the board cover with your thumbs on the front of the cover and your fingers on the plastic clips on the back of the cover.
- Squeeze the rack clips on the back of the cover with your fingers to disengage the clip from the rack rail and pull the board firmly to remove it from the backplane connector.
- Slide the printed circuit board along the card guide and remove it from the rack.

IC66* Bus Connections

For single (non-redundant) bus installations, the IC66* bus cable is connected to the upper four terminals of the Remote I/O Scanner (1 - 4 in the diagram). The lower eight terminals are not connected.

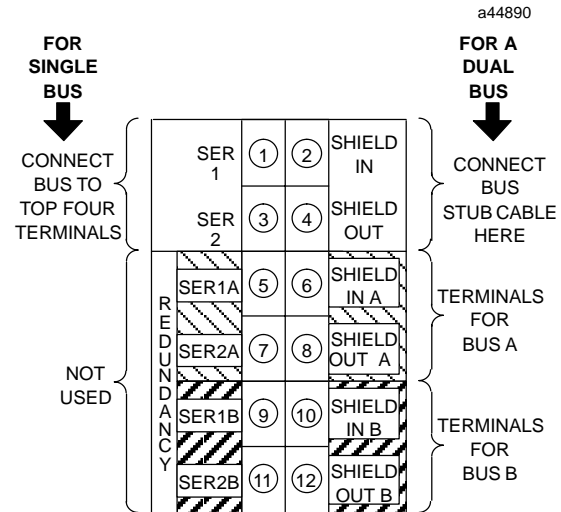

For dual (redundant) bus installations, the serial bus cable from the Bus Controller on bus A connects to the center four terminals on the terminal strip (5 - 8 in the diagram). The cable from the Bus Controller on Bus B connects to the lower four terminals (9 - 12). The Remote I/O Scanner contains an integral bus switching relay; there is no need to attach an external Bus Switching Module for dual bus configurations. If there is a bus stub from the Remote I/O Scanner to additional devices which are controlled by its bus switching action, it connects to the top four terminals (1 - 4); otherwise the top four terminals are unused.

The maximum exposed length of bare wires should be two inches. For added protection, each shield drain wire should be insulated with spaghetti tubing to prevent the Shield In and Shield Out wires from touching each other or the signal wires.

On a bus, connect Serial 1 to the Serial 1 terminals of the previous device and the next device. Connect Serial 2 to the Serial 2 terminals of the previous device and the next device. Connect the Remote I/O Scanner's Shield In terminal to Shield Out of the preceding device. Connect Shield Out to Shield In of the next device. If the Remote I/O Scanner is the first de-

Remote I/O Scanner

GFK-0539C
August 1997

vice on a bus, Shield In can be left unconnected. If it is the last device on a bus, Shield Out can be left unconnected. Note that the IC66* bus connections for a Remote I/O Scanner are not the same as the connections for an IC697 bus controller, even though the terminals are physically identical.

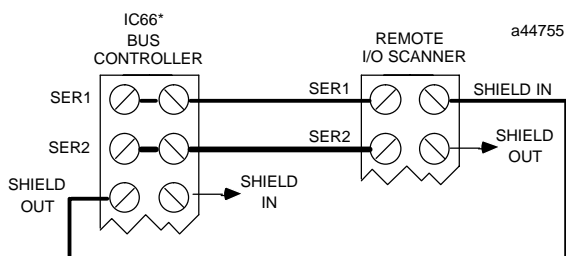

IC66* Bus Termination

If the Remote I/O Scanner is at either end of a bus (electrically), connect the appropriate terminating resistor across the Serial 1 and Serial 2 terminals. Impedance for the IC66* bus will be 75, 100, 120, or 150 ohms. Chapter 2 of the *I/O System User's Manual* (for IC660*) lists the correct impedance to use for each approved type of bus cable.

In a redundant bus application, if either cable of the dual bus ends at the Remote I/O Scanner, it must have its own terminating resistor. The upper four connectors are *never* terminated in a dual bus configuration.

Note

If the Remote I/O Scanner will be powered up when not connected to a properly-terminated bus, connect a 75-ohm resistor across its Serial 1 and Serial 2 terminals to assure proper powerup.

Serial Port Connections

The Remote I/O Scanner's serial port can be used for connection to a multidrop communications network or for direct connection of a programmer running the serial version of IC641 Programming Software.

Serial Port Termination

If the Remote I/O Scanner will be **at the end** of a communications network, or if a programmer will be con-

nected directly to it, the serial port must be terminated by connecting a 220 ohm resistor across pins 10 and 11 and another 220 ohm resistor across pins 8 and 15. These connections must be made inside the connector's D-shell. At the other end of the cable, terminate the SD and RTD pins in the same way.

Direct Programmer Connections

If the programmer is equipped with the parallel version of MS-DOS programming software and a Workstation Interface board, connection is made to a Bus Transmitter module in rack 0.

If the programmer is equipped with the serial version of MS-DOS programming software and a Workstation Interface board, connection is made to the serial port on the Remote I/O Scanner module.

If the programmer does not have a Workstation Interface board, connection must be made via an intermediate RS422/RS485 to RS232 converter.

If the serial port is needed for connection to a multi-drop communications network, an intermediate connector can be used. See the *Remote I/O Scanner User's Manual* for details.

Programmer Grounding

For proper operation, the programmer must have a ground connection in common with remote drop rack 0. Normally, the common ground connection is provided by connecting the programmer's power cord to the same power source (with the same ground reference point) as the rack. If a common ground cannot be established, use the RS-422 Isolated Repeater/RS-232 Converter IC655CCM590, or an equivalent product to protect the equipment.

Configuration

A Remote I/O Scanner must be configured to:

- Assign its Device Number (serial bus address).
- Assign its baud rate.
- Specify starting references and lengths for discrete inputs and outputs, and for analog inputs and outputs.
- Specify the Remote Drop ID.

GFK-0539C
August 1997

Remote I/O Scanner

Configuration can be done with:

- MS-DOS programming software release 3.0 or later. This software provides full configuration of I/O modules and allows selection of module options.
- **An IC66* Hand-held Monitor**, version 4.0 or later. The HHM automatically assigns I/O references to the modules in the remote drop. *The I/O modules in the remote drop operate in default mode if a Hand-held Monitor is used to enter or change configuration.* If the remote drop includes any analog expanders, a Hand-held Monitor cannot be used for configuration.

IC697 PLC Configuration

If the system host is an IC697 PLC, each Remote I/O Scanner must be added to the PLC configuration. With MS-DOS programming software release 3.0 or later, a separate program folder should be created for each remote drop. The folders should be organized so that the remote drop folders are located in the central PLC folder. The *Remote I/O Scanner User's Manual* gives complete configuration instructions.

Specifications †

Module Type	IC697RemoteI/OScannedIC697BEM733/735
LEDs	Module OK, I/O Enabled, Bus B Active
Size	Occupies single slot in IC697 remote rack
Ports	One 15-pin RS-422/485 compatible serial port, one 9-pin IC66* Hand-held Monitor port.
Current Required from +5V Bus	0.8 amps
Bus Type	Daisy-chained bus cable; single twisted pair plus shield or Twinax. Fiber optics cable and modems can also be used.
Bus Termination	75, 100, 120, or 150 ohm resistor at both ends of electrical bus cable.
Baud Rate	Configurable. 153.6 Kbaud standard, 153.6 Kbaud extended, 76.8 Kbaud, or 38.4 Kbaud.
Maximum Bus Length	7500 feet (2275 meters) at 38.4 Kbaud, 4500 feet (1365 meters) at 76.8 Kbaud, 3500 feet (1060 meters) at 153.6 Kbaud extended, 2000 feet (605 meters) at 153.6 Kbaud, standard. Maximum length at each baud rate also depends on cable type. The <i>IC66* I/O System User's Manual</i> provides a complete list of cable types, showing corresponding bus lengths and baud rates.
Maximum Number of Devices per Bus	32 devices at 153.6 Kbaud standard, 153.6 Kbaud extended, or 76.8 Kbaud. 16 devices at 38.4 Kbaud. Includes bus controller and Hand-held Monitor.
Maximum Number of Remote Drops per Bus	Depends on baud rate as follows:
153.6Kbaud extended	Up to 20 fully-loaded drops, or up to 30 drops if not fully-loaded.
153.6Kbaud standard	Up to 20 fully-loaded drops, or up to 30 drops if not fully-loaded.
76.8Kbaud	Up to 10 fully-loaded drops, or up to 30 drops if not fully-loaded.

† Refer to GFK-0867B, or later for product standards and general specifications. For installations requiring compliance to more stringent requirements (for example, FCC or European Union Directives), refer to *Installation Requirements for Conformance to Standards*.

Note: For Conformal Coat option, or Low Temperature Testing option please consult the factory for price and availability.

For More Information,

- Please refer to these related publications:
- Remote I/O Scanner Module User's Manual.*
 - Programmable Controller Installation Manual.*
 - Programming Software User's Manual.*
 - Programmable Controller Reference Manual.*

GFK-0645C
August 1997

I/O Link Interface Module

Module Features

- IC697 PLC interface to CNC-compatible serial I/O link.
- I/O Link master or slave.
- Occupies single slot in PLC rack.
- Three status LEDs
- I/O Link reset pushbutton.
- 1.5 MHz serial port transmission rate.

Overview

The Fanuc I/O Link is a serial interface that provides high-speed exchange of I/O data between a master device and up to 16 slaves. The maximum distance between individual devices on an I/O Link is 10 meters (33 feet). If greater distances are required between modules, optional fiber optics cable and Optical Adapters can be used to increase the maximum distance between individual devices to 100 meters (330 feet).

Up to four I/O Link Interface Modules can be installed in an IC697 PLC. Each I/O Link Interface Module can be used in either master or slave mode. Usually, when there are multiple I/O Link Interface Modules in the same PLC, they are on separate I/O Links. However, it is possible to have more than one I/O Link Interface Module in the IC697 PLC connected to the same link, if that suits the needs of the application.

When used as a master, an I/O Link Interface Module can exchange up to 1024 discrete inputs and 1024 discrete outputs with slave devices. Potential slaves include the IC693 PLC, Series 0 CNC, and Power Mate CNC.

When used as a slave, the IC697 I/O Link Interface Module can exchange up to 64 discrete inputs and 64 discrete outputs with the master. The master may be another IC697 PLC, a Series 15, Series 16, or Series 18 CNC, a Series 0 Model C CNC, or an F-D Mate CNC. The IC697 PLC and Series 0 CNC can be used as either master or slave.

© MS-DOS is a registered trademark of Microsoft Corporation.

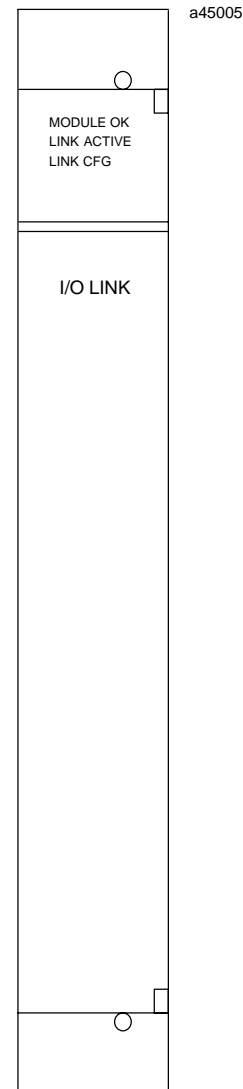

The I/O Link Module is configured using the MS-DOS® programming software. Application software, supplied on diskettes with the I/O Link Module, can be used to set up and control the I/O Link. This application software can also be used to assign the location of the input and output data to and from the I/O Link, and to provide diagnostics capabilities for the I/O Link. The MS-DOS programmer is used to integrate this application software with the rest of an application program.

GFK-0645C
August 1997

I/O Link Interface Module

Module Description

The I/O Link Interface Module occupies one slot in the IC697 PLC rack. It can be installed in any rack, in any slot except slot 1, which is reserved for the CPU module.

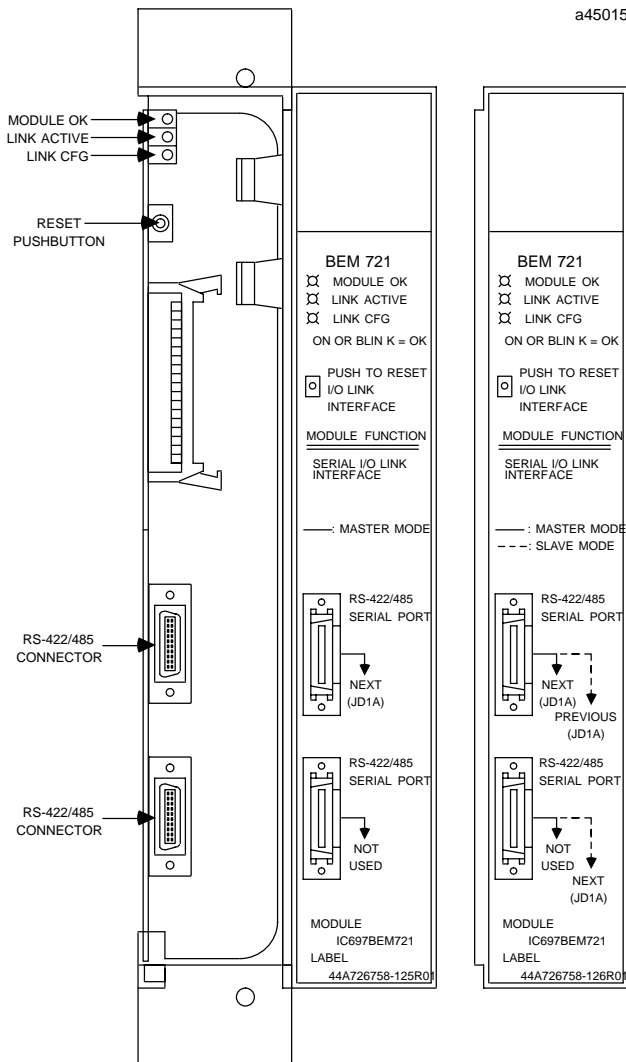

LEDs

The module has three LEDs that show its operating, configuration, and communications status.

- Module OK:** indicates the module's operating status.
- Link Active:** indicates the module's communications status.
- Link Cfg:** indicates whether I/O Link configuration has occurred.

Reset Pushbutton

The Reset pushbutton provides a convenient means of reset if a failure occurs. If the module is being used as a master, pushing the Reset button resets both the module and operation of the link. The application program must be used to re-initialize the link. If the module is being used as a slave, pushing the Reset button resets the module, if a fault has caused the module to stop operating while the rest of the link continues to function.

Serial Ports

The front of the I/O Link Interface Module has two 20-pin, D connector, RS-422/485 serial ports. These ports are used for connection to the Fanuc I/O Link.

Application Software

The IC697 I/O Link Interface Module is provided with an application software diskette. Program logic on the diskette can be used to integrate up to four I/O Link Interface Modules into the PLC's application program. It will transfer I/O data between the module and the PLC, perform diagnostics functions, and transfer application program commands to the module. Additional application program logic can be created to perform the following functions:

1. To specify the number of I/O Link Interface Modules present in the PLC.
2. To specify, for each I/O Link Interface Module:
 - A. A rack and slot location.
 - B. Master or slave operation.
3. And, for each I/O Link Interface Module that will be a master:
 - A. To assign a data length and I/O addresses for each slave on its link.
 - B. To control operation of the link and monitor module and link status.

The *I/O Link Interface Module User's Manual* (GFK-0644), chapter 4, explains how to add logic for I/O Link Interface Modules to an application program.

I/O Link Interface Module

GFK-0645C
August 1997

Module Installation

The I/O Link Interface Module can be installed in any rack, in any slot except slot 0, which is reserved for the CPU module. The only placement restriction is the module not be located to the left of any board that generates interrupts (such as a PCM, IC66* Bus Controller, Analog, Factory LAN, or Ethernet module).

Caution

Rack power MUST be OFF when installing or removing the I/O Link Module.

1. Grasp the module firmly with your hand and insert it into the card guide.
2. Align the module's printed circuit board with the connector on the rack backplane and slide it towards the connector until it has started to seat.
3. Place one thumb on the left side of the top plastic flange and the other thumb on the left side of the bottom plastic flange. Push the board into the connector until the top and bottom latches click onto the rack rails.
4. Visually inspect the board to be sure it has seated properly.

Caution

Make sure no exposed wiring touches any conductive material. Such contact could damage the module, and other units to which it is connected.

5. A CPU module must be present in rack 0 slot 1 before applying power to the I/O Link Interface Module. Turn on power, and observe the LEDs.

LED Status	LED Status	Indication
Module OK	On	The I/O Link Module has passed its powerup diagnostics and the hardware is operating properly.
	OFF	The module has failed a diagnostic test, or a run-time failure has been detected.
	Blinking	The module is running powerup diagnostics.
Link Active	On	The module is ready to communicate with the I/O Link.
	OFF	A failure has occurred with the I/O Link, and communications are not possible.
	Blinking	The module is transferring data on the I/O Link.
Link Cfg	ON	I/O Link configuration has occurred, and the module is ready to communicate.
	OFF	The module has not been configured for link operation.

Module Removal

1. Remove power from the rack.
2. Grasp the module firmly at the top and bottom of the board cover, with your thumbs on the front of the cover, and your fingers on the plastic clips on the back of the cover.
3. Squeeze the rack clips on the back of the cover to disengage the clips from the rack rail.
4. Pull the module firmly to remove it from the backplane connector.
5. Slide the board along the card guide and remove it from the rack. Avoid contact with neighboring boards and wiring.

GFK-0645C
August 1997

I/O Link Interface Module

Cable Types for the I/O Link

The following cables and connectors can be used to complete the I/O Link between devices.

Item	Catalog Number	Vendor	Description
Cable	A03B-0807-K801	†	5 meter length with connectors on both ends. Connects between master and slave device, or between two slave devices.
Cable	A03B-0807-K802	†	10 meter length with connectors on both ends. Connects between master and slave device, or between two slave devices.
Cable	AMW2076	OKI Electric Cable	10-pair shielded cable without connectors, for making custom-length cable. Connects between master and slave device, or between two slave devices.
Connector	A02B-0120-K301	†	20-pin connector with solder lug. Consists of the two following parts.
Connector	PCR-E20FS	Honda	20-pin female connector with solder lug.
	PRC-V20L	Honda	Connector cover.
Cable	A03B-0807-K803	†	1 meter length with connectors on both ends. Connects between master or slave and Optical Adapter. This cable can only be used with an Optical Adapter; do not use it for master/slave or slave/slave connections.
Optical Adapter	A138-154-B001	†	Required for optical fiber cable.
Cable	A66L-6001-009	†	Optical fiber cable for use with Optical Adapter
	" #L10R03		10m
	" #L15R03		15m
	" #L20R03		20m
	" #L30R03		30m
	" #L40R03		40m
	" #L50R03		50m
	" #L60R03		60m
	" #L80R03		80m
	" #L90R03		90m
	" #L100R03		100m

† See your local PLC distributor or local sales office for purchasing information.

I/O Link Interface Module

GFK-0645C
August 1997

I/O Link Connection

The devices on an I/O Link must be installed in the order expected by the master. If the IC697 PLC is the master, be sure to connect the devices on a link in the order that agrees with the information provided to the application Program Block.

Using the appropriate cable, connect the devices on the link. Notice that the cables are marked JD1A on one end and JD1B on the other.

The functions of the ports on the I/O Link Interface Module depend on whether the module is used as a master or as a slave. Refer to the illustrations below.

I/O Link Module Used as a Master

If the module will be used as a master, connect the cable from the first slave to the upper port. The lower port is not used in master mode.

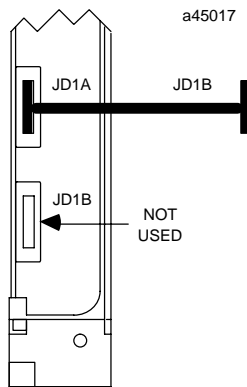

I/O Link Module Used as a Slave

If the module will be used as a slave, connect the cable from the previous device (either the master or another slave) to the upper port. If the module is followed by another slave on the link, connect the cable from that device to the lower port.

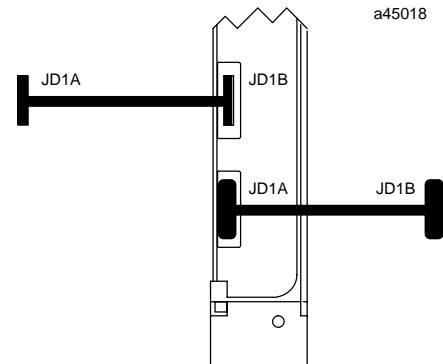

Serial Port Pin Assignments

Pin #	Signal	Pin #	Signal
1	SIN	11	0 volts
2	*SIN	12	0 volts
3	SOUT	13	0 volts
4	*SOUT	14	0 volts
5		15	0 volts
6		16	0 volts
7		17	
8		18	+5 volts
9	+5 volts	19	
10		20	+5 volts

The +5-volt output from each connector powers the fiber optic link modules for long distance applications. The +5-volt output is not used otherwise.

Caution

Do not use a cable that includes the +5 volt line (cable A03B-0807-K803) to directly connect I/O Link devices. Damage to the equipment may result.

If the link includes Optical Adapters and fiber optic cables, please refer to the *I/O Link Interface Module User's Manual* for installation instructions.

GFK-0645C
August 1997

I/O Link Interface Module

Module Specifications †

Physical dimensions:	6.3in x 9.19in (160mm x 233mm). Single slot in IC697 rack.
Module type:	IC697 PLC module, providing I/O Link communications with up to 16 slave devices in master mode.
Current requirement from +5-volt bus	1.0 Amp without Optical Adapter 0.2 Amps per Optical Adapter
LEDs: Pushbutton: Configuration: In master mode In slave mode	Module OK, I/O Link Active, I/O Link Configured Reset I/O Link Controls up to 16 slaves Choice of 32 or 64 inputs/outputs per slave. Controlled by one master Choice of 32 or 64 inputs/outputs
I/O Points: In master mode In slave mode	1024 inputs, 1024 outputs maximum (64 inputs/outputs per slave maximum) 64 inputs, 64 outputs maximum
PLC capacity (examples; for further details, refer to the I/O Link Module User's Manual): 781 CPU 771 CPU 731 CPU	Up to four I/O Link Modules Up to two I/O Link Modules One I/O Link Module
RS-422/485 Serial Ports:	1.5 MHz transmission rate.

† Refer to GFK-0867B, or later for product standards and general specifications. For installations requiring compliance to more stringent requirements (for example, FCC or European Union Directives), refer to *Installation Requirements for Conformance to Standards*.

Note: For Conformal Coat option, or Low Temperature Testing option please consult the factory for price and availability.

For More Information,

Please refer to these related publications:

I/O Link Module User's Manual (GFK-0644).

Programmable Controller Installation Manual (GFK-0262).

Programming Software User's Manual (GFK-0263).

Programmable Controller Reference Manual (GFK-265).

Bus Expansion Modules

IC697BEM761

GFK-0096F
July 1995

I/O Interface Module for the IC600 PLC

Features

- Interfaces IC697 I/O modules to the I/O bus of an IC600 programmable controller
- Rack-dependent I/O references
- Supports up to eight racks per I/O system

Functions

The **I/O Interface Module** to the IC600 programmable control provides an interface between the IC600 I/O bus and IC697 I/O modules. The I/O Interface Module resides in an IC697 rack and has two 37-pin connectors identical to those used on the IC600 I/O Receiver for interconnection to the IC600 I/O bus.

IC600 PLC systems may be configured to include IC600I/O, IC697I/O, and IC660I/O. Both IC600 and IC697 I/O racks may be included on a single I/O chain.

Each IC697 I/O rack is assigned 128 (five-slot rack) or 256 (nine-slot rack) I/O references. Up to eight such racks may be used in a system, providing up to 2000 addressable points. Any point can be used for an input or an output.

A minimum of 8K registers in the IC600 PLC are required for operation of the I/O Interface Module.

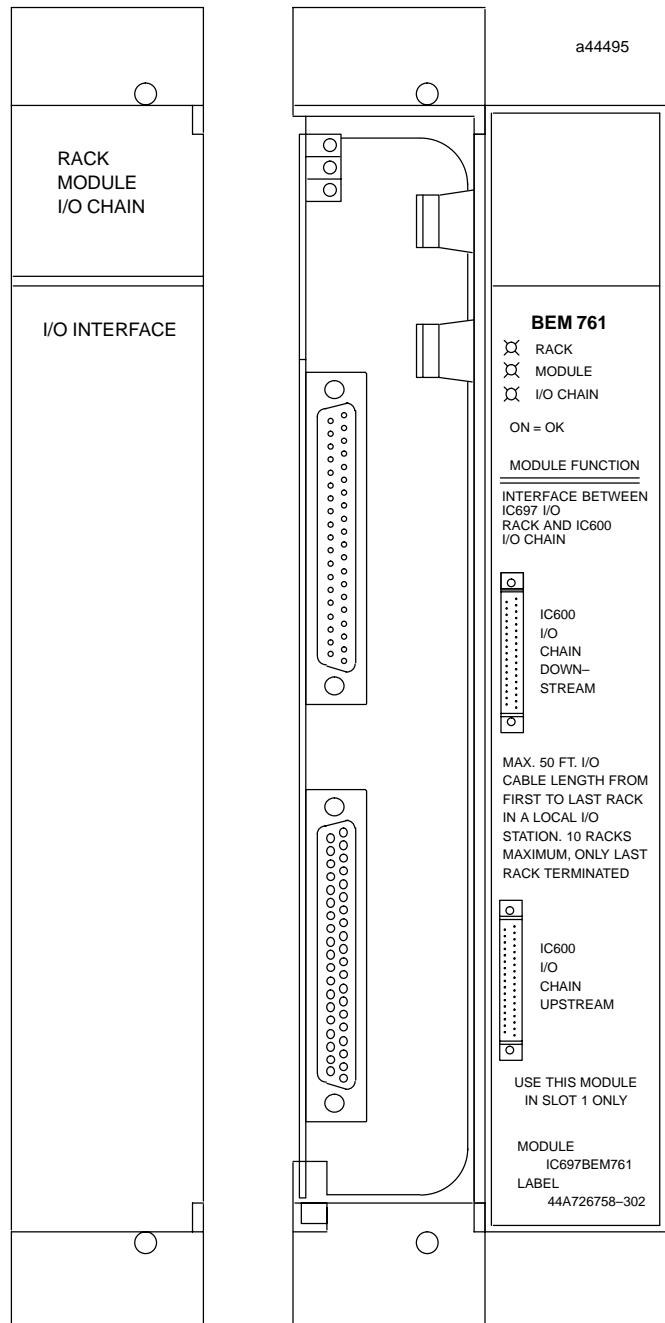

GFK-0096F
July 1995

I/O Interface Module for the IC600 PLC

Operation of the Module

The I/O Interface Module is an intelligent module that allows IC697 I/O racks to interface to the IC600 I/O chain. In operation, the I/O Interface Module reads/writes data to each I/O module in the rack. It exchanges this data with the IC600 CPU via the I/O bus.

An I/O chain may include up to eight IC697 I/O racks, as well as additional IC600 racks. Each IC697 rack has nine or five slots - one for the I/O Interface Module,

and eight or four for the I/O modules. Although IC697 I/O modules themselves may have 16 or 32 points, each of the eight available I/O slots in the IC697 rack is assigned 32 discrete points. Thus a nine-slot rack fully populated with 32 point modules will have 256 points (128 for a five-slot rack), giving a maximum system size of 2000 points (896 for a five-slot rack). Table 1 shows I/O mapping by rack and slot.

The I/O Interface Module must be inserted in slot 1 (next to the Power Supply slot) with slots 2 through 9 reserved for I/O modules.

Table 1. I/O Mapping by Rack and Slot

Addressing		Rack No.	Slot Number							
			2	3	4	5	6	7	8	9
I/O	Standard	0	1- 32	33- 64	65- 96	97-128	129-160	161-192	193-224	225- 256
		1	257-288	289-320	321-352	353-384	385-416	417-448	449-480	481- 512
		2	513-544	545-576	577-608	609-640	641-672	673-704	705-736	737- 768
		3	769-800	801-832	833-864	865-896	897-928	929-960	961-992	*993-1000
	Complementary	4	1- 32	33- 64	65- 96	97-128	129-160	161-192	193-224	225- 256
		5	257-288	289-320	321-352	353-384	385-416	417-448	449-480	481- 512
		6	513-544	545-576	577-608	609-640	641-672	673-704	705-736	737- 768
7		769-800	801-832	833-864	865-896	897-928	929-960	961-992	*993-1000	
AI AO	Standard	8	1- 32	33- 64	65- 96	97-128	129-160	161-192	193-224	225- 256
		9	257-288	289-320	321-352	353-384	385-416	417-448	449-480	481- 512
		10	513-544	545-576	577-608	609-640	641-672	673-704	705-736	737- 768
		11	769-800	801-832	833-864	865-896	897-928	929-960	961-992	*993-1000
	Complementary	12	1- 32	33- 64	65- 96	97-128	129-160	161-192	193-224	225- 256
		13	257-288	289-320	321-352	353-384	385-416	417-448	449-480	481- 512
		14	513-544	545-576	577-608	609-640	641-672	673-704	705-736	737- 768
15		769-800	801-832	833-864	865-896	897-928	929-960	961-992	*993-1000	

* Do not use these I/O points if this rack contains an Advanced I/O Receiver. Refer to GFK-0152, the IC600 PLC to IC697 I/O User's Manual for further details.

Rack Number

The 2000 I/O points are mapped into the Main I/O table (I/O 0001-I/O 1000) and the Auxiliary I/O table (AI/AO 0001-AI/AO 1000). The rack number is set by configuring a group of jumpers located on the rack backplane directly behind the power supply.

This number determines the location in the Main I/O

table or Auxiliary I/O table to which I/O points for that rack will be mapped. Racks 0, 1, 2, and 3 are mapped into the Main I/O Table and racks 8, 9, 10, and 11 are mapped into the Auxiliary I/O table. Racks 4 through 7 and 12 through 15 are used only for complementary I/O addressing, which is explained later.

I/O Interface Module for the IC600 PLC

GFK-0096F
July 1995

Setting the Rack Number

The rack number is set by jumpers on the backplane behind the power supply. Jumper positions are set so that the sum of those digits with the jumper in the "1" position is the desired rack number.

For example, rack number 2 would have the 2 jumper in the 1 position and the 1, 4, and 8 jumpers in the 2 position.

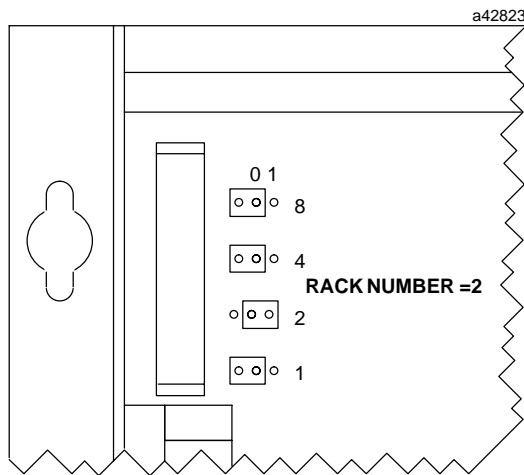

Figure 1. Example of Setting Rack Number

Reserved I/O References

Each IC697 rack uses a reserved I/O reference address (shown in table 2) as part of the communications scheme with the IC600 CPU. This reserved I/O reference address may *not* be used to address IC600 I/O or IC660 I/O if the corresponding IC697 rack is in use.

For example, if rack number 2 is used, addresses 529-536 may not be used for IC600 I/O or IC660 I/O references. It may, however, be used by other IC697 I/O racks.

References 1001 to 1024 are reserved by the IC600 PLC for interrupts and system operation. Therefore, slot 9 in racks 3, 7, 11, and 15 should be unoccupied (see table 1).

Registers 8060 through 8074 and registers shown in Table 2 are reserved for control and status information. Use of these registers is described in the *IC600 PLC to IC697 I/O User's Manual (GFK-0152)*.

Table 2. I/O Rack Address Assignments and Reserved Addresses

Rack No.	IC600 I/O Range	Reserved I/O Reference Addresses	Reserved Registers
0	I/O 1-256	513-520	R8075-R8077
1	I/O 257-512	521-528	R8078-R8080
2	I/O 513-768	529-536	R8081-R8083
3	I/O 769-1000	537-544	R8084-R8086
4	I/O 1-256	545-552	R8087-R8089
5	I/O 257-512	553-560	R8090-R8092
6	I/O 513-768	561-568	R8093-R8095
7	I/O 769-1000	569-576	R8096-R8098
8	AI/AO 1-256	577-584	R8099-R8101
9	AI/AO 257-512	585-592	R8102-R8104
10	AI/AO 513-768	593-600	R8105-R8107
11	AI/AO 769-1000	601-608	R8108-R8110
12	AI/AO 1-256	609-616	R8111-R8113
13	AI/AO 257-512	617-624	R8114-R8116
14	AI/AO 513-768	625-632	R8117-R8119
15	AI/AO 769-1000	633-640	R8120-R8122

GFK-0096F
July 1995

I/O Interface Module for the IC600 PLC

I/O Cable Connections

The I/O Interface Module provides two 37-pin connectors for interfacing to the IC600 I/O bus. The lower connector accepts the upstream cable from the IC600 local I/O chain. The upper connector accepts the downstream cable which goes to additional racks.

The I/O cable is connected to the I/O Interface Module as shown below.

Note

Some IC600 I/O cables are constructed so that the cable enters the connector from the top rather than the bottom as required by the I/O Interface Module. These cables can easily be modified by removing the connector shell, reversing the position of the D-connector housing, and reassembling the shell.

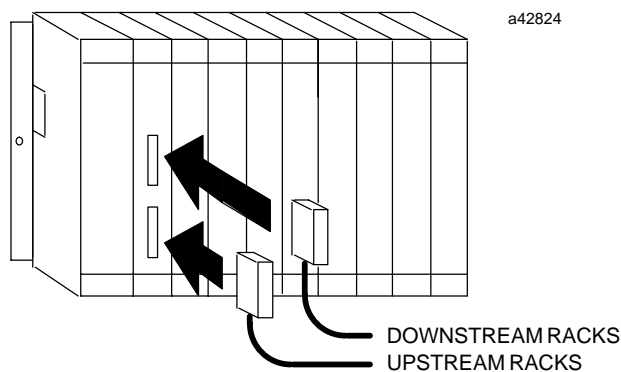

Figure 2. Cable Connections to I/O Interface Module

Termination Resistors

The I/O Interface Module includes line termination resistors which must be set correctly in each I/O Interface Module for proper operation. For I/O Interface Modules which are at the end of a chain, place the termination resistor packages in *position A* as shown below. For I/O Interface Modules at any other location in the chain, set the termination resistor packages to *position B*.

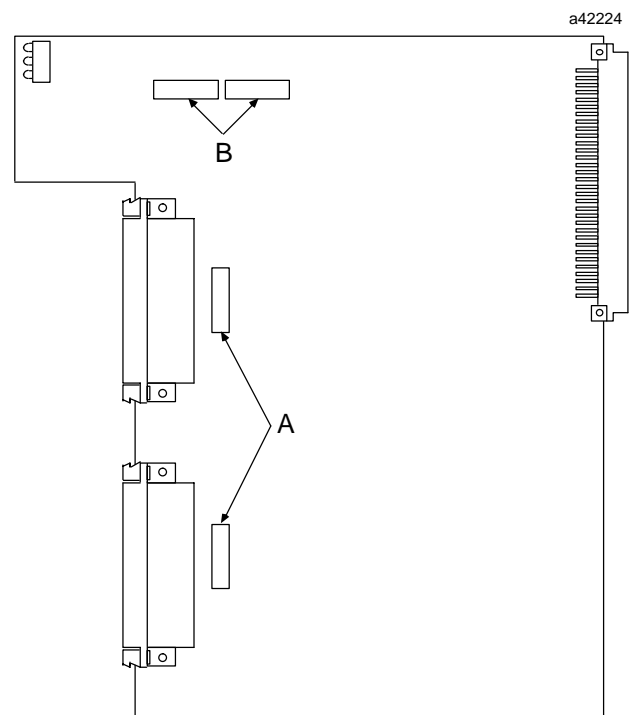

Figure 3. Location of Termination Resistors

LED Indicators

There are three LEDs on the front of the I/O Interface module:

- RACK: Indicates faults within the rack
- MODULE: Indicates faults in the I/O Interface Module
- I/O CHAIN: Indicates a downstream rack fault or I/Obusfailure

The normal condition is for all LEDs to be on.

If any LED is off or if the system is not operating normally, refer to Table 3 for troubleshooting information.

If all three LEDs are off, look for a common fault, such as lack of AC input power or a faulty power supply.

If both the RACK and MODULE LEDs are off, the fault is probably located in the I/O Interface Module.

If only the RACK LED is off, the fault is probably in another module in the same rack, not the I/O Interface Module.

Table 3. Troubleshooting Using LEDs

<i>LED Indicators</i>					
Module	Rack	I/O Chain	Failure Type	Possible Causes	Recommended Action
OFF	OFF	OFF	Common fault	No AC power Power supply failure	Check AC power source Check +5 VDC Bus LED on power supply
ON	OFF	ON	Rack fault	Output module fuse blown in the rack	Check fuse LEDs on output boards
ON	OFF	OFF		I/O module failure in the rack	Remove each I/O module in turn <i>Always Remove Power Before Removing or Inserting A Module</i>
OFF	OFF	ON	I/O Interface Module fault	Internal I/O Interface Module fault	Check I/O Interface Module seating Replace faulty module
ON	ON	OFF	Downstream I/O fault	Loss of communications to downstream racks	Check cabling to downstream racks
ON	OFF	OFF		Failure of downstream racks	Check operation of downstream racks

GFK-0096F
July 1995

I/O Interface Module for the IC600 PLC

Complementary Addressing

For applications requiring more than 2000 points, a complementary addressing technique may be used. Complementary addressing can extend the system capacity to a maximum of 2000 inputs and 2000 outputs.

The I/O references for each slot (2-9) are fixed for a given rack. Table 1 defines an address range of 32 points for each slot of 16 total racks. Note that for both the main and auxiliary I/O tables, a given I/O point is referenced twice. For example, point 1 is referenced in both rack 0 and rack 4.

If racks 0 and 4 are both used (as shown in the example) the I/O modules for a given slot must be complementary; that is, if an input module is installed in a slot then only an output module may be installed in the corresponding slot in its complementary rack.

In the following example of complementary addressing, slot 5 in rack 0 is occupied by an input module, so slot 5 in rack 4 (complementary to rack 0), must either be used for an output module or left vacant. The example also shows slot 6 in racks 0 and 4 using complementary modules (output module in rack 0 and input module in rack 4).

Additional racks (such as 1 and 5, 2 and 6) have similar complementary addressing.

Removing a Module

The instructions below should be followed when removing a module from its slot in a rack.

- Grasp the board firmly at the top and bottom of the board cover with your thumbs on the front of the cover and your fingers on the plastic clips on the back of the cover.
- Squeeze the rack clips on the back of the cover with your fingers to disengage the clip from the rack rail and pull the board firmly to remove it from the backplane connector.
- Slide the board along the card guide and remove it from the rack.

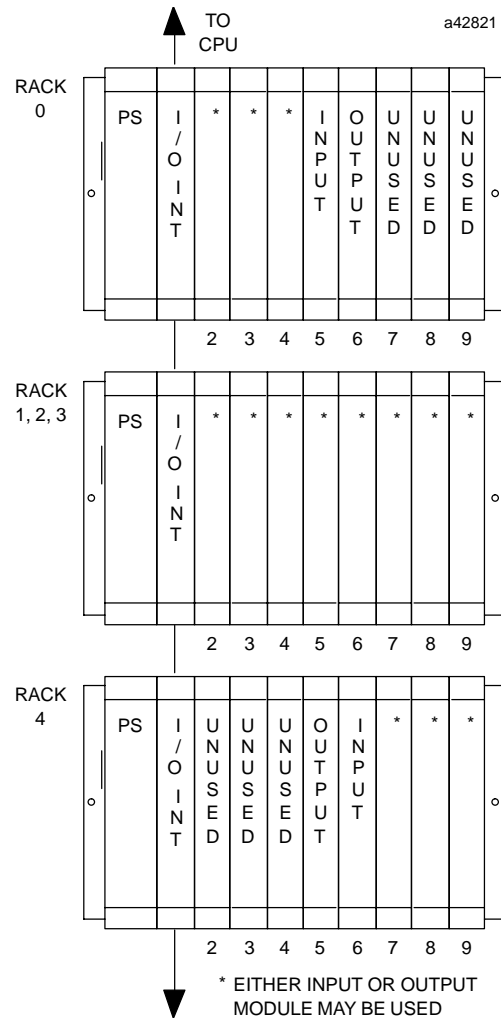

* Either input or output module may be used.

Figure 4. Example of Complementary Addressing

Note

Slot 9 in racks 3, 7, 11, and 15 not used. See Table 1 for details.

I/O Interface Module for the IC600 PLC

GFK-0096F
July 1995

Table 4. Specifications for IC697BEM761 †

Operational: ‡	
Number of Racks:	8maximum 16 with complementary addressing
I/O Points per Rack:	256maximum
I/O Points per System:	2000maximum 4000 with complementary addressing
Current Req. from 5V Bus:	1.3 amps
VME	System designed to support the VME standard C.1

† Refer to GFK-0867B, or later for product standards and general specifications.

‡ Excludes IC600I/O and IC660I/O; refer to the applicable users manual for specifications.

Table 5. Ordering Information

Description	Catalog Number
I/O Interface to IC600 PLC Module	IC697BEM761
I/O Cables: 2 feet	IC600WD002
5 feet	IC600WD005
10 feet	IC600WD010
25 feet	IC600WD025
50 feet	IC600WD050
100 feet	IC600WD100
200 feet	IC600WD200
300 feet	IC600WD300
400 feet	IC600WD400
500 feet	IC600WD500

GFK-0532K
August 1997

Ethernet Controller

- Direct PLC attachment to IEEE 802.3 CSMA/CD LAN
- Standard 15-pin AUI port connection allows choice of 10Base5, 10Base2, 10BaseT, 10BaseF, or 10Broad36 medium with user-supplied 802.3-compatible transceiver
- For IC697 programmable controllers
- Occupies a single slot in PLC rack
- Software (separately licensed) is easily loaded or upgraded via RAM load
- Software is retained through power outages for a minimum of six months
- Alternative software packages provide:
 - TCP/IP communications
 - MMS/OSI communications
 - Full MS-DOS® or Windows® programming and configuration services
 - Comprehensive station management and diagnostic tools

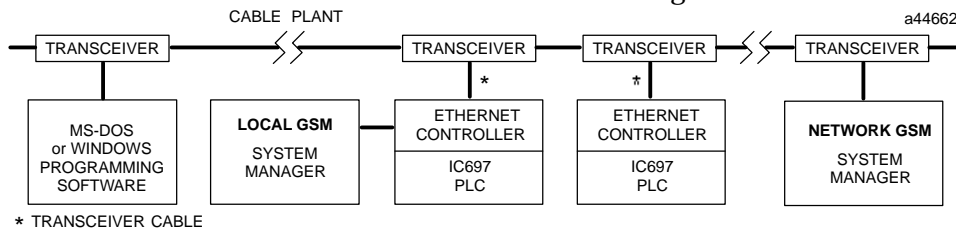

Figure 1. Ethernet Controller Connects the IC697 PLC to a 802.3 LAN

The Ethernet Controller is a member of the family of IC651 Factory LAN hardware and software products. The Factory LAN family of products provides high performance solutions for interconnecting automation controllers and for integrating them into multi-vendor networks.

The Ethernet Controller plugs into a single slot in an IC697 PLC rack and provides an 802.3-standard 15-pin D-connector for attachment of a user-supplied AUI (Attachment Unit Interface) or transceiver cable. The AUI cable connects to a user-supplied transceiver that is directly connected to the 10Mbps Ethernet network cable. The transceiver must be 802.3-compatible and must have the SQE option enabled.

Transceivers are commercially available to operate on a variety of 10Mbps media including thickwire coaxial cable (10Base5), ThinWire™ coaxial cable (10Base2), twisted pair (10BaseT), fiber optic (10BaseF), and broadband cable (10Broad36).

The Ethernet Controller is designed so the communications protocols which operate above the

Ethernet data link layer are implemented in software. This permits the user to choose between two* alternative communication protocols by downloading the Ethernet Controller with the applicable Communications Software:

- **TCP/IP-Ethernet Communications Software** - Communicate with host computers and/or MS-DOS or Windows Programmer using proprietary SRTP over a 4-layer TCP/IP (Internet) protocol stack; requires either a Local or Network Factory LAN System Manager (GSM) for configuration and downloading of Ethernet Controller software.
- **MMS-Ethernet Communications Software** - Communicate with host computers and/or MS-DOS or Windows Programmer using MMS (Manufacturing Message Specification - ISO 9506) on a 7-layer OSI protocol stack; requires GSM for configuration and downloading of Ethernet Controller software.

Figure 1 shows the general relationship between the Ethernet Controller, the local and network GSMs, and the MS-DOS or Windows Programming Software on Ethernet station.

* A third option, SRTP communications software (IC641SWP711) supports only communications with MS-DOS or Windows Programmers using SRTP over a 4-layer OSI protocol stack; this Ethernet Controller software does not require configuration and can be downloaded directly from the MS-DOS or Windows Programmer.

™ ThinWire is a trademark of Digital Equipment Corporation; ® IBM is a registered trademark of International Business Machines Corporation.
© MS-DOS, Windows, Windows 95, and Windows NT are registered trademarks of Microsoft Corporation.

GFK-0532K
August 1997

Ethernet Controller

Features of the Ethernet Controller

The Ethernet Controller is a single-slot module that is inserted directly into the IC697 CPU rack.

Connection to the Ethernet LAN is made via a transceiver cable to an external transceiver. The transceiver and cable are provided by the user. The transceiver is attached directly to the IEEE 802.3 network cable. The Ethernet Interface operates at 10 Mbps on the Ethernet LAN.

The Ethernet Controller uses three LEDs for indicating the status of the interface. A battery is provided to maintain the contents of Random Access Memory (RAM) over power outages.

The Ethernet Controller provides basic functions in firmware or Read Only Memory (ROM). This firmware includes self-test diagnostics and special software that allows you to configure and test your interface in the PLC and on the Ethernet LAN. It also allows you to load the communications software into RAM either from the GSM (serially or over the network), or from an MS-DOS or Windows OSI-Ethernet Programmer station.

The communications software is stored in RAM so you can upgrade communications software without replacing ROM chips. The battery maintains the contents of RAM over power outages.

“Soft Switches” are used to tailor the Ethernet Controller to your application. The MS-DOS or Windows Configuration Software package is used to configure the Ethernet Controller in the IC697 PLC, and to set the soft switches for the Ethernet Controller.

More detailed information about the Ethernet Controller, hardware installation, attachment to the Ethernet LAN, and Ethernet software follows this overview. For a complete description, refer to the User’s Manual that applies to the software you choose to run on it. These related publications are listed on page 8.

IEEE 802.3 Media

The Ethernet Controller can operate on any of the following media with the appropriate user-supplied transceiver cable and transceiver. IEEE 802.3 specifies the definitive requirements of each medium.

10Base5 Coax: 10Base5 uses a 0.4 inch diameter 50-ohm coaxial cable. The maximum length of a cable segment (single span of cable) is 500 meters. The distance between any two stations must be a multiple of 2.5 meters. A maximum of 100 stations is allowed on a thickwire Ethernet segment.

10Base2 Coax: 10Base2 uses a 0.2 inch diameter 50-ohm coaxial cable. The maximum length of a thinwire cable segment is 185 meters. A maximum of 30 stations is allowed on a thinwire Ethernet segment.

10BaseT: 10BaseT uses a twisted pair cable of up to 100 meters in length between each node and a hub or repeater. Typical hubs or repeaters support 6 to 12 nodes connected in a star wiring topology.

10BaseF: 10BaseF has two variations that both use the same type of fiber optic cable: 10BaseFP can support up to 33 nodes at distances of up to 500 meters from a passive star; 10BaseFL supports up to 2000 meters between a node and a repeater (a multi-port repeater would thus constitute a star). Additionally, 10BaseFB provides a means of interconnecting (only) repeaters by up to 2000 meters of (the same) fiber optic cable.

Note

Various Ethernet baseband media can be interconnected by appropriate repeaters. Capabilities and limitations are defined in IEEE 802.3 Chapter 13, “System Considerations for Multi-Segment Networks”.

10Broad36: 10Broad36 uses 75-ohm coaxial cable and CATV-like media components (taps, amplifiers, headend translators, etc.) to support hundreds of nodes at distances of up to 2800 meters. Broadband cannot be connected to baseband via repeaters. Broadband cable plant design and installation must be in accordance with IEEE 802.7 and requires special expertise. GE Fanuc recommends you contract professional specialists for these services. Consult your GE Fanuc sales representative or field service office for help in identifying local specialists.

Ethernet Controller

GFK-0532K
August 1997

Module Physical Description

Figure 2 shows the maintenance controls and indicators of the Ethernet Controller.

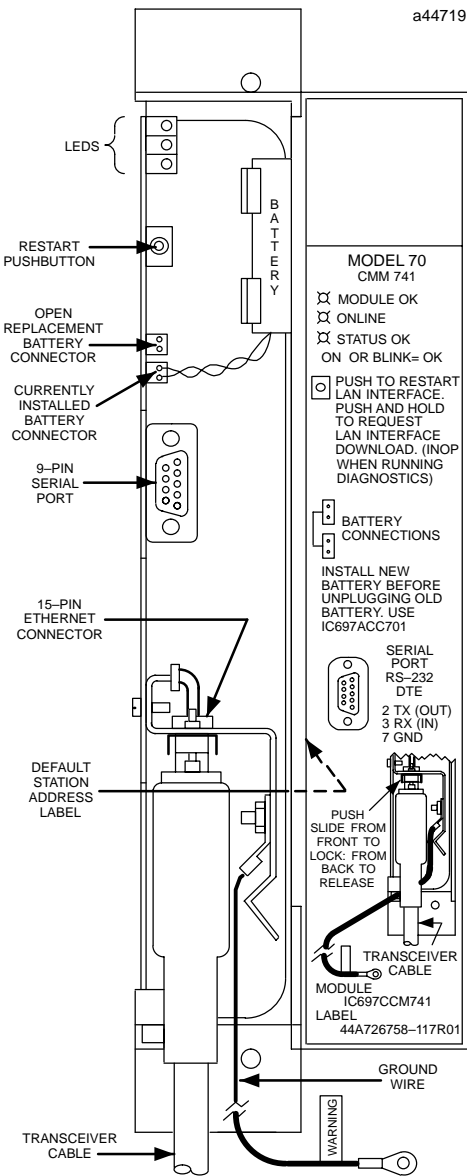

Figure 2. Ethernet Controller Board

User Maintenance Items

The Ethernet Controller has the following user-accessible elements:

- Three LEDs: located at the top front of the Ethernet Controller and are visible through a window in the front door.
- Default Station (MAC) Address Label: affixed on the outside of the plastic housing. This MAC station address is used for network communications, unless overridden by the user.
- Restart Button: located immediately below the LEDs.
- Battery and Battery Holder: located to the right of LEDs (between Restart button and serial port).
- Local Serial Port: 9-pin female connector for RS-232 Interface.
- AUI Port: 15-pin female connector with slide-lock for transceiver cable. Located beneath the local serial port.

Module Indicators

The Ethernet Controller board indicators consist of three Light Emitting Diodes (LEDs):

- MODULE OK
- ONLINE
- STATUS OK

See Figure 2 for LED location, and Table 1 for a description of these indicators.

Table 1. Ethernet Controller Indicators

Indicator	Status	Description
MODULE OK	ON	This LED is ON if the Ethernet Controller has passed diagnostics and its hardware is operating properly.
	OFF	It is OFF if the module fails a diagnostic test or if a fatal failure is detected while the board is running.
	BLINKING	This LED is blinking if the module is running diagnostics or is in Soft Switch entry state.
ONLINE	ON	This LED is ON when the Ethernet Controller is connected to and ready to communicate on the network.
	OFF	This LED is OFF when: <ul style="list-style-type: none"> - the station is not communicating in the network due to disconnection or a disruption of the cable. - the local station has malfunctioned. - the Ethernet Controller has been commanded not to enter the network or is in a state where network operation is inappropriate, such as Soft Switch Entry state or local loading.
	BLINKING	It is BLINKING when the module is transferring data on the network or loading over the network.
STATUS OK	ON	This LED is ON if the module is running without exception conditions.
	OFF	This LED is OFF if the module is running and detects an event that calls for supervisory attention. In this case you should connect the GSM and follow the instructions in Chapter 8 of the User's Manual to obtain further information.
	BLINKING	This LED is BLINKING if the module is loading or looking for a load source for the LAN Interfacesoftware.

Restart Button

The Restart button serves two functions: Restart, and Restart and Reload. The Restart button is inaccessible when the door to the Ethernet Controller is closed.

Restart: Pressing the Restart button (for less than 5 seconds) forces a restart of the Ethernet Controller. The power-up diagnostics run and the software on the module is restarted.

Restart and Reload: Pressing and holding the Restart button for 5 seconds or more requests a restart and reload of the Ethernet Controller. When the Restart button is pressed, all LEDs go out. After 5 seconds have elapsed, the STATUS OK LED will come ON to indicate that the Ethernet Controller will request a reload. Upon release of the button, the power-up diagnostics run and the Ethernet Controller requests a reload. See "Configuring and Loading the Ethernet Controller" for more information.

Note

Any data being transferred by the Ethernet Controller at the time of the Restart, or Restart and Reload, will be lost.

The Restart Button is not operable during the Ethernet Controller diagnostic phase. The Ethernet Controller is in diagnostic phase when the BOARD OK LED is BLINKING and the ONLINE and STATUS OK LEDs are OFF.

Battery

The battery and battery holder are located to the right of the LEDs. The battery connectors are located on the board between the Restart button and the 9-pin serial port connector.

When connected, the battery preserves the contents of RAM when there is no power to the board. The battery will maintain the RAM contents for a minimum of six months.

Ethernet Controller

GFK-0532K
August 1997

Local Serial Port

The 9-pin serial port (RS-232 interface) is used to connect locally to the Factory LAN System Manager (GSM) terminal. The communication software may be loaded through this port. The Ethernet Controller module is a Data Terminal Equipment (DTE) device. The pinouts of the port are shown in Table 2.

Table 2. RS-232 Port Pin Assignment

Pin	Signal	Description Number
2	TX	Transmit data (out)
3	RX	Receive data (in)
7	GND	Signal Ground

A cable is needed to connect the GSM to the Ethernet Controller. Figure 3 illustrates one type of GSM cable connection.

AUI Port

The 15-pin AUI port is located on the front bottom edge of the Ethernet controller board. This port connects the transceiver cable to the Ethernet Controller. The external 802.3 transceiver connects to the Ethernet network. Connector pinouts are shown in Table 3.

Caution

PLC power must be OFF when connecting or disconnecting the transceiver.

Note

Transceivers must be 802.3-compatible and must have the SQE option Enabled.

Table 3. Transceiver Port Pin Assignment

Pin	Signal	Description
1	GND	Signal Ground
2	CP+	Collision Presence +
3	TX+	Transmit +
4	GND	Signal Ground
5	RX+	Receive +
6	GND	Signal Ground
7	NC	Not Connected
8	GND	Signal Ground
9	CP-	Collision Presence -
10	TX-	Transmit -
11	GND	Signal Ground
12	RX-	Receive -
13	+12	+12 Volts
14	GND	Signal Ground
15	NC	Not Connected
Shell	PG	Protective Ground

Station Address Label

The Default Station (MAC) Address label lists the station address to be used by this module, unless a locally assigned address is set by the user via "Soft Switches". It is found on the right-hand outside of the plastic housing.

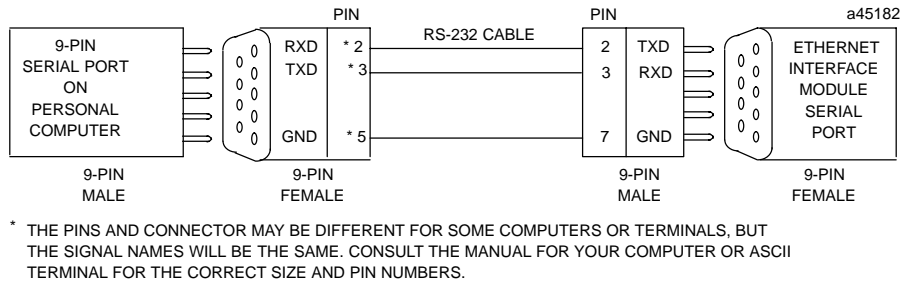

Figure 3. Cable to Connect the GSM to the Ethernet Interface

Installation

This section describes the physical installation of the Ethernet Controller into the IC697 PLC rack.

1. Read and record the 12-digit Default Station Address from the printed label on the Ethernet Controller.

A Station Configuration Data Form is provided in the User's Manual, for your convenience in recording the Station Configuration Information.

2. Be sure the IC697 PLC rack power is OFF.
3. Connect the Ethernet Controller battery:

Hold the module so the front cover is facing you with the hinge to the right. The tab on the battery cable should face to the right, away from the board surface.

Open the front cover of the Ethernet Controller module. The battery is mounted in the holder, but is not connected to the board. (See Figure 2.)

Connect the battery to either of the battery connectors on the card. Press down firmly to lock the battery connector in place.

4. Slide the Ethernet Controller into the slot for which it was configured in the system - normally the first available slot to the right of the CPU or Bus Transmitter Module (BTM). (See Figure 4. for the IC697 PLC rack layout)

Press firmly to lock the board in place, but do not force the board.

Note

The Ethernet Controller will not operate properly if there are empty slots to its left.

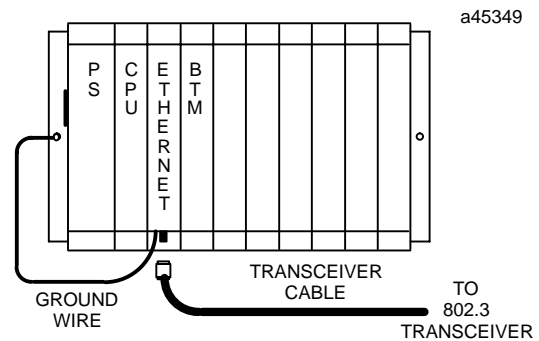

Figure 4. IC697 PLC Rack Layout

5. Connect the free end of the ground wire (18 inch long green wire attached to the Ethernet module) to the ground lug at the side of the IC697 PLC rack. (See Figure 4.)

Caution

The ground wire must be securely fastened to the chassis of the IC697 PLC rack and the rack must be properly grounded. Failure to do so may cause improper operation of the LAN.

Ethernet Controller

GFK-0532K
August 1997

- Connect the transceiver cable to the 15-pin AUI Port of the Ethernet Controller.

The other end of the transceiver cable should be connected to an external transceiver which is attached to the IEEE 802.3 network.

Warning

PLC power must be OFF when connecting or disconnecting the transceiver.

Note

Transceivers must be 802.3-compatible and must have the SQE option Enabled.

- Set the CPU Run/Stop switch to STOP.
- Power up the PLC rack.

Correct Results of Installation

During Power-Up: The MODULE OK LED on the front of the Ethernet Controller will BLINK during power-up diagnostics, and continue to BLINK while waiting for configuration data from the CPU.

After Power-Up: Once the Ethernet Controller has completed power-up diagnostics (about 15 seconds):

The MODULE OK LED will stop blinking, and should remain ON.

The ONLINE LED may be ON, OFF or BLINKING.

The STATUS OK LED will normally be BLINKING (unless software was previously loaded), indicating that the Ethernet Interface needs to be loaded.

If you get these indications, physical installation and power-up are complete. You may continue with Procedure 3 (or the next appropriate procedure) in Chapter 2 of the appropriate controller User's Manual.

Corrective Actions

MODULE OK OFF indicates a hardware fault, either in the Ethernet Controller or in the PLC, that prevents the Ethernet Controller from operating.

- Cycle power on the PLC to determine whether the fault is intermittent or a "hard" failure.

- If MODULE OK remains OFF, examine the PLC Fault Table for diagnostic information and take appropriate action. See the *IC697 Programmable Controller Installation and Operation Manual* for information on the PLC Fault Table.

For detailed troubleshooting information, refer to the applicable User's Manual.

Configuring and Loading the Ethernet Controller

As described earlier, the Ethernet Controller can be loaded with one of the alternative communications protocols. See Figure 5.

- TCP/IP Ethernet Communication Software.** If the Ethernet Controller must support TCP/IP communications to MS-DOS or Windows TCP/IP-Ethernet Programming software to other IC69* PLCs, CIM-PLICITY products, or Host Communications Drivers applications, you must create a configuration file on the Factory LAN System Manager (GSM) and download that file together with the TCP/IP communications software. The GSM software runs on a separate computer.
- MMS-Ethernet Communications Software.** If the Ethernet Controller must support MMS communications, you must create a configuration file on the Factory LAN System Manager (GSM) and download it together with the MMS communications software. The GSM is a separate computer running GSM software.

See the applicable user's manual for instructions on configuring and loading the Ethernet Controller. These operations are necessary before the LAN Interface can be used by your application.

Station Management Software

Operating a local area network entails certain LAN management activities. For the Factory LAN, this includes network performance measurement, fault diagnosis, configuration management, and downloading the appropriate configuration file and communication software to network nodes.

Many features to support these activities are built directly into the Ethernet Controller.

GFK-0532K
August 1997

Ethernet Controller

Nonetheless, certain occasional maintenance activities require that the user provide an external computer, such as a properly equipped IBM®-compatible personal computer.

The Ethernet Controller software includes the Factory LAN System Manager (GSM) to run on this external computer. The GSM is used to store on disk and to

download the communications software to the LAN Interface directly from the COM1 port on the GSM computer to the Ethernet Controller 9-pin serial port.

The System Manager (GSM) also supports node configuration and downloading across the LAN from a centralized location. A network GSM computer must include an appropriate Ethernet Interface.

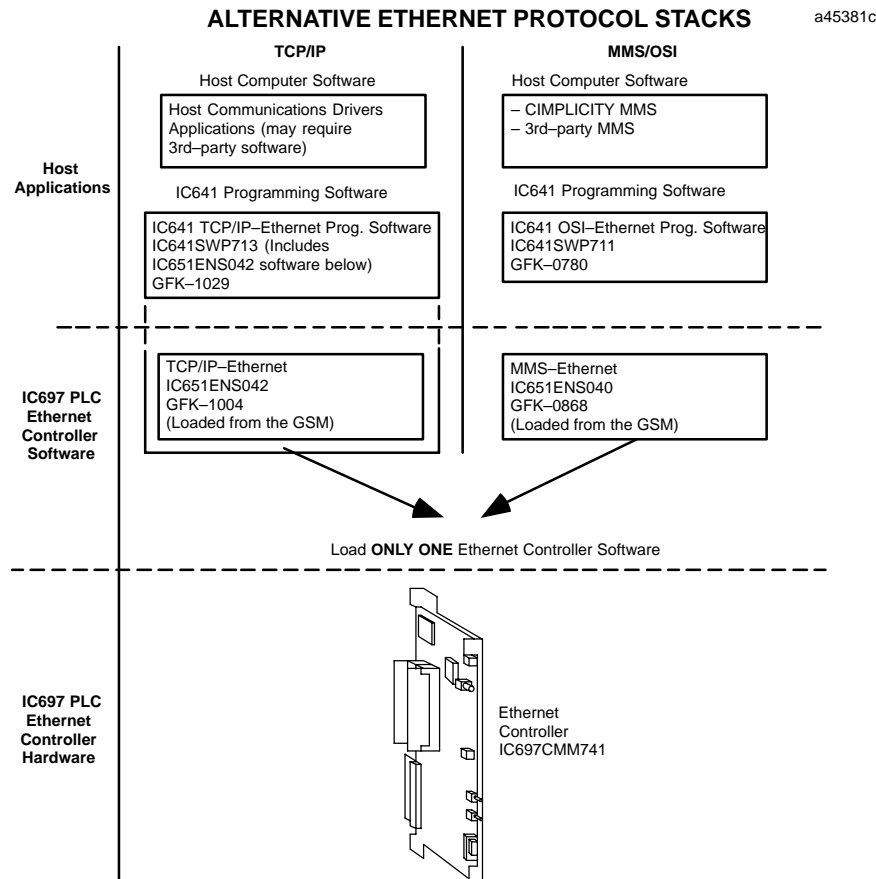

Figure 5. Alternative Ethernet Protocol Stacks for the IC697CMM741 Ethernet Controller

Related Publications (Factory LAN)

The following documents are related user documentation for the Factory LAN family of communication products.

- *TCP/IP-Ethernet Communications User's Manual*
- *MMS-Ethernet Communications User's Manual*
- *PLC Programmer TCP/IP-Ethernet User's Manual*
- *PLC Programmer-Ethernet User's Manual*
- *PLC Programming Software User's Manual*
- *Programmable Controller Reference Manual*
- *Programmable Controller Installation Manual*
- *Host Communications Toolkit C/C++ and Visual Basic User's Manual*
- *Host Communications Drivers for Microsoft Windows User's Manual*
- *TCP/IP Windows 95/Windows NT User's Manual Supplement*

Ethernet Controller

GFK-0532K
August 1997

Table 4. Module Specifications †

Power Consumption (Typical):	Power consumption for the Ethernet Controller includes external RS-232 loads and the external transceiver. The module is powered by the rack. The power supply must provide +12 Vdc. $\frac{+5 \text{ Vdc}}{1.00 \text{ A}} \quad \frac{+12 \text{ Vdc}}{0.5 \text{ A}}$
Memory Retention:	An on-board battery provides backup power (at least 6 months) when power is removed from the CPU rack containing the Ethernet Controller.
Physical Dimensions: Circuit Board: Mounting:	6.3 x 9.19 inches (160 x 233 mm). Occupies a single slot in an IC697 PLC rack. The module plugs into the IC697 CPU rack in the first available slot to the right of the CPU or BTM. (Bus Receiver Module if remote rack)
Connectors:	- LED Indicators: MODULE OK, ONLINE, STATUS OK - Restart pushbutton and Battery connectors - front edge of board behind the hinged door Serial and Transceiver Ports - Serial Port: 9-pin female, D-connector (to Local GSM) - Transceiver Port: 15-pin female, D-connector (to Ethernet transceiver cable and network)
Interface Specifications:	LAN (to Network GSM and/or IC641-Ethernet Programmer) IEEE 802.2 Logical Link Control Class I IEEE 802.3 CSMA/CD Medium Access Control 10Mbps Serial Port: RS-232 DTE, 9600 bps Transceiver Port: Ethernet, IEEE 802.3 CSMA/CD, Transceiver SQE must be Enabled.

† Refer to GFK-0867B, or later for product standards and general specifications. For installations requiring compliance to more stringent requirements (for example, FCC or European Union Directives), refer to *Installation Requirements for Conformance to Standards*.

Table 5. Ordering Instructions

Ethernet Controller	Ethernet Controller Module	IC697CMM741
TCP/IP Ethernet Controller Software	TCP/IP Software and Documentation for the PLC Ethernet Controller (Includes GSM).	IC651ENS042
TCP/IEthernet Programming Software and LAN Interface Software (MS-DOS version) (Windows version)	Software and Documentation for the IC641-TCP/IEthernet Programmer and Software and Documentation for the IC697 PLC (Includes IC651ENS042). TCP/IP Windows®95/Windows NT® MS-DOS® Box version of above.	IC641SWP713 IC641SWC716
MMS/OSI Ethernet Controller Software	MMS Software and Documentation for the PLC Ethernet Controller (Includes GSM).	IC651ENS040
OSI-Ethernet Programming Software	Software and Documentation for the IC641 OSI-Ethernet Programmer which includes SRTP-Ethernet software and documentation.	IC641SWP711

Note: For Conformal Coat option, or Low Temperature Testing option please consult the factory for price and availability.

Replacement Parts

PLC Power Supply	120/240 VAC or 125 VDC Input, 100 watt Power Supply 24 VDC Input, 90 watt Power Supply 48 VDC Input, 90 watt Power Supply (One of these Power Supplies is a prerequisite, since +5 Vdc and +12 Vdc are required by the Ethernet Controller Module)	IC697PWR711 IC697PWR724 IC697PWR748
Battery	Lithium Battery, 3V, to protect LAN Controller memory from power loss	IC697ACC701

GFK-1309E
September 1998

Ethernet Interface (Type 2)

a45632

Features

- Connects IC697 PLC to an IEEE 802.3 CSMA/CD 10Mbps Ethernet LAN via one of three network ports: 10BaseT, 10Base2, or AUI
- 10BaseT and 10Base2 network ports provide direct connection to 10BaseT or 10Base2 network without an external transceiver
- Standard 15-pin AUI network port allows choice of 10Base5, 10Base2, 10BaseT, 10BaseF, or 10Broad36 medium with user-supplied 802.3-compatible transceiver
- Firmware is pre-loaded for easy installation and is maintained indefinitely; firmware is easily upgraded in-system from PC attached to RS-485 serial port
- The Ethernet Interface provides:
 - Data exchange using configuration-based and logic-based Ethernet Global Data
 - TCP/IP communications services using SRTP
 - Full PLC programming and configuration services
 - Comprehensive station management and diagnostic tools

Functions

The IC697CMM742 Ethernet Interface (Type 2) provides high performance TCP/IP communications for the IC697 PLC.

The Ethernet Interface (Type 2) plugs into a single slot in an IC697 PLC rack and is configured with the IC641 PLC programming software. Up to four Ethernet Interface (Type 2) modules can be installed in an IC697 PLC CPU rack.

The Ethernet Interface (Type 2) contains three network ports: 10BaseT (RJ-45 connector), 10Base2 (BNC connector), and AUI (15-pin D-connector). The Ethernet Interface automatically selects the network port in use. One network port may be used at a time.

The 10BaseT network port permits direct connection to a 10BaseT (twisted pair) network hub or repeater without an external transceiver.

The 10Base2 network port permits direct connection to a 10Base2 (ThinWire™) network without an external transceiver.

The AUI network port permits attachment of a user-supplied AUI (Attachment Unit Interface, or transceiver) cable.

™ ThinWire is a trademark of Digital Equipment Corporation.

© MS-DOS, Windows, Windows95, and Windows NT are registered trademarks of Microsoft Corporation.

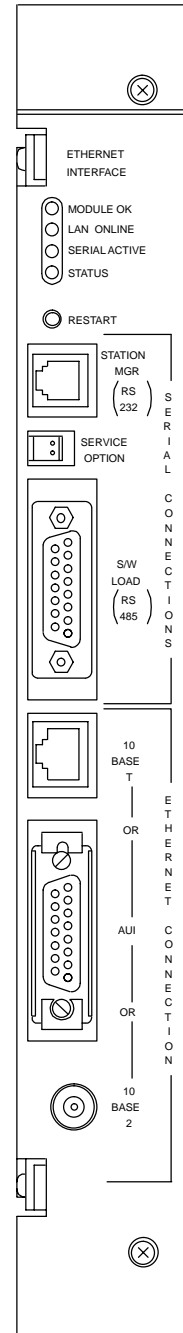

The AUI cable connects the Ethernet Interface to a user-supplied transceiver that is directly connected to the 10Mbps Ethernet network. The transceiver must be 802.3 compatible and must have the SQE option enabled.

GFK-1309E
September 1998

Ethernet Interface (Type 2)

Transceivers are commercially available to operate on a variety of 10Mbps media including 0.4 inch diameter coaxial cable (10Base5), ThinWire coaxial cable (10Base2), twisted pair (10BaseT), fiber optic (10BaseF), and broadband cable (10Broad36).

The Ethernet Interface (Type 2) provides TCP/IP communications with other IC697 and IC693 PLCs, host computers running the Host Communications Toolkit or

CIMPLICITY® software, and computers running the TCP/IP version of the MS-DOS or Windows based programming software. These communications use the proprietary SRTP and Ethernet Global Data protocols over a 4-layer TCP/IP (Internet) stack.

Figure 1 shows the IC697 PLC in a basic Ethernet communication system.

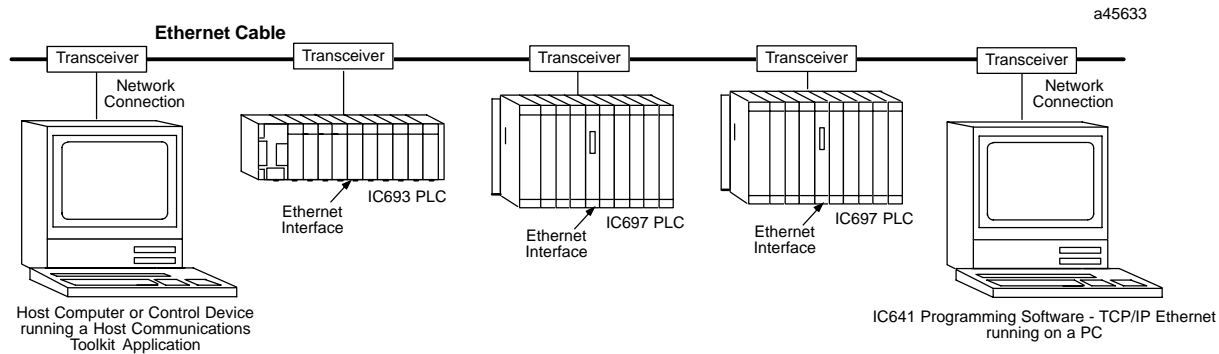

Figure 1. Ethernet Interface Connects the IC697 PLC to an 802.3 LAN

IEEE 802.3 Media

The Ethernet Interface (Type 2) can operate directly on 10BaseT or 10Base2 media via its 10baseT and 10Base2 network ports. These media are described below. Additionally, the Ethernet Interface (Type 2) can operate on any of the media listed below with the appropriate user-supplied transceiver and transceiver cable via its AUI network port.

10Base5 Coax: 10Base5 uses a 0.4 inch diameter 50-ohm coaxial cable. The maximum length of a cable segment (single span of cable) is 500 meters. The distance between any two stations must be a multiple of 2.5 meters. A maximum of 100 stations is allowed on a thickwire Ethernet segment.

10Base2 Coax: 10Base2 uses a 0.2 inch diameter 50-ohm coaxial cable. The maximum length of a ThinWire cable segment is 185 meters. A maximum of 30 stations is allowed on a ThinWire Ethernet segment.

10BaseT: 10BaseT uses a twisted pair cable of up to 100 meters in length between each node and a hub or repeater. Typical hubs or repeaters support 6 to 12 nodes connected in a star wiring topology.

10BaseF: 10BaseF has two variations that both use the same type of fiber optic cable: 10BaseFP can support up

to 33 nodes at distances of up to 500 meters from a passive star; 10BaseFL supports up to 2000 meters between a node and a repeater (a multi-port repeater would thus constitute a star). Additionally, 10BaseFB provides a means of interconnecting (only) repeaters by up to 2000 meters of (the same) fiber optic cable.

Note

Various Ethernet baseband media listed above can be interconnected by appropriate repeaters. Capabilities and limitations are defined in IEEE 802.3 Chapter 13, *System Considerations for Multi-Segment Networks*.

10Broad36: 10Broad36 uses 75-ohm coaxial cable and CATV-like media components (taps, amplifiers, headend translators, etc.) to support hundreds of nodes at distances of up to 2800 meters. Broadband cannot be connected to baseband via repeaters. Broadband cable plant design and installation must be in accordance with IEEE 802.7 and requires special expertise. GE Fanuc recommends you contract professional specialists for these services. Consult your local authorized GE Fanuc PLC distributor, or your GE Fanuc sales representative or field service office for help in identifying local specialists.

Ethernet Interface (Type 2)

GFK-1309E
September 1998

Physical Description

Figure 2 shows the maintenance items and indicators of the Ethernet Interface (Type 2).

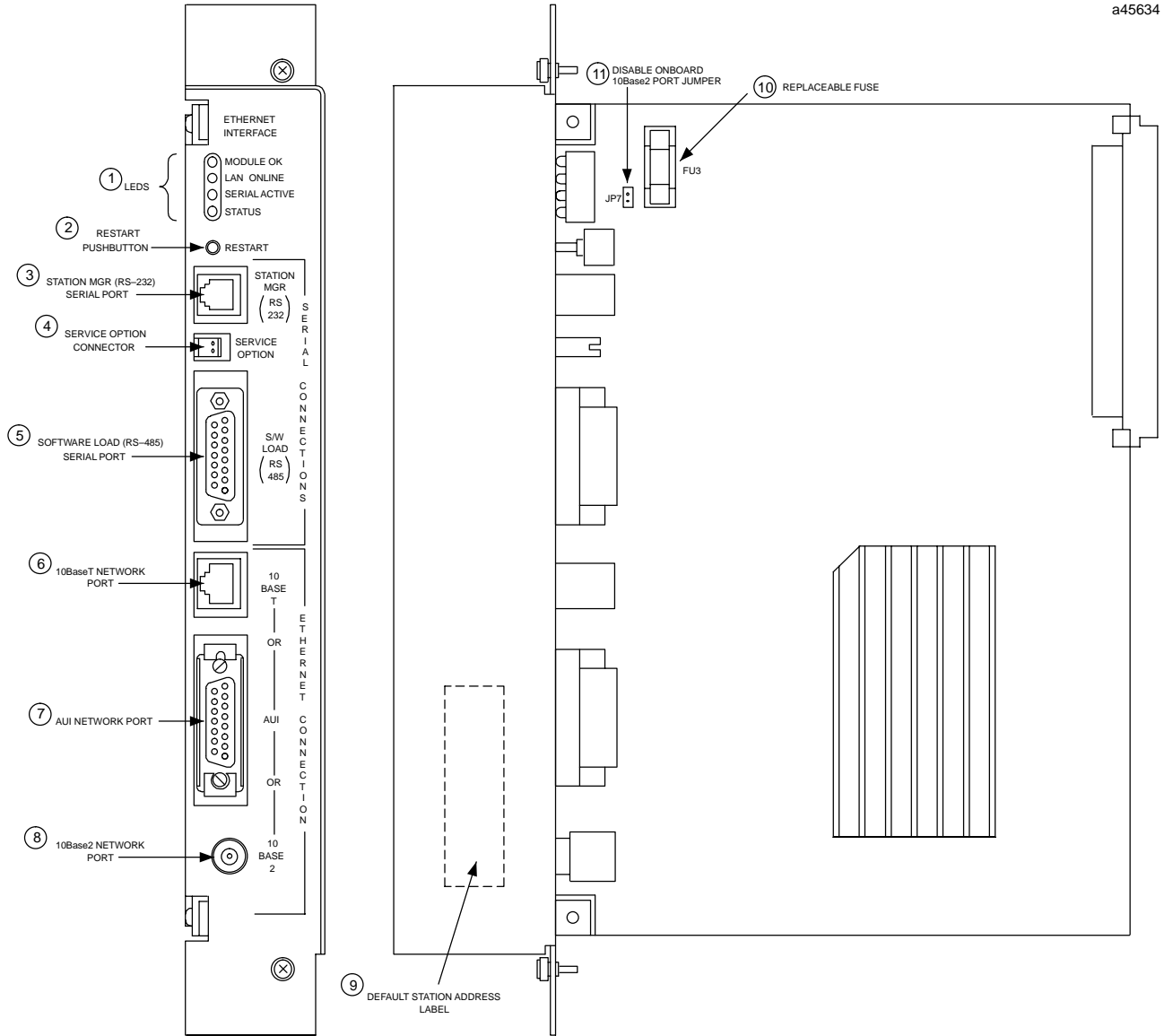

Figure 2. Ethernet Controller Board

User Maintenance Items

The Ethernet Interface has the following user-accessible elements:

1. Four LEDs
2. Restart Pushbutton
3. Station Mgr (RS-232) Serial Port
4. Service Option Connector
5. Software Load (RS-485) Serial Port
6. 10BaseT Network Port
7. AUI Network Port
8. 10Base2 network Port
9. Default Station (MAC) Address Label (located on the inside edge of the module faceplate)
10. Replaceable +12 VDC Fuse (FU3)
11. Onboard 10base2 Transceiver Power Disable Jumper (JP7 - normally not installed)

GFK-1309E
September 1998

Ethernet Interface (Type 2)

Module Indicators

The Ethernet Interface board indicators consist of four Light Emitting Diodes (LEDs):

- MODULE OK
 - LAN ONLINE
 - SERIAL ACTIVE
 - STATUS
- Refer to Figure 2 for the location of the LED indicators, and Table 1 for a description of the indicators.

Table 1. Ethernet Interface (Type 2) LED Indicators

Indicator	Status	Description
MODULE OK	ON	This LED is <i>ON</i> if the Ethernet Interface has passed diagnostics and is operating properly.
	OFF	This LED is <i>OFF</i> if the module fails a diagnostic test, or if a fatal failure is detected during operation.
	BLINKING	This LED is <i>BLINKING</i> during diagnostics, or to indicate special operating conditions. *
LAN ONLINE	ON	This LED is <i>ON</i> when the Ethernet Interface is connected to the Ethernet network and is ready to communicate.
	OFF	This LED is <i>OFF</i> when: - the Ethernet Interface is not communicating in the network due to disconnection or disruption of the cable. - the Ethernet Interface has malfunctioned. - the Ethernet Interface has been commanded not to enter the network.
	BLINKING	This LED is <i>BLINKING</i> when the Ethernet Interface is transferring data on the network or, to indicate special operating conditions. *
SERIAL ACTIVE	OFF	This LED is <i>OFF</i> during inactivity at the RS-485 serial port.
	BLINKING	This LED is <i>BLINKING</i> during data transfer at the RS-485 serial port, or to indicate special operation conditions. *
STATUS OK	ON	This LED is <i>ON</i> when the module is operating without exception conditions.
	OFF	This LED is <i>OFF</i> if the Ethernet Interface detects an event (exception condition) during operation that requires supervisory attention. In this case, refer to the PLC Fault Table for further information, as described in the <i>Troubleshooting</i> chapter of the User's manual.
	BLINKING	This LED is <i>BLINKING</i> during special operating conditions. *

*Special operating conditions are indicated by multiple LEDs blinking in unison:

- During the *Software Load* state, all LEDs blink in unison.
- During the *Waiting for IP Address* state, the MODULE OK and STATUS LEDs blink in unison.
- During the *Maintenance* state, the MODULE OK and SERIAL ACTIVE LEDs blink in unison.

Restart Pushbutton

The Restart button serves four functions: LED test, restart, restart and enter Software Load state, and restart and enter Maintenance state. These four functions behave similarly in all states except for the Software Load state. While in this state, pressing the pushbutton will cause an immediate restart into the Operational state (without performing the LED test) if the software in the Ethernet Interface has not been corrupted or erased. If the software has been corrupted or erased, pressing the pushbutton will cause an immediate restart back into the Software

Load state. Use a pointed tool to press the Restart pushbutton.

LED Test: Any time the Restart pushbutton is released *all* the LEDs flash ON. You should visually verify that all the LEDs go OFF and ON at this time. Then the Interface performs either a restart, a restart and enter Software Load state, or a restart and enter Maintenance state, depending on the duration that you press the pushbutton.

Restart: Pressing the Restart pushbutton momentarily (less than 5 seconds) requests a restart of the Ethernet Interface. When the Restart pushbutton

Ethernet Interface (Type 2)

GFK-1309E
September 1998

is pressed, all LEDs go out. When it is released, all LEDs flash ON, then power-up diagnostics run, and the software on the Interface is restarted into the Operational state.

Restart and Enter Software Load State: Pressing and holding the Restart pushbutton until the bottom LED (STATUS) turns ON (between 5 and 10 seconds) forces a restart and requests entrance to the Software Load state. A reload is used to install a software update into the module and is not part of normal operation. When the Restart pushbutton is pressed, all LEDs go out. After approximately 5 seconds have elapsed, the STATUS LED (bottom LED) comes ON, to indicate that the Ethernet Interface will request a reload. After the Restart pushbutton is released, all LEDs flash ON, then power-up diagnostics run, and the Ethernet Interface waits for the software load with all LED's blinking in unison.

Restart and Enter Maintenance State: Pressing and holding the Restart pushbutton until the bottom two LEDs turn ON (approximately 10 seconds) forces a restart and requests entrance to the Maintenance state. After approximately 5 seconds, the STATUS LED comes ON, then after approximately a total of 10 seconds have elapsed, the SERIAL ACTIVE LED also comes ON, to indicate that the Ethernet Interface will request entry to the Maintenance state. After the Restart pushbutton is released, all LEDs flash ON, power-up diagnostics run and the Ethernet Interface enters the Maintenance state.

Note

Any data being transferred by the Ethernet Interface at the time of the Restart will be lost.

The Restart pushbutton is not operable during the diagnostic phase of power-up. The Ethernet Interface is in the diagnostic phase when the MODULE OK LED is BLINKING and the other LEDs are OFF.

Service Option Connector

If a problem occurs with the Ethernet Interface that requires removal from the PLC rack, the onboard exception log will be preserved for 2 to 3 days. The Service Option connector allows you to attach a 3 volt Lithium battery (IC697ACC701) to save the exception log contents for longer periods.

Station Mgr (RS-232) Serial Port

The 6-pin RJ-11 *phone jack* RS-232 serial port is used to connect a terminal or terminal emulator to access the Station Manager software on the Ethernet Interface. The pin assignments for this connector are shown in Table 2.

Table 2. Station Mgr (RS-232) Port Pin Assignment

Pin Number	Signal	Description
1	CTS	Clear to Send (input)
2	TD	Transmit Data (output)
3	SG	Signal Ground
4	SG	Signal Ground
5	RD	Receive Data (input)
6	RTS	Request to Send (output)

Use the available serial cable (IC693CBL316) to connect a terminal or PC to the Station Mgr (RS-232) serial port. Refer to Appendix B of the User's manual for more information.

Software Load (RS-485) Serial Port

The 15-pin D-type RS-485 serial port is used to connect a PC running the PC Software Loader software to the Ethernet Interface in order to update the firmware in the Ethernet Interface. The pin assignments for this connector are shown in Table 3.

Table 3. Software Load (RS-485) Port Pin Assignment

Pin Number	Signal	Description
1	Shield	
2	NC	No Connection
3	NC	No Connection
4	NC	No Connection
5	+5V *	+5V power for RS-232/RS-485 converter
6	RTS (A)	Request to Send (output)
7	Signal Ground	Signal Ground, 0V
8	CTS (B')	Clear to Send (input)
9	RT *	Terminating Resistor for RD **
10	RD (A')	Receive Data (input)
11	RD (B')	Receive Data (input)
12	SD (A)	Send Data (output)
13	SD (B)	Send Data (output)
14	RTS (B)	Request to Send (output)
15	CTS (A')	Clear to Send (input)

GFK-1309E
September 1998

Ethernet Interface (Type 2)

Use and RS-232/RS-485 adapter to connect systems that provide an RS-232 interface to the Software Load (RS-232) serial port on the Ethernet Interface.

Catalog number IC690ACC900 is an RS-232/RS-485 converter; Miniconverter Kit IC690ACC901 also contains an RS-232/RS-485 converter. Refer to Appendix B of the User's Manual for more information.

10BaseT Network Port

The 8-pin RJ-45 *phone jack* 10BaseT network port is used to connect a twisted-pair cable from a 10BaseT hub or repeater directly to the Ethernet Interface without an external transceiver. The pin assignments for this connector are shown in Table 4.

Table 4. 10BaseT Network Port Pin Assignment

Pin Number	Signal	Description
1	TD+	Transmit Data+ (output)
2	TD-	Transmit Data - (output)
3	RD+	Receive Data+ (input)
4	NC	No Connection
5	NC	No Connection
6	RD-	Receive Data- (input)
7	NC	No Connection
8	NC	No Connection

AUI Port

The 15-pin AUI network port connects the transceiver cable to the Ethernet Interface. The external 802.3 transceiver connects to the Ethernet network. Connector pin assignments are shown in Table 5.

Caution

PLC power must be OFF when connecting or disconnecting the transceiver.

Note

Transceivers must be 802.3-compatible and must have the SQE option Enabled.

Replaceable +12 VDC Fuse

A replaceable fuse is available on the +12 VDC power that is supplied by this module to the AUI port to power external transceivers.

Table 5. AUI Port Pin Assignment

Pin	Signal	Description
1	GND	SignalGround
2	CP+	CollisionPresence +
3	TX+	Transmit +
4	GND	SignalGround
5	RX+	Receive +
6	GND	SignalGround
7	NC	No Connection
8	GND	SignalGround
9	CP-	CollisionPresence -
10	TX-	Transmit -
11	GND	SignalGround
12	RX-	Receive -
13	+12	+12 Volts
14	GND	SignalGround
15	NC	No Connection
Shell	PG	ProtectiveGround

10Base2 Network Port

The BNC 10Base2 network port is used to connect a 10Base2 (ThinWire) network directly to the Ethernet Interface without an external transceiver. The 10Base2 network cables are attached to the Ethernet Interface with a T or F BNC connector.

Onboard 10Base2 Port Transceiver Power Disable Jumper

This jumper must be in place to ensure proper network operation when using an external transceiver connected to the AUI port that is *externally* powered.

Default Stations Address Label

The Default Station (MAC) Address label lists the station address to be used by this module, unless a locally assigned address is set by the user via the Station Manager. It is found on the inside edge of the protruding flange of the module faceplate. The Default Station Address label is visible when the Ethernet Interface module is inserted in the PLC rack.

Ethernet Interface (Type 2)

GFK-1309E
September 1998

Installation

This section describes the physical installation of the Ethernet Interface into the IC697 PLC rack. The installation process is completely described in the *Installation* chapter of the User's Manual.

1. Read and record the 12-digit Default Station Address from the printed label on the Ethernet Interface.

A Station Configuration Data Form is provided in the User's Manual, for your convenience in recording the Station Configuration Information.

2. Be sure the IC697 PLC rack power is OFF.
3. Slide the Ethernet Interface into the slot for which it was configured in the system - normally the first available slot to the right of the CPU or Bus Transmitter Module (BTM)

Press the board firmly in place, but do not force the board. Tighten the screws on the top and bottom tabs.

Note

The Ethernet Controller will not operate properly if there are empty slots to its left.

4. Connect **one** of the network ports on the Ethernet Interface to the Ethernet network. If you are using an external transceiver, connect the transceiver cable to the AUI port on the Ethernet Interface. The other end of the transceiver cable should be connected to an external IEEE 802.3 compatible transceiver that is connected to the Ethernet network.

Warning

PLC power must be OFF when connecting or disconnecting the transceiver.

Note

Transceivers must be 802.3-compatible and must have the SQE option Enabled.

Note

When using an external transceiver that is **externally** powered (that is, it does not require +12 VDC current from the AUI port), the *Disable Onboard 10Base2 Port* jumper must be in place to ensure proper network operation.

5. Set the CPU Run/Stop switch to STOP.
6. Power up the PLC rack.

Configuring the Ethernet Interface

Essential network addresses for each Ethernet Interface are setup by the MS-DOS® or Windows® PLC Configuration Software and stored to the PLC. These addresses *must be properly configured* before the Ethernet Interface can be used by your application. The configuration process is completely described in Procedure 2 in the *Installation* chapter of the User's Manual.

Powering-Up the Ethernet Interface

After the Ethernet Interface has been properly configured, turn power OFF to the PLC rack for 3 to 5 seconds, then turn power back ON.

During Power-Up:

The MODULE OK LED on the Ethernet Interface will BLINK while the Interface performs power-up diagnostic tests, and continue to blink while waiting for configuration data from the PLC CPU.

After Power-Up:

The MODULE OK LED should stop blinking, and should remain ON.

The LAN LED may be ON, OFF, or BLINKING - depending upon network activity.

The STATUS LED should be ON, indicating no exception conditions.

The LED indications described above indicate that the Ethernet Interface is ready for use.

GFK-1309E
September 1998

Ethernet Interface (Type 2)

Corrective Actions:

If the MODULE OK LED is OFF, a hardware fault has occurred, either in the Ethernet Interface or in the PLC, that prevents the Ethernet Interface from operating. Refer to the *Installation and Troubleshooting* chapters of the User's Manual for detailed troubleshooting information.

If the MODULE OK LED is ON, but the STATUS LED is OFF, an operational problem has occurred. Refer to the *Troubleshooting* chapter of the User's Manual for detailed troubleshooting information.

Station Management

Operating a local area network entails certain LAN management activities such as network performance measurement, status information, and fault diagnosis.

The Ethernet Interface contains many features to support these activities. Some of these features are accessed via the Station Manager, a portion of the Ethernet Interface operating firmware that responds to user commands. The Station Manager operates locally via an ASCII terminal or terminal emulator connected to the Station Mgr (RS-232) serial port, or remotely over the Ethernet LAN. Refer to the *TCP/IP Ethernet Communications Station Manager Manual* for complete information on the Station Manager.

Related Publications (Factory LAN)

The following documents are related user documentation for the Factory LAN family of communication products.

- *TCP/IP Ethernet (Type 2) Communications User's Manual*
- *TCP/IP Ethernet Communications Station Manager Manual*
- *PLC Programming Software User's Manual*
- *PLC Programmer TCP/IP Ethernet User's Manual Supplement*
- *PLC Programmer TCP/IP Windows[®] 95/Windows NT[®] User's Manual Supplement*
- *Programmable Controller Reference Manual*
- *Programmable Controller Installation Manual*
- *Host Communications Toolkit C/C++ and Visual Basic User's Manual*
- *Host Communications Drivers for Microsoft Windows User's Manual*

Ethernet Interface (Type 2)

GFK-1309E
September 1998

Table 6. Specifications for IC697CMM742 †

<p>General Specifications:</p> <p>Module Operating Voltage</p> <p>Module Current Drain</p> <p>Module Operating Temperature</p> <p>LED Indicators</p> <p>Connectors</p> <p>Fuse, Replaceable</p>	<p>+5 VDC, +12 VDC (from PLC power supply)</p> <p>2.0 Amps (+5 VDC), typical 0.5 Amps (+12 VDC), maximum when powering an external AUI transceiver</p> <p>0° C to +55°C (32°F to 131°F), ambient</p> <p>MODULE OK LAN ONLINE SERIAL ACTIVE STATUS</p> <p>– Station Manager (RS-232) Port: 6-pin female RJ-11 – Software Load (RS-485) Port: 15-pin female D-connector – 10BaseT Port: 8-pin female RJ-45 – AUI Port: 15-pin female D-connector with slide-lock – 10Base2 port: female BNC connector</p> <p>5 x 20mm, 250V, 1.0A, slow acting</p>
<p>Interface Specifications:</p> <p>LAN</p> <p>Serial Ports</p> <p>Network Ports</p>	<p>IEEE 802.2 Logical Link Control Class I IEEE 802.3 CSMA/CD Medium Access Control 10Mbps</p> <p>Station Mgr Port: RS-232 DTE 300 - 19200 bps Software Load Port: RS-485 DTE 300 - 19200 bps</p> <p>10BaseT Port: Ethernet, IEEE 802.3 CSMA/CD 10Base2 Port: Ethernet, IEEE 802.3 CSMA/CD AUI Port: Ethernet, IEEE 802.3 CSMA/CD (transceiver SQE must be enabled)</p>

† Refer to GFK-0867B, or later for product standards and general specifications. For installations requiring compliance to more stringent requirements (for example, European Union), refer to *Installation requirements for Conformance to Standards*.

Table 7. Ordering Instructions

Description	Catalog Number
Ethernet Interface (Type 2) for IC697 PLC (includes User's Manual)	IC697CMM742
[Optional]: Station Manager cable for Ethernet Interface (includes Station Manager Manual)	IC693CBL316
[Optional]: PLC Programmer TCP/IP Ethernet (MS-DOS Version)	IC641SWC713 or IC641SWM713
PLC Programmer TCP/IP Ethernet (Windows Version)	IC641SWC716 or IC641SWM716

Note: For Conformal Coat option, or Low Temperature Testing option please consult the factory for price and availability.

Table 8. Required PLC Power Supplies (with +12 VDC Output)

Description	Catalog Number
IC697 PLC Power Supply: 120/240 VAC or 125 VDC Input, 55 watt (only if AUI port not in use)	IC697PWR710
IC697 PLC Power Supply: 120/240 VAC or 125 VDC Input, 100 watt	IC697PWR711
IC697 PLC Power Supply: 24 VDC Input, 90 watt	IC697PWR724
IC697 PLC Power Supply: 48 VDC Input, 90 watt	IC697PWR748

Communications Modules

IC697CMM712

GFK-1039B
August 1997

Serial Communications Module for State Logic CPU

Features

- Single slot Serial Communications for State Logic CPU
- No programming required
- CCM2 Protocol (slave only)
- 12 Mhz, 80C186 microprocessor
- Two RS-422/RS-485 or RS-232 serial ports
- Reset pushbutton
- One Status LED
- Soft Configuration (No dip switches or jumpers) using IC641 (MS-DOS) programming software configuration function
- Simultaneous communications on both ports at up to 19.2 Kbaud
- Provides Serial Communications for State Logic Control System
- All necessary memory supplied with module

Functions

The Serial Communications Module (SCM) provides I/O ports for serial communications to the State Logic Control System. The State Logic CPU control system program uses the SCM to receive input from a serial device and to transmit information to a serial device.

Each module provides two ports that may each be configured to be RS-232 or RS-422/RS-485 ports. The State Logic Control System supports up to four Serial Communications Modules providing a capacity of a total of eight serial ports. The Serial Communications Modules are inserted in slots 2 through 5 of rack 0.

One of the eight ports may be a CCM2 port. An expanded form of the CCM2 protocol is supported providing read/write capability for analog input and output values, %M internal flags, and current States of Tasks, in addition to the normal discrete inputs and outputs, and variable values. Additional functionality is provided for custom CCM communication programs.

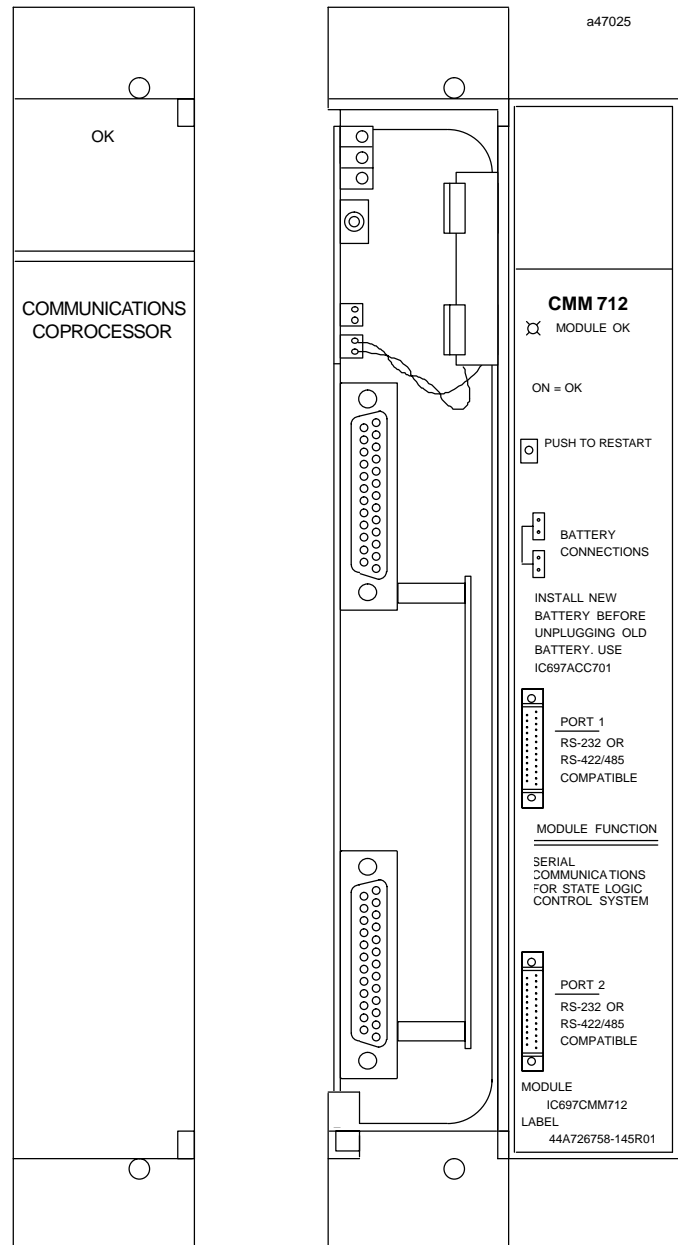

© MS-DOS is a registered trademark of Microsoft Corporation.

GFK-1039B
August 1997

Serial Communications Module for State Logic CPU

Installation

- Installation should not be attempted without referring to the applicable *Programmable Controller Installation Manual* (see reference 3) and *State Logic Control System User's Manual* (see reference 1).
- Make sure rack power is off.
- Connect the battery to either of the battery connectors on the module. (See Figure 2)
- Install in slots 2 through 5 of rack 0 (see Figure 1).
- Turn on power.

The module should power up and blink the top LED. When the diagnostics have completed successfully the top LED stays on.

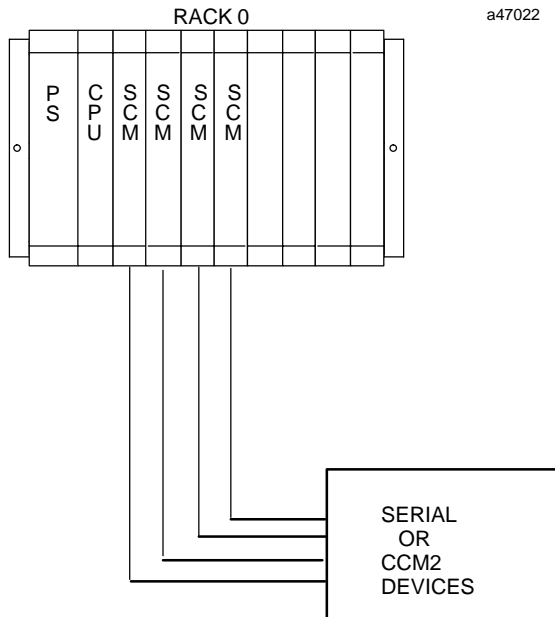

Figure 1. Typical PLC System Configuration

Memory

The Serial Communications Module does not require a memory expansion daughter board. All necessary memory is provided with the module.

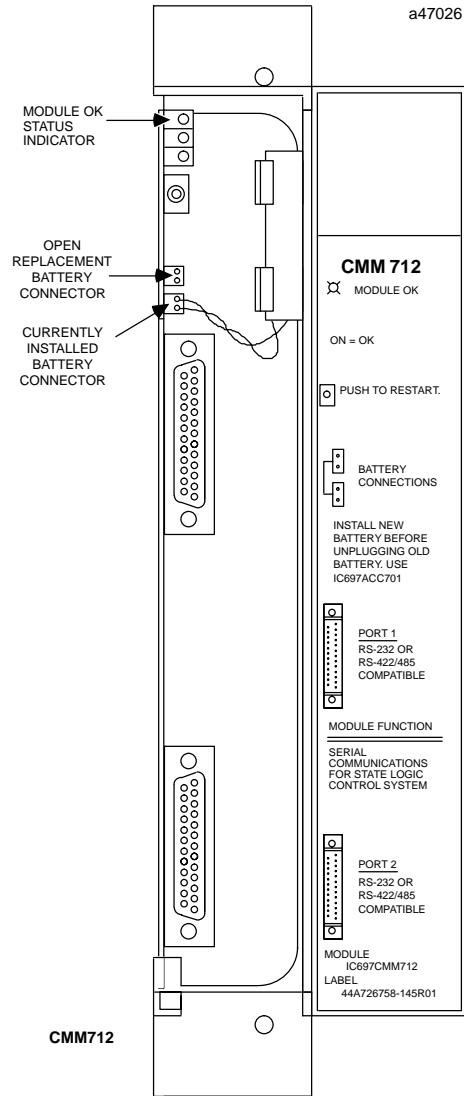

Figure 2. Serial Communications Module User Details

Serial Communications Module for State Logic CPU

GFK-1039B
August 1997

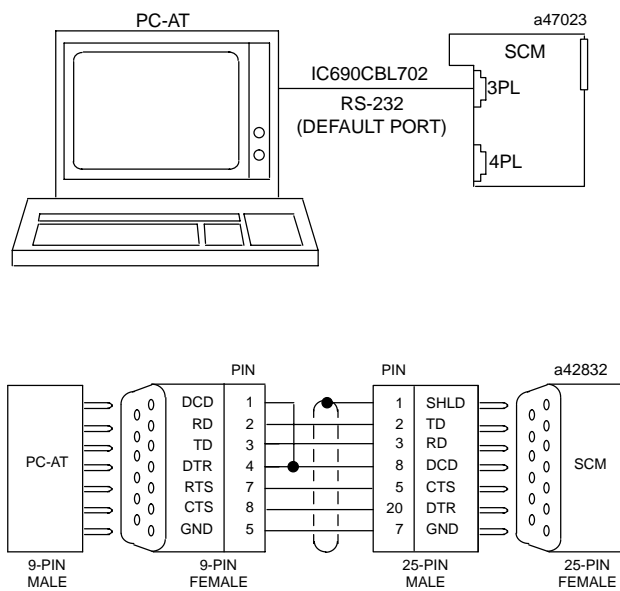

Figure 3. Connection to PC Serial Port

Serial Ports

Both ports are RS-232 and RS-422/RS-485 compatible. Both ports acting simultaneously can each support up to 19.2 Kbaud full duplex data communications.

Port 1 (3PL) and Port 2 (4PL)

Connectors 3PL and 4PL contain signals for both RS-232 and RS-422/RS-485 types of communication circuits. The pin-out for the RS-232 signals are per the RS-232 specification with an exception that pins not normally used for RS-232 are used for RS-422/RS-485 signals. Details are shown in tables 1 and 2.

Table 1. Port 1 or 2 RS-232 Signals

PIN	FUNCTION	SIGNAL NAME	I/O
1	Shield	-	-
2	Transmitted Data	TD	Output
3	Received Data	RD	Input
4	Request To Send	RTS	Output
5	Clear To Send	CTS	Input
7	Signal Ground	0V	-
8	Data Carrier Detect	DCD	Input
20	Data Terminal Ready	DTR	Output

Table 2. Port 1 or 2 RS-422/RS-485 Signals

PIN	FUNCTION	SIGNAL NAME	I/O
9	Send Data (A)	SD (A)	Output
10	Request to Send (A)	RTS (A)	Output
11	Clear to Send (A)	CTS (A)	Input
12	Termination for pin 13	-	-
13	Receive Data (A)	RD (A)	Input
21	Send Data (B)	SD (B)	Output
22	Request to Send (B)	RST (B)	Output
23	Clear to Send (B)	CTS (B)	Input
24	Termination for pin 23	-	-
25	Receive Data (B)	RD (B)	Input

Configuration

There are no DIP switches or jumpers on this module for configuration. Use the IC641 (MS-DOS) programming software configuration function to configure the State Logic CPU for this module. **Configure this module as catalog number IC697PCM711 with Configuration Mode set to PCM CFG.**

The SCM is installed in slots 2 through 5 of rack 0. The following table explains the correlation between the slot number and the port number used in the State Logic program.

Table 3. Slot to Port Number Correlation

SLOTNUMBER	PORTNUMBER
2	1 and 2
3	3 and 4
4	5 and 6
5	7 and 8

Status Indication

One Status LED is available as shown in Figure 2. This LED indicates the condition of the module.

Controls

One pushbutton is provided. Push and hold for less than 5 seconds to reset the module. Push and hold for more than 5 seconds and the module factory default configuration will be installed which may require the State Logic program to be reloaded.

Batteries

A lithium battery (IC697ACC701) is installed as shown in figure 2. This battery maintains serial port configuration information when power is removed. Be sure to install the new battery before removing the old battery. If during power-up diagnostics a low battery is detected the Module OK LED (top) will not stay on.

GFK-1039B
August 1997

Serial Communications Module for State Logic CPU

Table 4. References

Reference	Title
1	State Logic Control System User's Manual
2	Programmable Controller Reference Manual
3	Programmable Controller Installation Manual

Table 5. Specifications for IC697CMM712 †

Battery:	
Shelf life	10 years at 20°C (68°F)
Memory retention	6 months nominal without applied power.
Serial Ports	RS-232/RS-422/RS-485 compatible
Current Required from +5 VDC Backplane Bus	0.7 amps
VME	System designed to support the VME standard C.1

† Refer to GFK-0867B, or later for product standards and general specifications. For installations requiring compliance to more stringent requirements (for example, European Union), refer to *Installation requirements for Conformance to Standards*.

Table 6. Ordering Information

Description	Catalog Number
Serial Communications Module for State Logic, 12 Mhz, 20 Kbyte	IC697CMM712
Lithium Battery	IC697ACC701

Note: For Conformal Coat option, or Low Temperature Testing option please consult the factory for price and availability.

GFK-0370F
August 1997

Communications Coprocessor Module (CMM)

Features

- Single-Slot Module
- SNP/SNPX Protocol (master, slave)
- CCM Protocol (master, slave, peer)
- RTU Modbus Protocol (slave only)
- Supports connection to MS-DOS® or Windows® programming and configuration software package (monitor only)
- 12 Mhz, 80C186 Microprocessor
- Two RS-422/RS-485 or RS-232 Serial Ports
- CCM, RTU and SNP/SNP-X Available on Either or Both Ports
- Simultaneous Communications on Both Ports (up to 9.6 Kbps, or 19.2 Kbps individually)
- High Performance Access to PLC Memory
- Three Status LEDs
- Reset pushbutton
- Soft Switch Configuration (no switches or jumpers)
- No Battery Required

Functions

The Communications Coprocessor Module (CMM) is a member of a family of communication modules, and provides both communications control (CCM), remote terminal (RTU), and general IC69* communications (SNP) functionality. CCM, RTU and SNP are available on either or both serial ports in any of nine possible configurations: CCM/CCM, CCM/RTU, RTU/CCM, RTU/RTU, SNP/SNP, SNP/CCM, CCM/SNP, SNP/RTU, and RTU/SNP

The CMM provides both the RS-232 and RS-485 Interfaces and communicates with the PLC CPU over the backplane. Many CMMs can be placed in a single IC697 PLC system as illustrated by Figure 2.

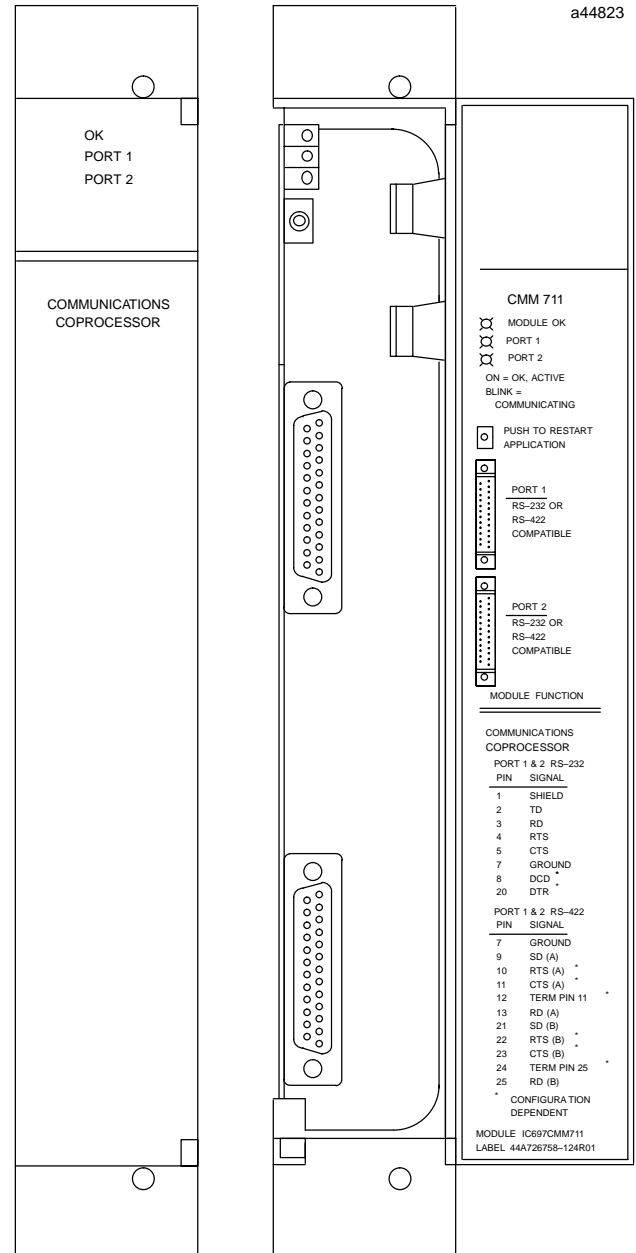

Figure 1. Communications Coprocessor Module

© MS-DOS and Windows are registered trademarks of Microsoft Corporation.

GFK-0370F
August 1997

Communications Coprocessor Module (CMM)

CCM:

Functions provided by the CMM module in the CCM mode of operation are: read/write of register, input and output tables (PLC memory types %R, %I and %Q); bit set/clear of inputs and outputs (%I and %Q); read of scratch pad; Q sequence commands for fast reads; and the ability to modify the diagnostic status word.

In the master and peer CCM configurations, the CMM module initiates communications with remote devices through application ladder program communications requests (COMREQs).

RTU:

The RTU mode of operation is a query/response protocol used for communicating between the CMM and a host computer. The host computer is the master device and transmits the query to the RTU slave which responds to the master. In RTU mode, only slave configuration is available.

In the RTU slave protocol, the following functions are provided: read input and output tables (%I and %Q), read analog input (%AI), read register table (%R), read scratchpad, read exception status, force a single or multiple output(s) (%Q), preset a single or multiple register(s) (%R), report the device type, and perform loopback maintenance.

SNP/SNP-X:

SNP is the native protocol of all IC69* PLCs. SNP is a master-slave protocol, where the slave device responds to requests from the master. An SNP slave device is built into every IC69* PLC. Each serial port on the CMM can be configured to provide SNP master or slave capability.

The SNP protocol on the CMM module provides read and write access to PLC memory (types %R, %I, %Q, %AI, %AQ, %T, %M, %P, %L, and %G), full Series 90 Datagram support, and many status and control functions. An Autodial feature is also provided to control a modem attached to an SNP master port.

The SNP-X extensions to SNP provide easy-to-use, high performance read and write access to PLC memory (types %R, %I, %Q, %AI, %AQ, %T, %M, and %G). SNP-X is especially useful for simple, high-speed data acquisition and control in multidrop configurations.

As an SNP master, the CMM module initiates communications with remote devices through application ladder programs communication requests (COMREQS). An SNP master port on a CMM module can communicate with the SNP slave port built into any IC69* PLC, or with other SNP slave devices.

As an SNP slave, the CMM module provides additional communications port(s) for connection to remote operator interface units or other SNP communications devices. The MS-DOS or Windows based software package may be connected to an SNP slave port on a CMM module for data monitoring only. Programming and configuration of IC69* PLCs are not possible through the CMM SNP ports.

Communications Coprocessor Module (CMM)

GFK-0370F
August 1997

Systems Configuration

Figure 2 illustrates typical CMM interface installations in a IC69* PLC system.

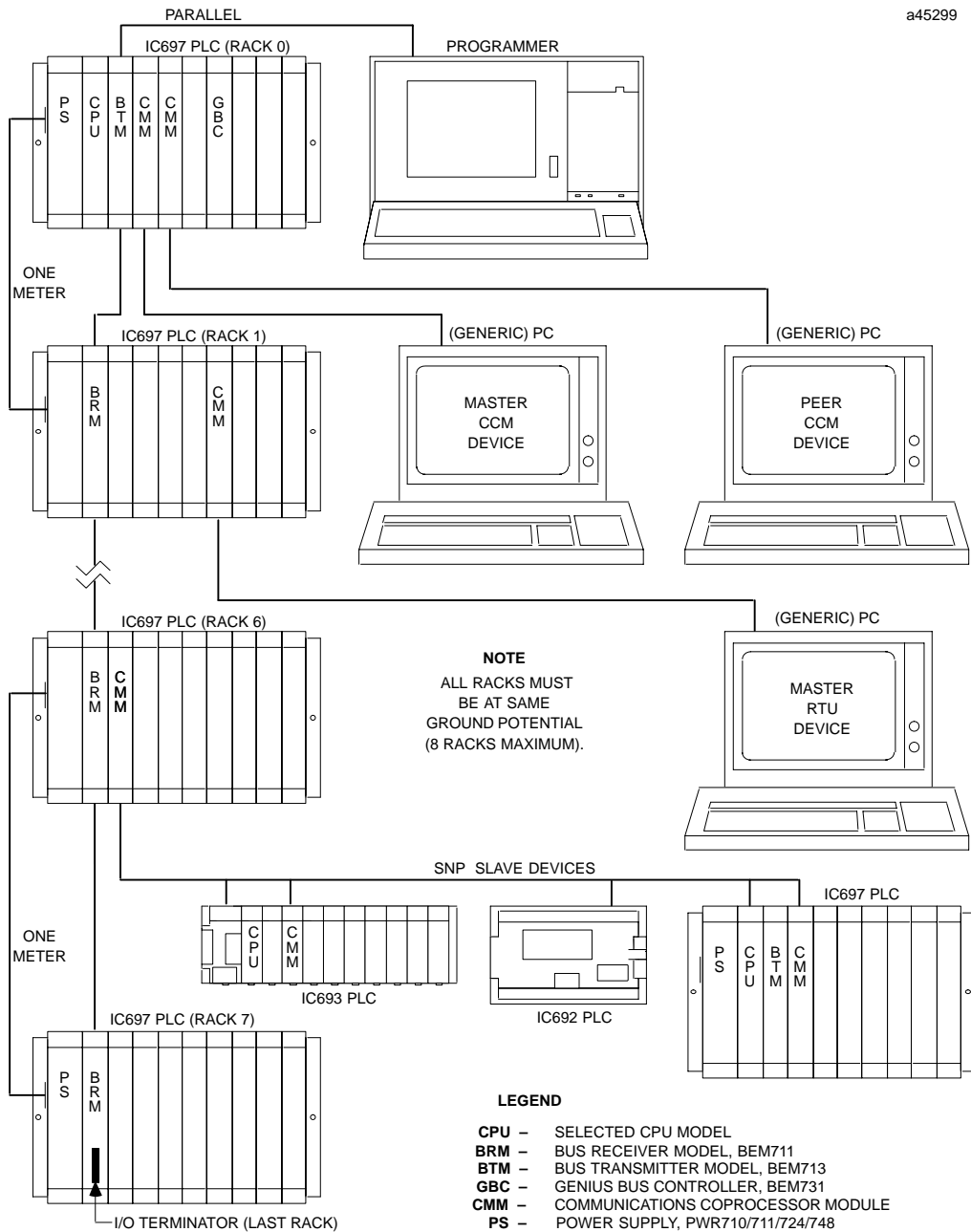

Figure 2. Typical PLC System Configuration

GFK-0370F
August 1997

Communications Coprocessor Module (CMM)

Module Physical Description

The CMM module is a single-slot module that plugs into either the IC697 PLC or I/O rack.

Figure 3 shows the maintenance controls and indicators located on the CMM module.

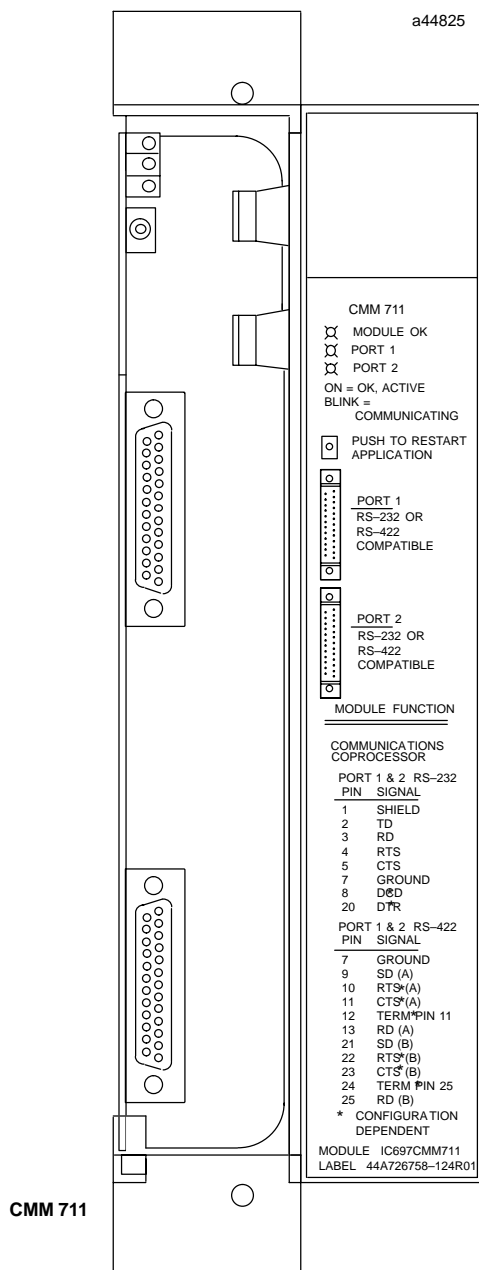

Figure 3. CMM Module - User Details

User Maintenance Items

The CMM module has the following user-accessible elements:

- Three LEDs located at the top of the module.
- Restart Pushbutton: located immediately beneath the LEDs.
- Two Serial Ports: two 25-pin female connectors provide RS-232 and RS-422/RS-485 communication.

Installation

Installation should not be attempted without referring to the Installation Manual. (See Related Publications listed on page 6.)

- Make sure rack power is OFF before attempting to install module.
- Install module in the rack (see Figure 2).
- Turn ON power.

The CMM is configurable only using the MS-DOS or Windows programming software package.

Status Indication

Three Status LEDs are available as shown in Figure 3. The top LED indicates the condition of the module. The bottom two LEDs indicate activity at the serial ports: Port 1 LED indicates activity on port 1; Port 2 LED indicates activity on port 2.

The module should power up and blink the top LED. When the diagnostics have completed successfully, the top LED stays on.

Pushbutton Control

One pushbutton is provided. Push to reinitialize communications at both serial ports.

Serial Ports

Both ports are RS-232 and RS-422/RS-485 compatible. Both ports acting simultaneously can each provide up to 9.6 Kbps of full duplex data communications, or up to 19.2 Kbps individually.

Communications Coprocessor Module (CMM)

GFK-0370F
August 1997

Port 1 (3PL) and Port 2 (4PL):

Connectors 3PL and 4PL contain signals for both RS-232 and RS-422/RS-485 types of communication circuits. The pin assignment for the RS-232 signals are per the RS-232 specification with an exception that pins not normally used for RS-232 are used for RS-422/RS-485 signals. Refer to Tables 1 and 2.

Table 1. Port 1 or 2: RS-232

Pin	Function	Signal Name	I/O
1	Shield	-	-
2	TransmittedData	TD	Output
3	ReceivedData	RD	Input
4	Request To Send	RTS	Output
5	Clear To Send	CTS	Input
7	SignalGround	0V	-
8	Data Carrier Detect	DCD	Input
20	Data TerminalReady	DTR	Output

Table 2. Port 1 or 2: RS-422/RS-485

Pin	Function	Signal Name	I/O
9	Send Data (A)	SD (A)	Output
10	Request To Send (A)	RTS (A)	Output
11	Clear To Send (A)	CTS (A)	Input
12	Termination for pin 11	-	-
13	Receive Data (A)	RD (A)	Input
21	Send Data (B)	SD (B)	Output
22	Request To Send (B)	RTS (B)	Output
23	Clear To Send (B)	CTS (B)	Input
24	Termination for pin 25	-	-
25	Receive Data (B)	RD (B)	Input

Configuration

There are no user DIP switches or jumpers on this board for configuration. However, the board must be configured before operation using the MS-DOS or Windows software package. Refer to the Related Publications listed on page 6.

GFK-0370F
August 1997

Communications Coprocessor Module (CMM)

Table 3. Related Publications

Reference	Title
1	Programming Software User's Manual
2	Programmable Controller Reference Manual
3	Programmable Controller Installation Manual
4	PLC Serial Communications User's Manual
5	Using the Windows Programmer (GFK-1295)

Table 4. Module Specifications †

Serial Ports	RS-232 and RS-422/RS-485 compatible
Current Required from +5V backplane bus	0.7 amps
VME	System designed to support the VME standard C.1

† Refer to GFK-0867B, or later for product standards and general specifications. For installations requiring compliance to more stringent requirements (for example, European Union), refer to *Installation requirements for Conformance to Standards*.

Table 5. Ordering Information

Description	Catalog Number
Communications Coprocessor Module (CMM)	IC697CMM711

Note: For Conformal Coat option, or Low Temperature Testing option please consult the factory for price and availability.

GFK-0834D
November 1999

Redundancy Communications Module

Features

- High Speed Parallel Bus Expansion Interface
- Supports Hot Standby and Enhanced Hot Standby CPU Redundancy system configurations
- Provides path for shared I/O and synchronizing message between Primary and Secondary PLCs
- Five LED indicators for board and system status
- Pushbutton switch for manual switch from active to backup unit
- Software configuration using MS-DOS® programming software configuration function

Functions

This Redundancy Communications Module (RCM) provides a path for a synchronizing message from the active to the backup unit which is used to synchronize the two CPUs in a Hot Standby or Enhanced Hot Standby CPU Redundancy system. It also provides the path for the transfer of shared I/O data between the two units. The physical connection between units in a redundancy system can have up to 25 feet (7.5 meters) total of interconnecting cable. The CPUs for Hot Standby CPU Redundancy systems can be either IC697CPU780, IC697CGR935, or IC697CGR772.

The module occupies a single slot and has two connectors, the top connector is for attachment to the upstream BTM or BRM and the bottom connector is unused. The RCM can be installed in slots 2 through 9 of rack 0 (CPU rack).

Five green LEDs provide status indication of the health of the RCM module and monitor the control status of the Hot Standby CPU Redundancy system. These LEDs are labeled *BOARD OK*, *LOCAL READY*, *LOCAL ACTIVE*, *REMOTE READY*, and *REMOTE ACTIVE*. Local refers to the system that the RCM is in; remote is the other system connected through the expansion bus and is automatically configured by the system to be in slot 1 of rack 7. Rack 7, however, is not available for physical I/O.

A pushbutton on the module allows you to manually switch control from the active to the backup unit (if the backup unit is ready) which allows maintenance of the previously active unit while the system is on-line.

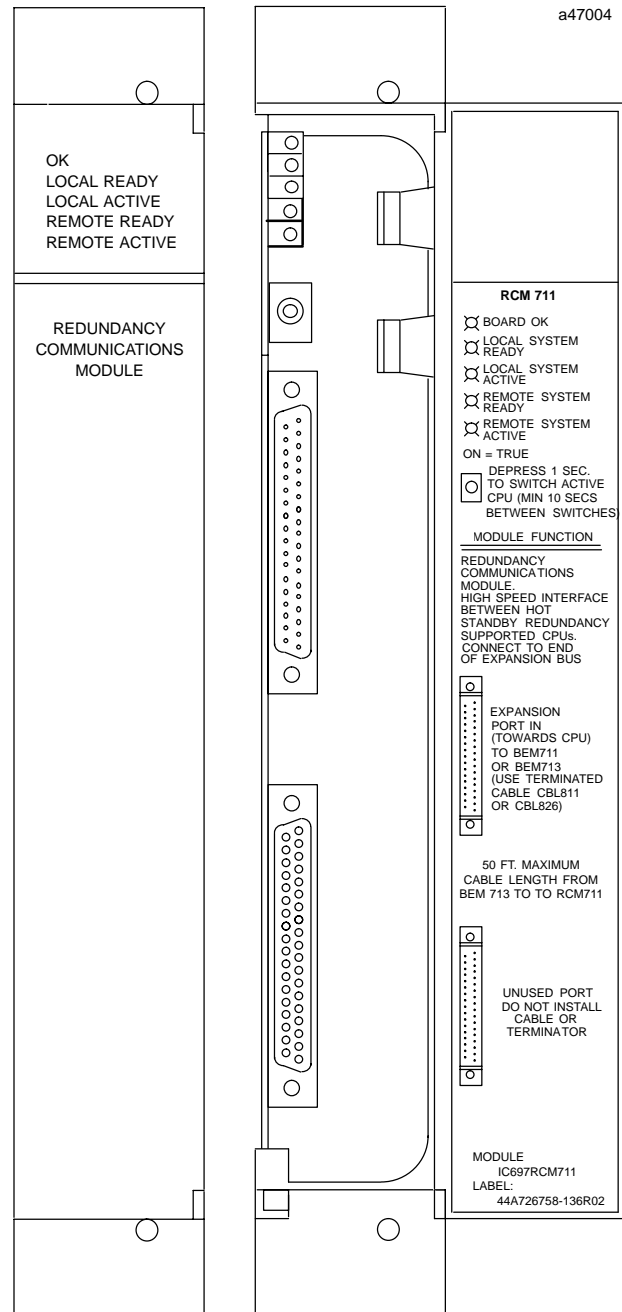

© MS-DOS is a registered trademark of Microsoft Corporation.

GFK-0834D
November 1999

Redundancy Communications Module

Installation

- Installation should not be attempted without referring to either the *Hot Standby CPU Redundancy User's Guide* or *Enhanced Hot Standby CPU Redundancy User's Guide* and the applicable *Programmable Controller Installation Manual*.
- Make sure rack power is off.
- Install in any slot of rack 0 (except slot 1).
- Connect applicable cable to module (either IC697CBL811 or IC697CBL826).
- Turn on power.

An example of a Hot Standby CPU Redundancy configuration with two CPU racks is shown in Figure 1. This configuration assumes that no local I/O requiring expansion racks is included in the system.

I/O Bus Termination

To allow for easy replacement of a faulty RCM, it should be located at the end of the expansion bus and connected using a special terminated cable - catalog numbers IC697CBL811 (10 feet (3 meters)) or IC697CBL826 (25 feet (7.5 meters)). This cable can be

removed with minimal disruption of the expansion bus, especially when one or more expansion racks are included in the system.

Expansion Rack Attachment

Using cable IC600WDXXX (where XXX is length in feet as shown in Table 3) a Bus Transmitter Module (BTM) in the CPU rack connects to a BRM in an expansion rack. Additional expansion racks are added by daisy-chaining cabling between BRMs with the RCM *always* connected last.

Removing a Module

- Grasp the board firmly at the top and bottom of the board cover with your thumbs on the front of the cover and your fingers on the plastic clips on the back of the cover.
- Squeeze the rack clips on the back of the cover with your fingers to disengage the clip from the rack rail and pull the board firmly to remove it from the backplane connector.
- Slide the board along the card guide and remove it from the rack.

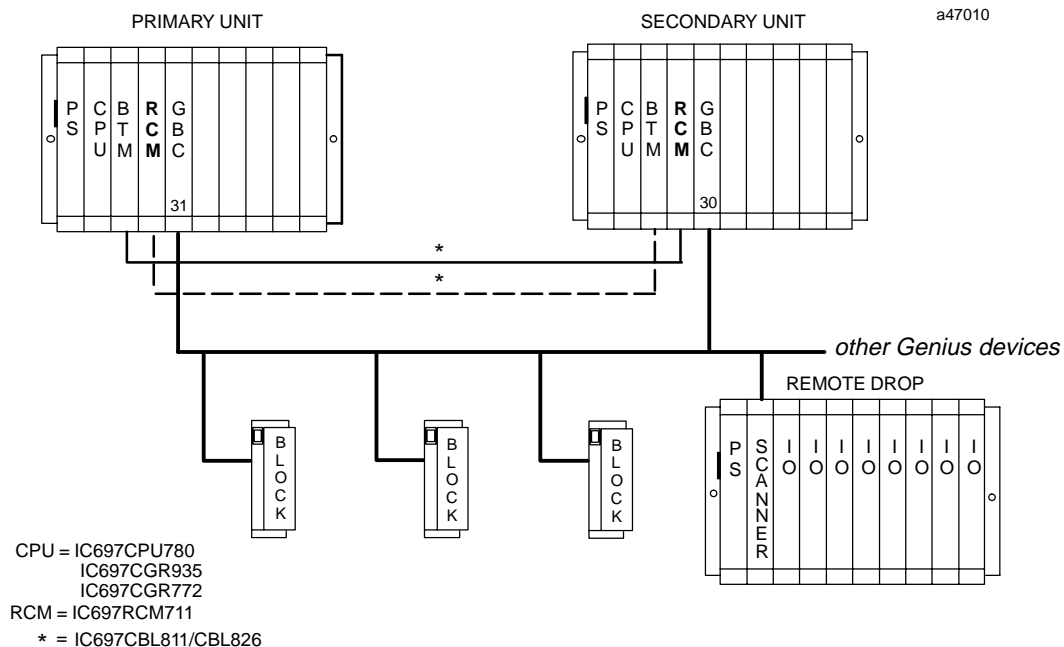

Figure 1. Location of Redundancy Communications Modules in a Hot Standby CPU Redundancy System

Redundancy Communications Module

GFK-0834D
November 1999

Status Indications

The five green LEDs at the top of the module provide status information as shown in figure 3. The top LED (BOARD OK) is ON when power is applied, the board is configured, there were no diagnostic failures in the RCM, no diagnostic failures when establishing communications (the link) with the other RCM, and no failures in communications on the link.

The other LEDs (LOCALREADY, LOCALACTIVE, REMOTE READY, and REMOTE ACTIVE) indicate the control status of the Primary and Secondary units in a Hot Standby CPU Redundancy system. For detailed descriptions of each of these LEDs, refer to the *Hot Standby CPU Redundancy User's Guide*, or the *Enhanced Hot Standby CPU Redundancy User's Guide*.

Unit Selection Pushbutton

A pushbutton on the module, which when depressed for at least 1 second then released, allows you to manually switch control from the active unit to the backup unit if both units are ready. After switching roles, another switch is not allowed by the system for at least 10 seconds.

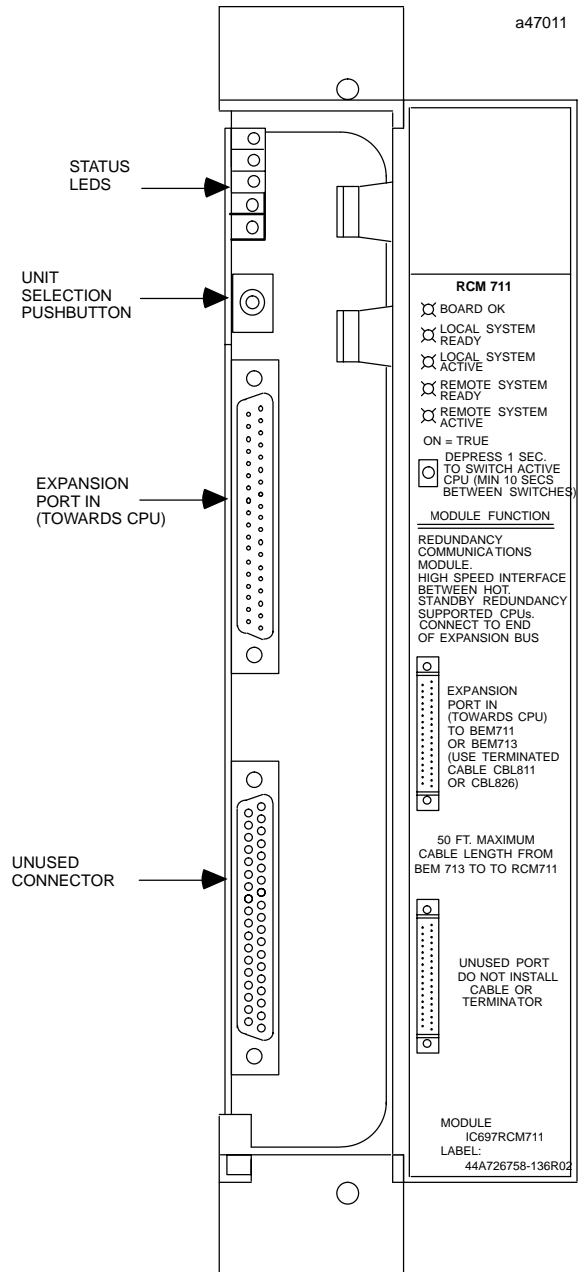

Figure 2. Redundancy Communications Module User Details

GFK-0834D
November 1999

Redundancy Communications Module

Table 1. References

Reference	Title
1	Programming Software User's Manual
2	Programmable Controller Reference Manual
3	Programmable Controller Installation Manual
4	Hot Standby CPU Redundancy User's Guide
5	Enhanced Hot Standby CPU Redundancy User's Guide

Table 2. Specifications for IC697RCM711 †

Current required from 5V Bus	1.2 amps
Expansion Interface Specification	
Maximum cable length	50 feet (15 meters)
Effective Data Rate	500 Kbytes/sec
Electrical Isolation	Non-isolated differential communication.
VME	System designed to support the VME standard C.1

† Refer to GFK-0867B, or later for product standards and general specifications. For installations requiring compliance to more stringent requirements (for example, European Union), refer to *Installation Requirements for Conformance to Standards*.

Table 3. Ordering Information

Description	Catalog Number
Redundancy Communications Module	IC697RCM711
CPU modules for Hot Standby CPU Redundancy	IC697CPU780 IC697CGR772 IC697CGR935
Bus Transmitter Module	IC697BEM713
Terminator Plug	IC697ACC702
I/O Cable: 5 feet (1.5m), 10 feet (3m), 25 feet (7.5m), 50 feet (15m)	IC600WD005/010/025/050
I/O Cable with Built-In Termination - 10 feet (3 meters)	IC697CBL811
I/O Cable with Built-In Termination - 25 feet (7.5 meters)	IC697CBL826

Note: For Conformal Coat option, or Low Temperature Testing option please consult the factory for price and availability.

Programmer Interface Modules

IC640WMI910/310

GFK-0166F
July 1995

Work Station Interface (XT, AT)

- Features
- High Performance Programmer Interface
- Parallel and Serial Interface to IC69* PLCs
- Resides in IC640 computer (or IBM PC, XT, AT)
- Uses PLC address space normally used by COM2
 - * IC697 or IC693 PLC

Functions

The Work Station Interface provides a parallel or serial interface to the IC69* family of PLCs. It is installed

in an IC640 computer or an IBM® -compatible XT or AT. It requires one full AT or XT slot.

Installation

- Installation should not be attempted without referring to the applicable *Programmable Controller Installation Manual*.
- Make sure programmer power is off.
- Install in an IC640 computer as shown in figures 1 and 2.
- Turn on power.

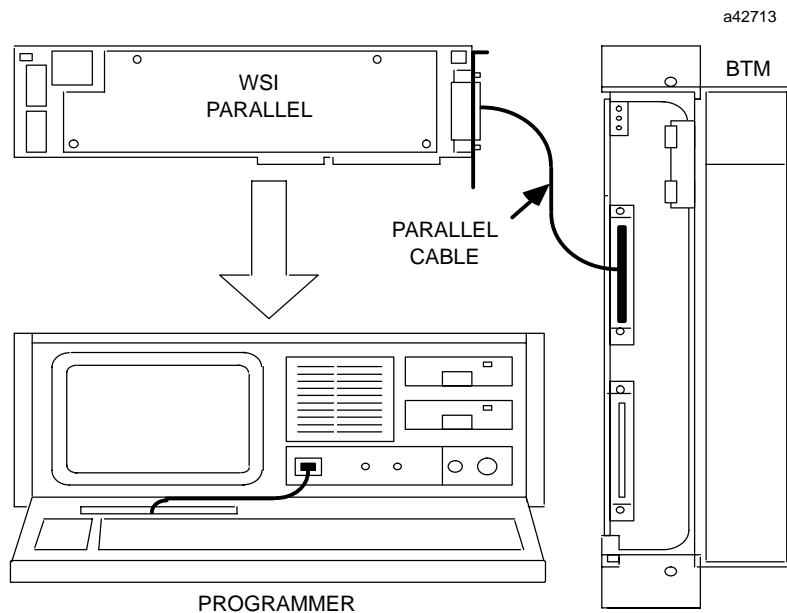

Figure 1. Interconnection of IC640 Computer, Parallel Work Station Interface and Bus Transmitter Module

® IBM is a registered trademark of International Business Machines Corporation.

GFK-0166F
July 1995

Work Station Interface (XT, AT)

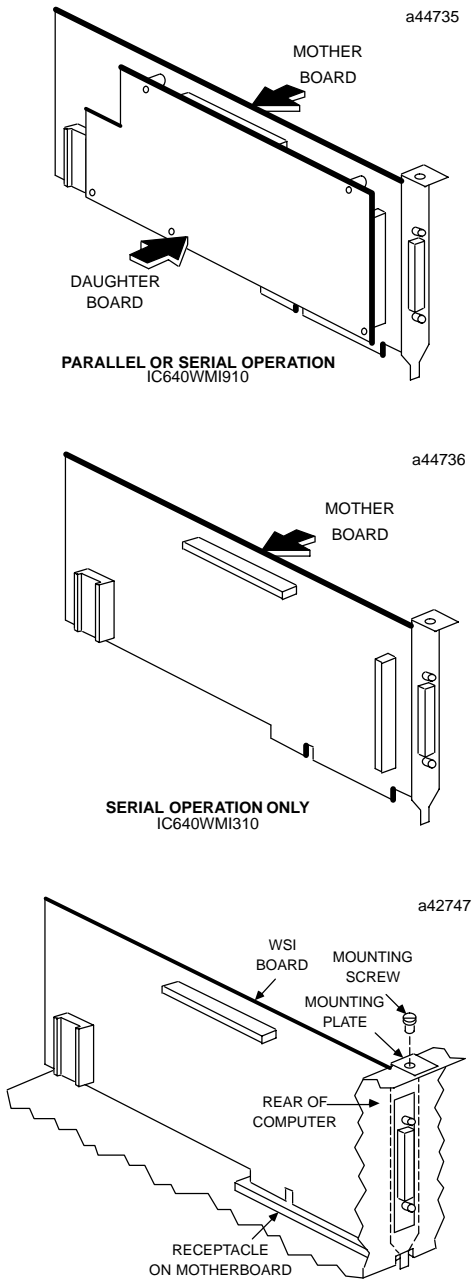

Figure 2. WSI Installation in IC640 Computer

Cable Description

The parallel attachment (IC697 PLC only) is to the top connector on the Bus Transmitter Module through cable IC600WD005 or equivalent as shown in figures 1 and 3.

Warning

The IC697 PLC rack and programmer ground connections must be at the same ground potential. Incorrect wiring will result in damage to the WSI.

The serial attachment is to the serial port connector on the IC697 PLC CPU or to the serial port on the IC693 power supply.

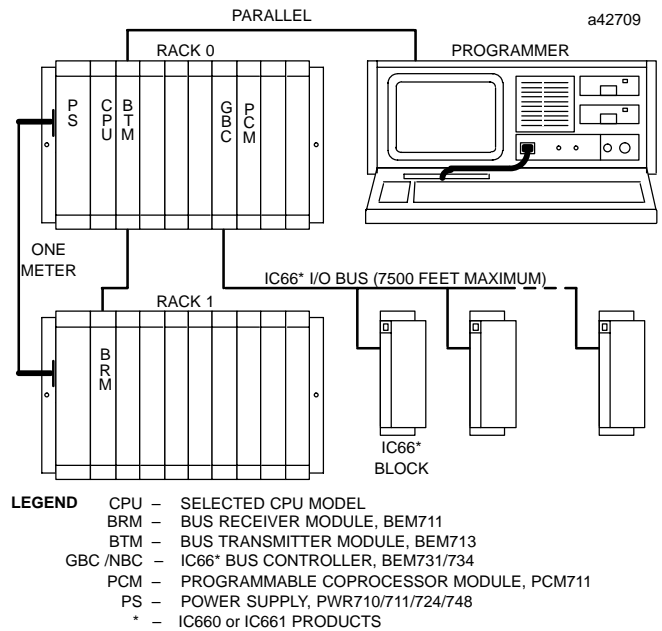

Figure 3. Typical IC697 PLC System Configuration

Table 1. References

Reference	Title
1	ProgrammingSoftware User's Manual
2	Programmable Controller Reference Manual
3	Programmable Coprocessor Module and Support Software User's Manual
4	MegaBasic Programming Language Reference Manual
5	Programmable Controller Installation Manual

Table 2. Specifications for IC640WMI910/IC640WMI310 †

Parallel Interface Specification	
Effective Data Rate	500 Kbytes/second (parallel)
Time to store 8k word program	1 - 2 seconds
Maximum cable length	50 feet (15 meters)
Serial Interface Specification	
Maximum Data Rate	19.2 Kbytes/second
RS485 Maximum Cable Length	4000 feet (1200 meters)
VME	System designed to support the VME standard C.1

† Refer to GFK-0867B, or later for product standards and general specifications.

Table 3. Ordering Information

Description	Catalog Number
Work Station Interface, Parallel	IC640WMI910
Cable, Parallel, 5 feet (1.5 meters)	IC600WD005A (5 ft. cable)
Work Station Interface Board, Serial Only (IC693)	IC640WMI310
Cable, Serial (XT)	IC690CBL701, 10 feet (3 meters)
Cable, Serial (AT)	IC697CBL702, 10 feet (3 meters)

Interface Modules

ICIC640WMI920/320

GFK-0281D
July 1995

Work Station Interface (PC/2)

Features

- High performance programmer interface
- Combination parallel and serial interface to IC69* family of PLCs
- Resides in an IC647 computer or an IBM® Personal System/2®(PS/2®) computer
- Standard Micro-Channel® bus interface
- Configured to use PS/2 COM2 assignments
- Includes option diskette for use with standard PS/2 computers

Functions

This Work Station Interface provides a parallel or serial interface from the IC647 or PS/2 computer to the IC69* family of PLCs.

Location in System

This Work Station Interface when used as a parallel interface is connected to the Bus Transmitter Module in an IC697 PLC system as shown in figure 1.

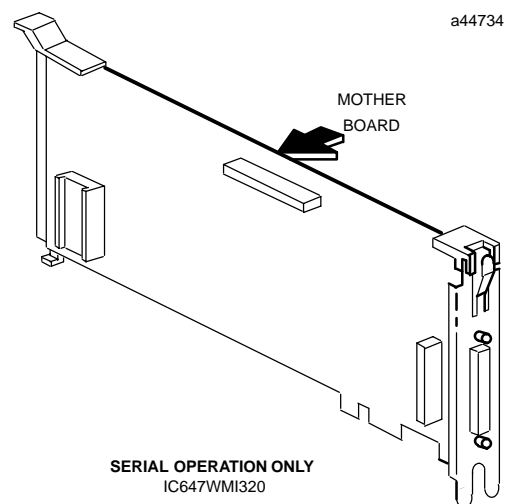
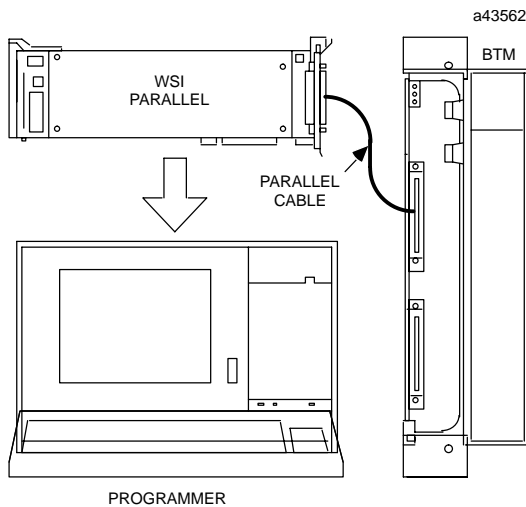
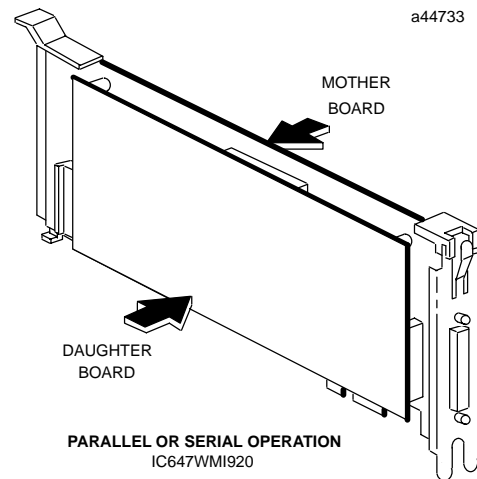

Figure 1. IC647 Computer, Parallel Work Station Interface and Bus Transmitter Module

® IBM, Personal System/2, PS/2 and Micro-Channel are registered trademarks of International Business Machines Corporation.

GFK-0281D
July 1995

Work Station Interface (PC/2)

When used as a serial interface to an IC697 PLC system or to an IC693 PLC system, the Work Station Interface is connected as shown in figures 2 and 3.

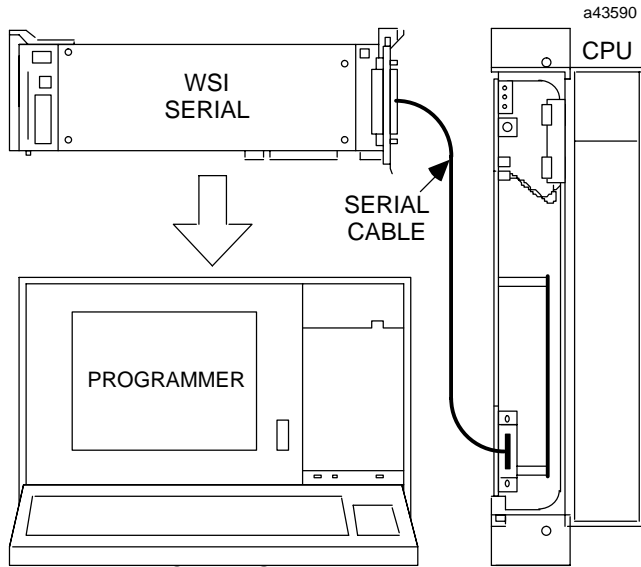

Figure 2. IC647 Computer, Serial Work Station Interface and IC697 PLC

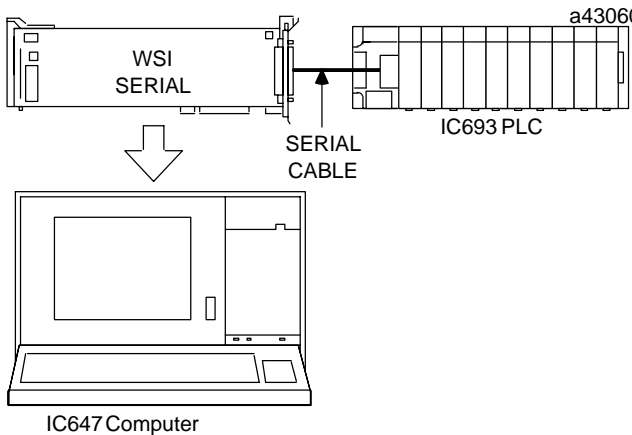
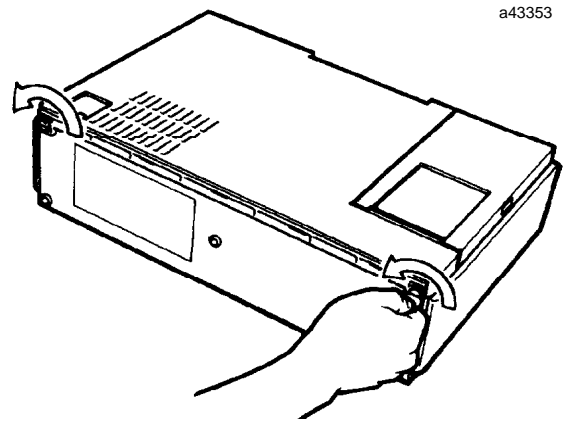

Figure 3. IC647 Computer, Serial Work Station Interface and IC693 PLC

Installation - IC647 Computer

1. Turn power OFF (Power OFF IC647 computer and attached devices).
2. Unplug all computer power cords from the electrical outlets. Make a note of all cables connected to the rear of the system unit before disconnecting them.
3. Lay the system unit on its keyboard side.
4. Loosen the bottom rear cover screws with a coin or flat blade screwdriver.



5. Open the connector housing door 1 by moving the side of the door in the direction indicated by 2.

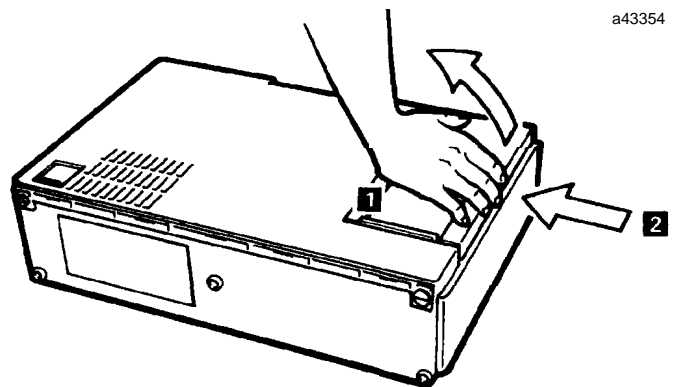

Work Station Interface (PC/2)

GFK-0281D
July 1995

6. Loosen the rear cover screw with a coin.

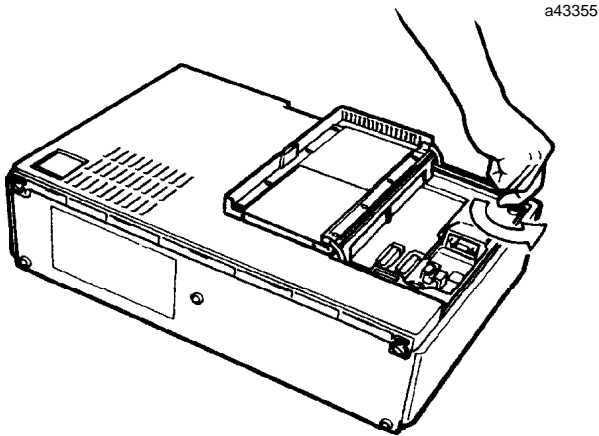

7. Move the handle to the carry position. Hold the rear cover as shown in the next figure, and lift the cover while firmly pushing the bottom at position 3 to release the first latch. Then lift the cover while strongly pushing the bottom at positions 4, 5, 6, 7 to release the other latches.

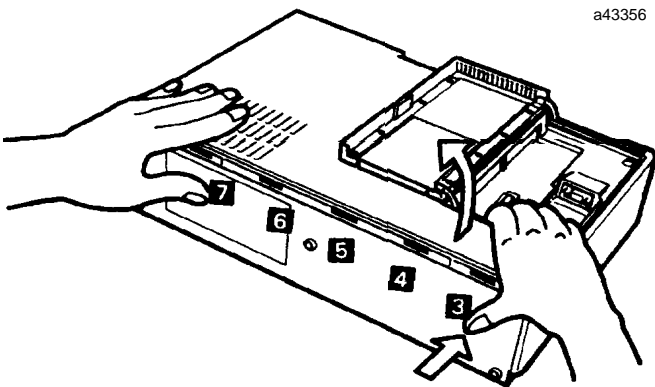

8. Before installing the Work Station Interface board into the upper expansion slot, you must remove the expansion slot cover. To do this, 1 loosen the thumbscrew (a coin may be used). Slide the expansion slot cover 2 outward, and push it to the left. You may discard the expansion slot cover.

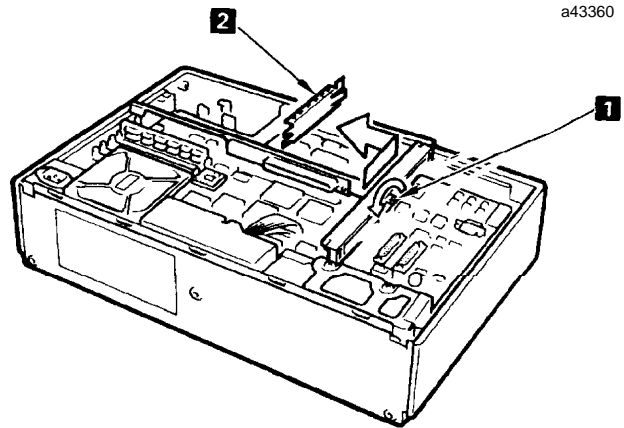

9. Align the Work Station Interface board 1 with the upper slot as shown in the next figure. Position the adapter support bracket into the holding bracket 3 before pressing the Work Station Interface into the expansion slot connector. 2 Secure the Work Station Interface in place by using the thumbscrew.

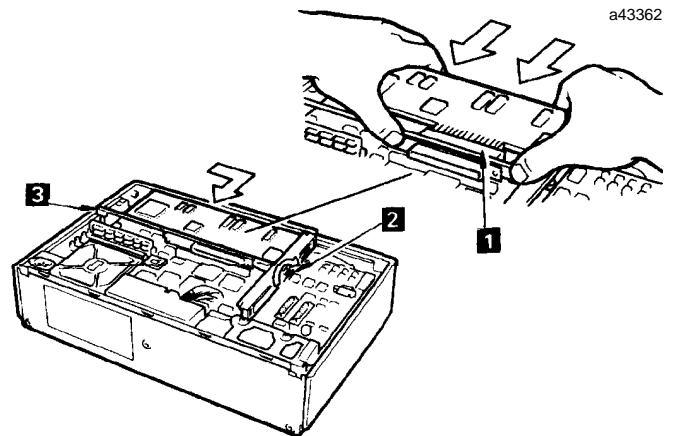

GFK-0281D
July 1995

Work Station Interface (PC/2)

10. Replace the cover by putting its left side on the system unit and pushing its right side down until it clicks in place.

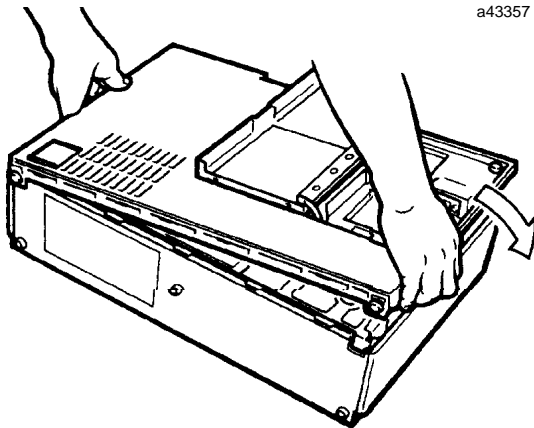

11. Lock the rear cover onto the system unit by turning the rear cover screw with a coin. *Do not over-tighten the screw.*

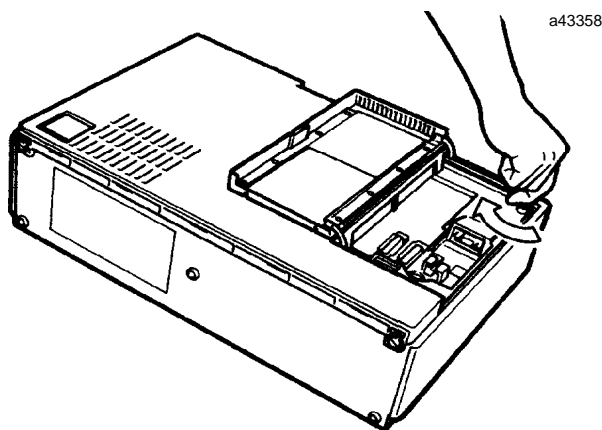

12. Tighten the bottom rear cover screws with a coin. **Again, do not overtighten the screws.**

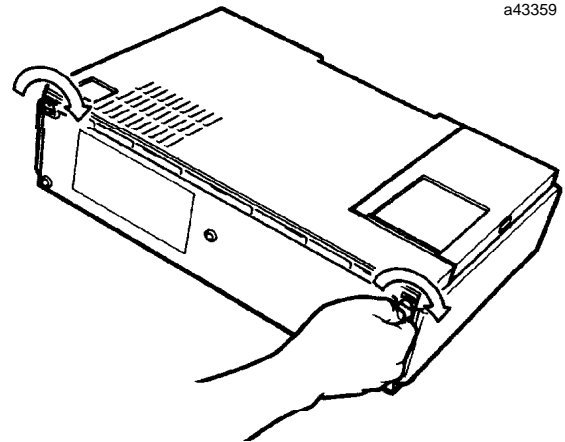

13. After installing the Work Station Interface, you must run the option diskette provided with the IC647 computer. Detailed information on using the option diskette can be found in Chapter 2 of the *PLC Programming Unit Guide to Operation*.

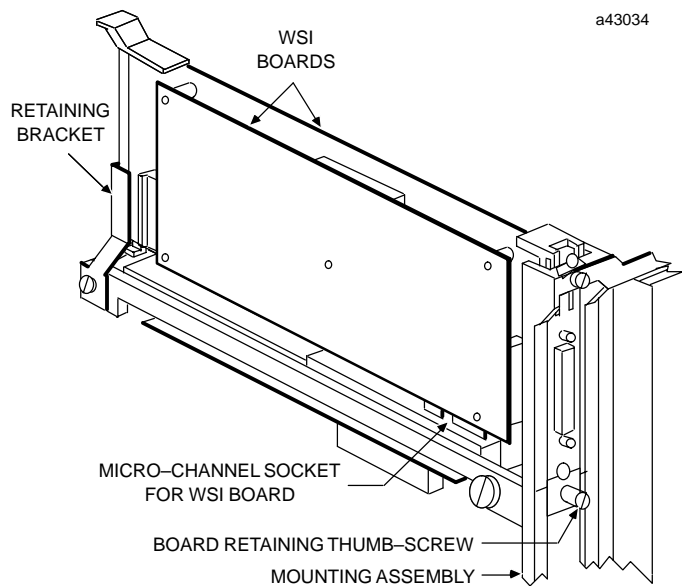

Figure 4. Detail of Work Station Interface Installation in IC647 Computer

Work Station Interface (PC/2)

GFK-0281D
July 1995

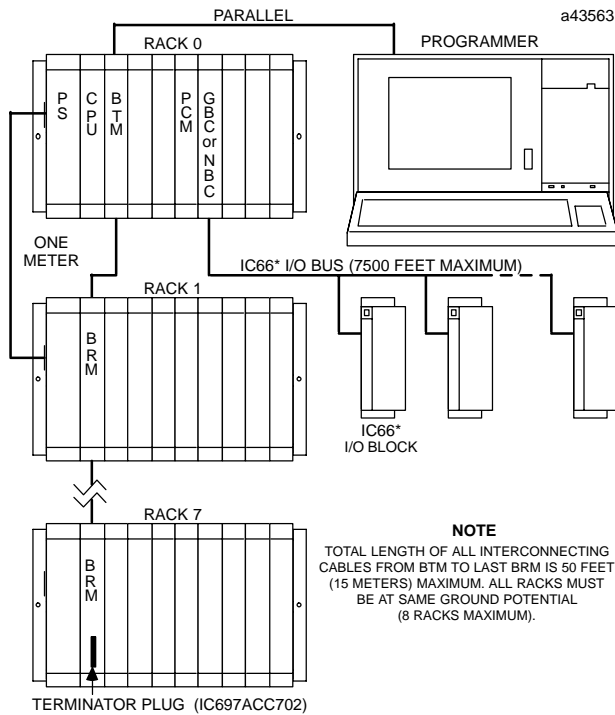

Figure 5. Typical IC697 PLC System Configuration (Parallel Interface)

Installation - Personal System/2 Computer

1. The Work Station Interface requires one full Micro-Channel slot.
2. The Work Station Interface requires one full Micro-Channel slot.
3. After installing the Work Station Interface in your PS/2, you must run the option diskette as described in the reference guide for your computer.

Cable Description

The **parallel** connection to the IC697 PLC is to the top connector on the Bus Transmitter Module through an available 10 foot (3 meters) cable, IC647CBL703 - or equivalent, as shown in figure 5.

The **serial** connection to the IC697 PLC (see figure 6) is to the serial port connector, located at the bottom of

the CPU module behind the hinged door, through an available 10 foot (3 meters) serial interface cable - IC647CBL704, or equivalent

Warning

The IC697 PLC and IC693 PLC rack and programmer ground connections must be at the same ground potential. Incorrect wiring will result in damage to the Work Station Interface module.

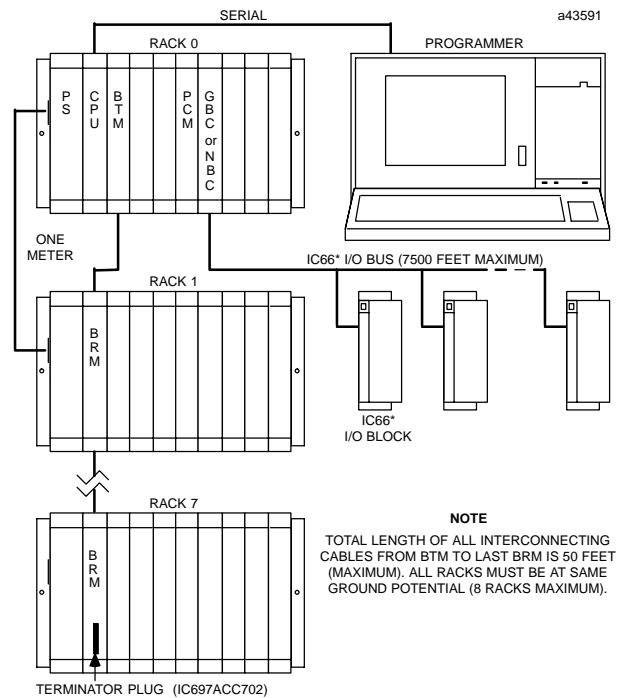

Figure 6. Typical IC697 PLC System Configuration (Serial Interface)

Serial connection to the IC693 PLC is to the serial port connector located behind the hinged door on the right front of the power supply, also through a 10 foot (3 meters) serial interface cable, IC647CBL704 - or equivalent, as shown in figure 7.

GFK-0281D
July 1995

Work Station Interface (PC/2)

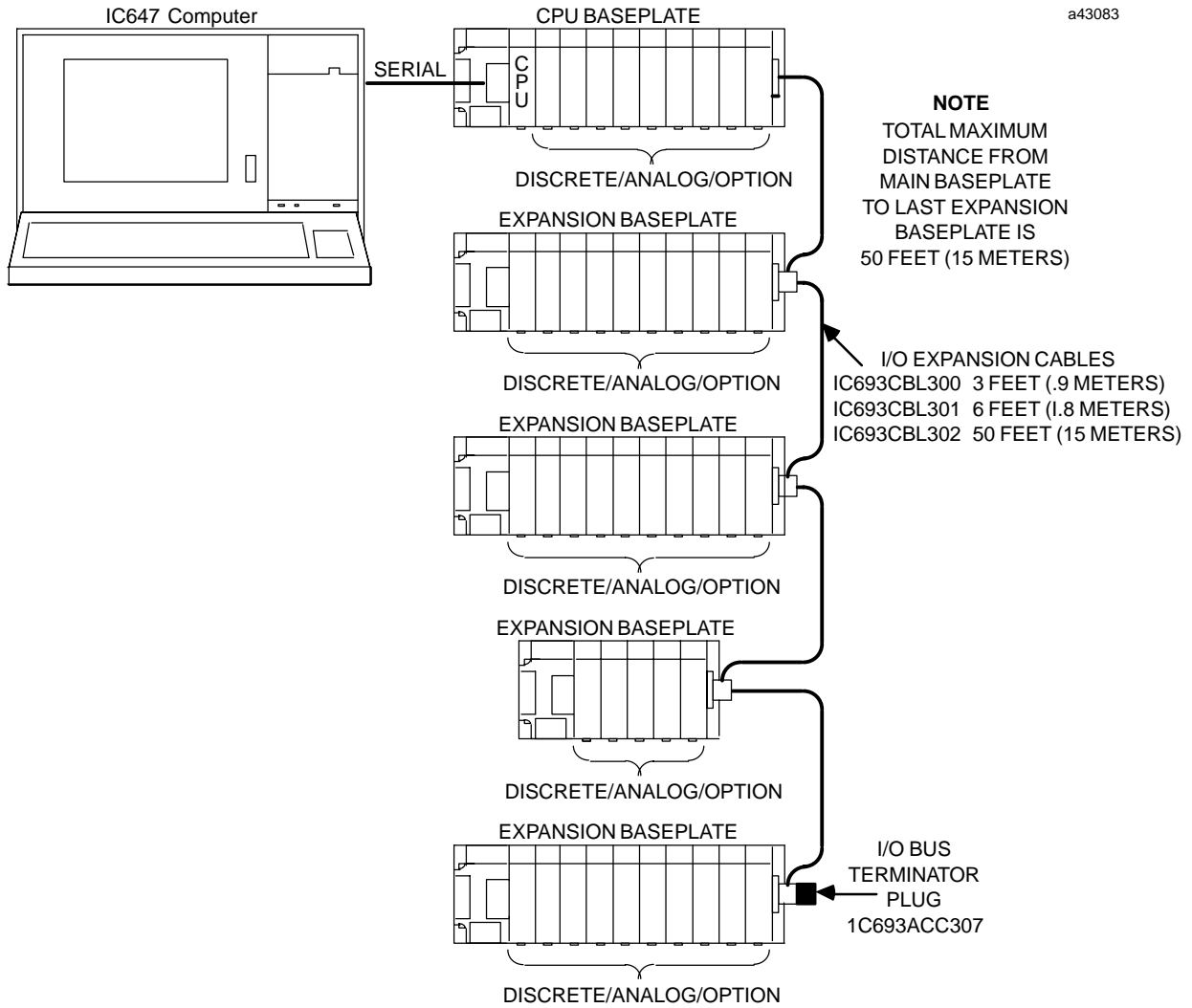

Figure 7. Typical IC693 PLC System Configuration (Serial Interface)

Table 1. References

Reference	Title
1	PLC Programming Unit Guide to Operation
2	Programming Software User's Manual (for IC697 PLC)
3	Programmable Controller Reference Manual (for IC697 PLC)
4	Programming Software User's Manual (for IC693 PLC)
5	Programming Software Reference Manual (for IC693 PLC)
6	Programmable Coprocessor Module and Support Software User's Manual
7	PCM Development Software (PCOP) User's Manual
8	Programmable Controller Installation Manual (for IC697 PLC)
9	Programmable Controller Installation Manual (for IC693 PLC)

Work Station Interface (PC/2)

GFK-0281D

July 1995

Table 2. Specifications for IC647WMI920/320 †

ParallelInterfaceSpecification	
EffectiveDataRate	50Kbytes/second
Maximumcablelength	50 feet (15 meters)
SerialInterfaceSpecification	
MaximumDataRate	19.2KBytes/second
RS485Maximumcablelength	4000 feet (1200)
VME	System designed to support the VME standard C.1

† Refer to GFK-0867B, or later for product standards and general specifications.

Table 3. Ordering Information

Description	Catalog Number
Work Station Interface Board, Parallel/Serial	IC647WMI920
Work Station Interface Board, Serial (IC693 PLC only)	IC647WMI320
ParallelInterfaceCableAssembly, 10 feet (3 meters)	IC647CBL703
SerialInterfaceCableAssembly, 10 feet (3 meters)	IC647CBL704

Features

- Convenient factory-assembled cables
- Available in lengths from 2 to 500 feet (0.6 to 150 meters) for IC600 Programmable Controllers
- Available in lengths from 5 to 50 feet (1.5 to 15 meters) for IC697 Programmable Controllers
- Selection of lengths provide flexibility in IC600 PLC and IC697 PLC installations
- Color-coded twisted pairs simplify troubleshooting

Functions

The I/O (Input/Output) cable, consisting of 16 twisted-pair wires and two connectors provides electrical continuity for the parallel I/O bus in either an IC600 or an IC697 Programmable Logic Controller (PLC) system. The same cable can be used in either

system. The cable is shielded and the individual twisted-pair wires are color-coded as shown in Table 1.

The cable is available in lengths ranging from 2 feet (0.6 meters) to 500 feet (150 meters); however, only the 5, 10, 25, and 50 foot (1.5, 3.0, 7.5, and 15 meter) lengths can be used in an IC697 PLC system.

In an **IC600** PLC system, the I/O cable extends the parallel I/O bus from rack to rack within a Local Central Processor Unit (CPU) station or Remote I/O station. It can also connect a Local I/O station to another Local I/O station or to a CPU station, or it can connect racks within a Remote I/O station.

In an **IC697** PLC system, the I/O cable extends the parallel I/O bus from rack to rack in a system requiring expansion racks.

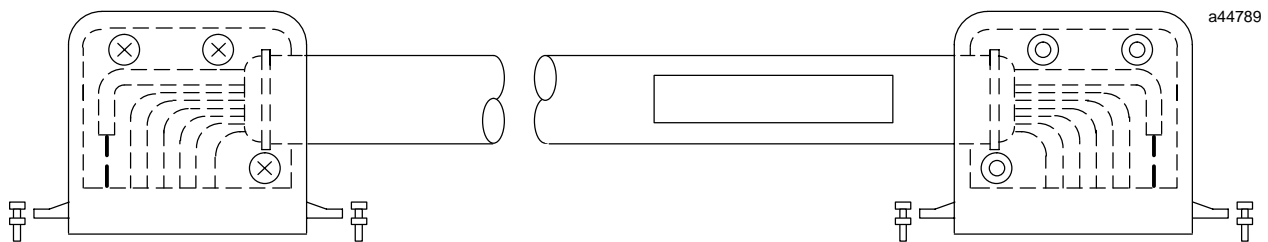

Figure 1. I/O Cable for IC600 and IC697 PLCs

GEK-83517E
November 1993

Cables - I/O

Installation

Installation should not be attempted without referring to the applicable installation manual for your PLC, either the IC697 *Programmable Controller Installation Manual*, IC600 *Installation and Maintenance User's Manual*, or IC600+ *User's Manual*.

IC600 PLC Installation

Note that the cable has one male connector and one female connector. As a general rule, the male connector on the cable connects to the upstream module and the female connector to the downstream module. Upstream is defined as being toward the CPU, downstream is away from the CPU.

The specific IC600 modules which use this cable are: I/O Control, Auxiliary I/O Control, I/O Receiver, Advanced I/O Receiver, I/O Transmitter, and the downstream (bottom connector) port of a Remote I/O Receiver module. After being attached to their respective mating connectors all connectors should be secured using the furnished screws.

The following constraints should be observed when using this cable to interconnect the modules in an IC600 or IC600+ I/O system.

1. The total cable length connecting the racks within an I/O station should be no more than 50 feet (15 meters) without I/O transmitters.
2. The cable length between a Local I/O station and the CPU station, or another Local I/O station should be no more than 500 feet (150 meters) with I/O transmitters.
3. The parallel I/O bus between any Local I/O station and the CPU rack should interface through no more than four I/O Transmitter modules (up to four I/O transmitters between the CPU and the most distant I/O rack).

IC697 PLC Installation

The male connector on the cable connects to the female (bottom) connector on the Bus Transmitter Module (BTM) and the female connector on the opposite end of the cable connects to the male (top) connector on the Bus Receiver Module (BRM) in the first expansion rack. Each additional expansion rack is connected by attaching an I/O cable from the top connector on the Bus Receiver Module in the expansion rack to the bottom connector in an (upstream) rack. The bottom

connector on the Bus Receiver Module is connected through an I/O cable to the top connector on the Bus Receiver Module in the next downstream expansion rack. This process is continued until the desired number of expansion racks are installed in the system (maximum of 7 expansion racks).

The following constraints should be observed when using this cable to interconnect the modules in an IC697 I/O expansion system.

1. The total length of all interconnecting I/O cables from the Bus Transmitter Module to the last Bus Receiver Module can be no more than 50 feet (15 meters) maximum.
2. For proper operation all racks must be at the same ground potential (8 racks maximum, CPU rack plus seven expansion racks).

Twisted-Pair Color Codes

The following table lists the pin configuration, with wire color codes, for the I/O cable.

Table 1. I/O Cable Twisted-Pair Color Codes

Pin	Wire Color	Pin	Wire Color
1	no connection	20	gray-red
2	blue-white	21	red-gray
3	white-blue	22	blue-black
4	orange-white	23	black-blue
5	white-orange	24	orange-black
6	green-white	25	black-orange
7	white-green	26	green-black
8	brown-white	27	black-green
9	white-brown	28	brown-black
10	gray-white	29	black-brown
11	white-gray	30	gray-black
12	blue-red	31	black-gray
13	red-blue	32	blue-yellow
14	orange-red	33	yellow-blue
15	red-orange	34	no connection
16	green-red	35	no connection
17	red-green	36	no connection
18	brown-red	37	shield
19	red-brown		

Note

Pin connections are the same at both ends of the connector.

Cables - I/O

GEK-83517E
November 1993

Ordering Information

Description	Catalog Number
I/O Cable, 2 feet (0.6 meters)	IC600WD002A
I/O Cable, 5 feet (1.5 meters)	IC600WD005A †
I/O Cable, 10 feet (3.0 meters)	IC600WD010A †
I/O Cable, 25 feet (7.5 meters)	IC600WD025A †
I/O Cable, 50 feet (15 meters)	IC600WD050A †
I/O Cable, 100 feet (30 meters)	IC600WD100A
I/O Cable, 200 feet (60 meters)	IC600WD200A
I/O Cable, 300 feet (90 meters)	IC600WD300A
I/O Cable, 500 feet (150 meters)	IC600WD500A

† These cables may be used in both IC600 and IC697 PLC installations; all others are for use in an IC600 system only.

Catalog Number Revision Suffix

The equipment listed above having the catalog numbers shown and the same equipment having a higher alpha suffix is designed for listing by UL for use as auxiliary control devices. The equipment is a direct replacement for equipment having the same catalog number but a lower, or no, alpha suffix.



This symbol on the nameplate means the product is listed by Underwriters Laboratories Inc. (UL Standard No 508, Industrial Control Equipment, part XVII Programmable Controller).

GFK-0153G
January 1997

Cable - Power Supply Extension

Features

- Allowstwo racks to operate from a single power supply (this feature available with 55 and 100 watt AC/DC power supplies and the 90 watt 24 and 48 VDC power supplies).
- Cable includes both +5 volt power and control signals.
- Uses a 9 pin D-type connector.
- The cable kit includes cover plate for unused power supply slot in second rack.

A single power supply can provide power for two racks under the following conditions:

1. Only +5 volt power is required in the second rack, and the total power required by both racks is within the capability of the supply.
2. The current drawn by the second rack is less than 5.2 amperes.
3. Any IC697 module can be used in second rack slots 2 through 9 except those that require +12 volts.
4. The two racks must be mounted in close proximity, as limited by the 3-foot (1 meter) length of the cable.

Functions

The Power Supply Extension Cable allows operation of two IC697CHS racks from a single power supply. The cable carries the ACFAIL and SYSRESET signals, as well as the +5 volt power bus to the second rack.

Note

This cable carries power and power sequencing signals only. Inter-rack communication and bus interface modules must be provided separately.

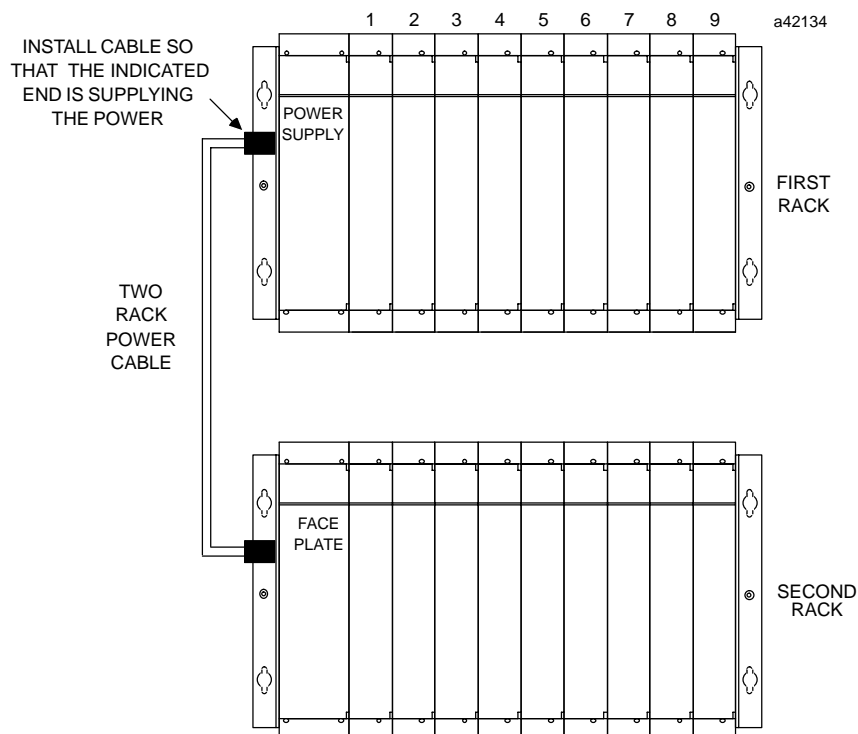

GFK-0153G
January 1997

Cable - Power Supply Extension

Operation of the Power Supply

The 55 and 100 Watt AC/DC Power Supply Modules can operate from either 120 VAC or 240 VAC nominal inputs or from a nominal 125 VDC source. The AC input voltage range can be from 90 to 264 volts AC, 50 to 60 Hz; the 125 VDC input can be from +100 to +150 VDC. The 90 Watt 24 VDC Power Supply Module can operate from a DC input of +21 to +32 VDC. The 90 Watt 48 VDC Power Supply Module can operate from a DC input of +35 to +60 VDC. Both overvoltage and overcurrent protection (as described below) apply to both the base rack and the auxiliary rack.

Overvoltage Protection

An electronic shutdown circuit protects against voltages exceeding 6.2 volts. A back-up voltage clamp is provided to protect against sustained overvoltage conditions due to either external influences or internal faults. Overvoltage due to internal faults may cause the fuse to open. For short term overvoltage conditions, normal operation will resume when the cause is removed.

Overcurrent Protection

An electronic current limit is provided on each of the DC outputs. An overload on any output will cause the voltage to collapse and may cause the other output voltages to collapse.

Normal operation will resume after removal of the overload. Some component cooling time may be required before normal operation resumes.

Power Supply Cover Plate

A cover plate is included with the cable kit for the power supply slot in the second rack. It mounts to the rack using four M2.5 screws (included).

Cable Connection

The power supply cable terminates in two 9-pin D-type connectors. The mating connector on each rack backplane is accessed through an opening in the left side panel of the rack. Approximately 6 inches (152.4mm) of clearance on the left side of the rack must be allowed for access to the connector.

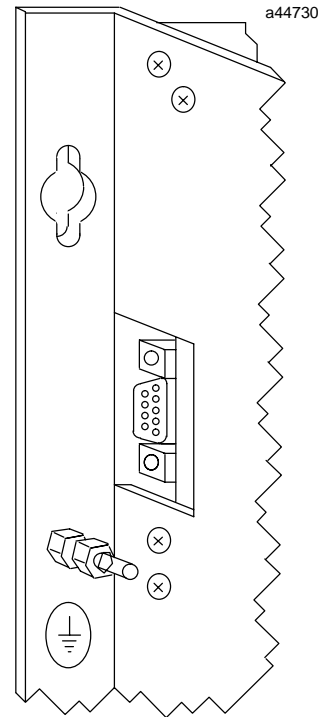

Warning

Always turn power off before connecting or disconnecting the cable. Connecting or disconnecting the cable with power applied may cause unsafe operation.

Table 1. Ordering Information

Description	Catalog Number
Power Supply Extension Cable	IC697CBL700/713

GFK-0359F
July 1995

Cables - PCM to Programmer

Features

- Cable* - Catalog number IC690CBL701 provides required signal connections between a Programmable Coprocessor Module (PCM) and an IC640 industrial computer or an IBM® PC-XT Personal Computer (PC).
- Cable* - Catalog number IC690CBL702 provides required signal connections between a PCM and an IBM PC-AT PC.
- Cable* - Catalog number IC690CBL705 provides required signal connections between a PCM and an IC647 computer or an IBM PS/2® PC.
- Prewired cables allow easy connection between the module and the programmer.

* The above cables can also be used with the IC697ADC701 and IC697GDC701 modules.

Functions

These cables provide the required signal connections between the RS-232 serial port on a PCM and a serial port on the programmer. The programmer can be an IC647 computer or PS/2 PC, an IC640 computer, or PC-XT PC (or compatible), or a PC-AT PC (or compatible).

Installation

- Installation should not be attempted without referring to the Programmable Controller Installation Manual and the manual for the module to be connected to the programmer.
- Have the proper cable for your programmer.
- Connect the cable's 25-pin male connector to the top serial port female connector on the front of the PCM module.
- Connect the cable's 9-pin female connector to the male RS-232 connector (serial port) on the selected programming device.

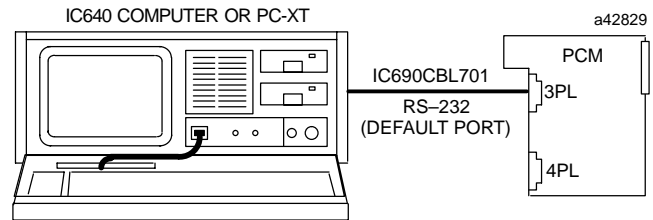

Figure 1. PCM to IC640 Computer or PC-XT Personal Computer

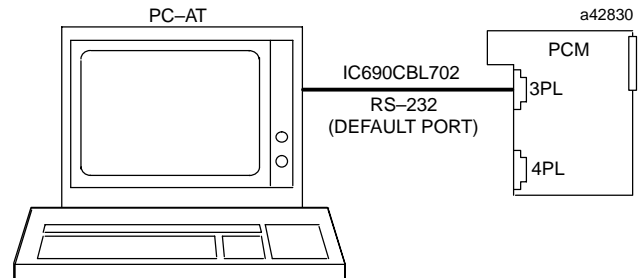

Figure 2. PCM to PC-AT Personal Computer

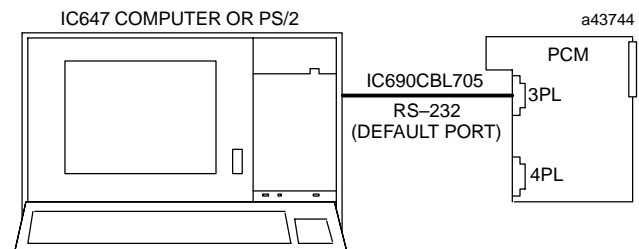

Figure 3. PCM to IC647 or PS/2 Computer

®IBM and PS/2 are registered trademarks of International Business Machines Corporation.

GFK-0359F
July 1995

Cables - PCM to Programmer

Cable Description

Each of the cables physically appear the same, the difference being the internal pin connections. Cables are 10 feet (3 meters) in length. Specifications for the cables are provided in Table 2. Wiring information is provided in Figures 4, 5, and 6.

Caution

The IC697 PLC rack or IC693 PLC baseplate that contains the PCM, and the programmer ground connections must be at the same ground potential. Incorrect wiring will result in damage to the programmer or the PCM.

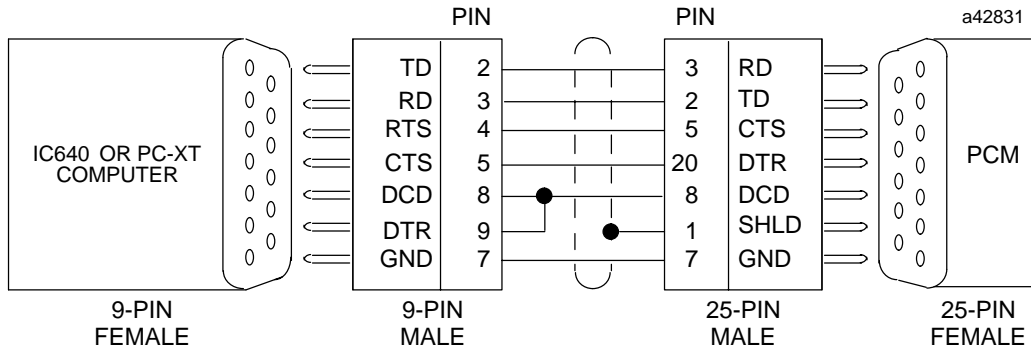

Figure 4. Wiring for PCM to IC640 or PC-XT Cable (IC690CBL701)

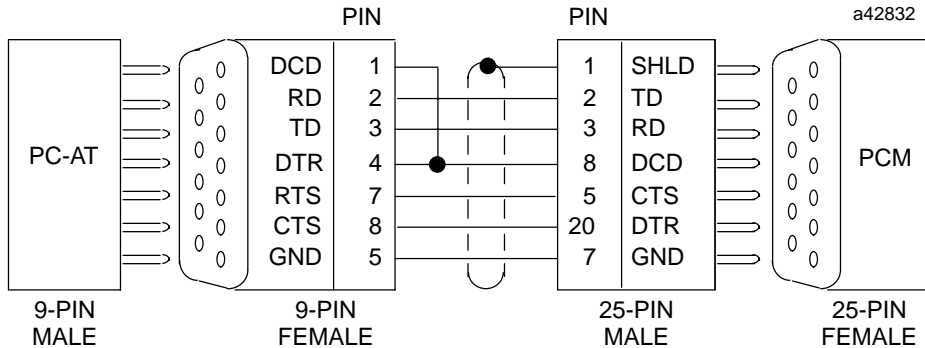

Figure 5. Wiring for PCM to PC-AT Cable (IC690CBL702)

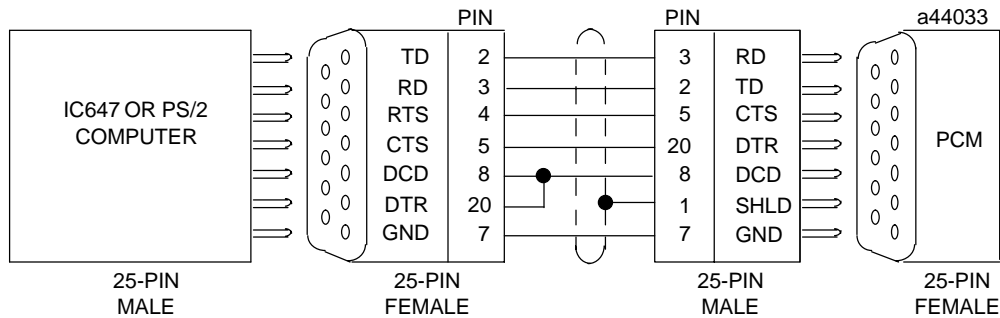

Figure 6. Wiring for PCM to IC647 Computer or PS/2 Cable (IC690CBL705)

Cables - PCM to Programmer

GFK-0359F
July 1995

Table 1. Other Documents to be Consulted

Title
Programming Software User's Manual for IC641 Software Products
Programmable Controller Reference Manual for IC697 Products
Programmable Coprocessor Module and Support Software User's Manual
Programmable Controller Installation Manual for IC697 Products
Programmable Controller Installation Manual for IC693 Products
Alphanumeric Display System User's Manual
Graphics Display System User's Manual

Table 2. Specifications for IB690CBL701/702/705 †

CableLength	10 feet (3 meters)
Connectors	
PCMSide	25-pin D-subminiature type: AMP 205208-1 or equivalent
ProgrammerSide	9-pin D-subminiature type: AMP 205203-1 or equivalent
CableClamps	
25-pin	AMP 207908-7 or equivalent
9-pin	AMP 207908-1 or equivalent
CableType	6 conductor, overall shield, non-paired AWG #24 (0.22 mm ²) type - Belden 9536 or equivalent

† Refer to GFK-0867B, or later for product standards and general specifications.

Table 3. Ordering Information

Description	Catalog Number
Cable, PCM to IC640 or PC-XT Computer- 10 feet (3 meters)	IC690CBL701
Cable, PCM to PC-AT Computer - 10 feet (3 meters)	IC690CBL702
Cable, PCM to IC647 or PS/2 Computer- 10 feet (3 meters)	IC690CBL705

The IC690ACC903 RS-485 Port Isolator replaces the IC655CMM590 Isolated Repeater/Converter (also referred to as the “Brick”). The device features 500 volts of isolation in a compact package servicing all IC693, IC697, and IC200 PLC product lines. The product connects directly to an RS-485 serial port or through a short extender cable provided with the device. The extension cable is intended for use in applications where direct connection to the port is obstructed by surrounding equipment or when it is not acceptable for the device to protrude from a PLC module. The Port Isolator can operate in either single- or multi-drop mode, which is selected by a slide switch on the top of the module.

The Port Isolator provides the following features:

- Four opto-isolated signal channels: SD, RD, RTS, and CTS
- Electrical compatibility with RS-485
- Single- or multi-drop operation
- Input termination consistent with standard for serial channels
- A 5V DC/DC converter for power isolation
- Hot insertion is supported

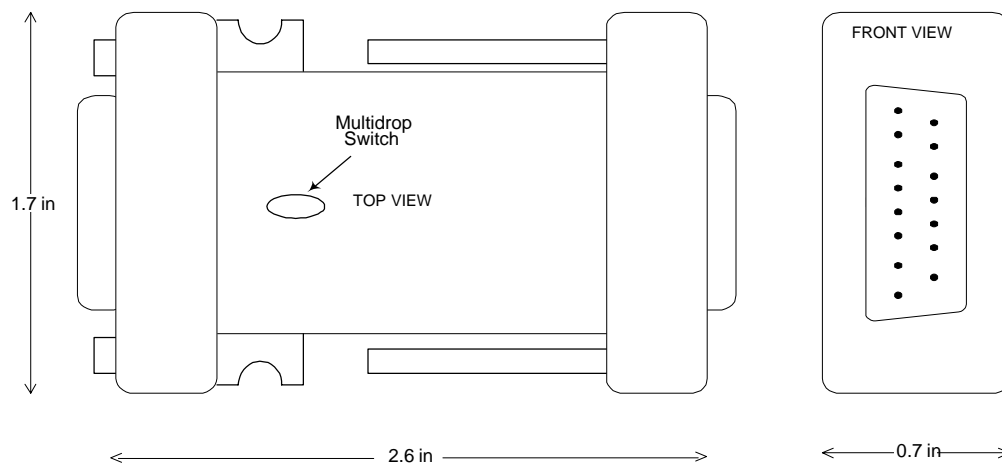

Figure 1. RS-485 Port Isolator

GFK-1663A
April 1999

RS-485 Port Isolator

Connectors

The Isolator provides two connectors, one 15 pin male D-type (PL1) and one 15 pin female D-type (PL2). The pin assignments are identical, except that pin 4 on PL2 is connected to the module ID resistor.

RS-485 Connectors

Connector	Pin	Pin Name	Pin Type	Description
PL1	1	SHLD	–	Chassis Ground
	2	NC	–	
	3	NC	–	
	4	NC	–	
	5	5V	–	+5V power
	6	CTS (A')	In	Clear to send –
	7	0V	–	Signal Ground
	8	RTS (B)	Out	Request to send +
	9	NC	–	
	10	SD (A)	Out	Send data –
	11	SD (B)	Out	Send data +
	12	RD (A')	In	Read data –
	13	RD (B')	In	Read data +
	14	CTS (B')	In	Clear to send +
	15	RTS (A)	Out	Request to send –

Connector	Pin	Pin Name	Pin Type	Description
PL2	1	NC	–	
	2	NC	–	
	3	NC	–	
	4	NC	–	
	5	5V	–	+5V power
	6	RTS (A)	Out	Request to send –
	7	0V	–	Signal Ground
	8	CTS (B')	In	Clear to send +
	9	RT	–	Terminating Resistor*
	10	RD (A')	In	Read data –
	11	RD (B')	In	Read data +
	12	SD (A)	Out	Send data –
	13	SD (B)	Out	Send data +
	14	RTS (B)	Out	Request to send +
	15	CTS (A')	In	Clear to send –

* Use the terminating resistor if the Port Isolator is used in port-to-port mode or at the end of a multi-drop configuration. To terminate the RD balanced line, place a jumper wire from pin 9 to pin 10.

* A denotes – and B denotes +. A and B denote outputs and A' and B' denote inputs.

Logic Diagram

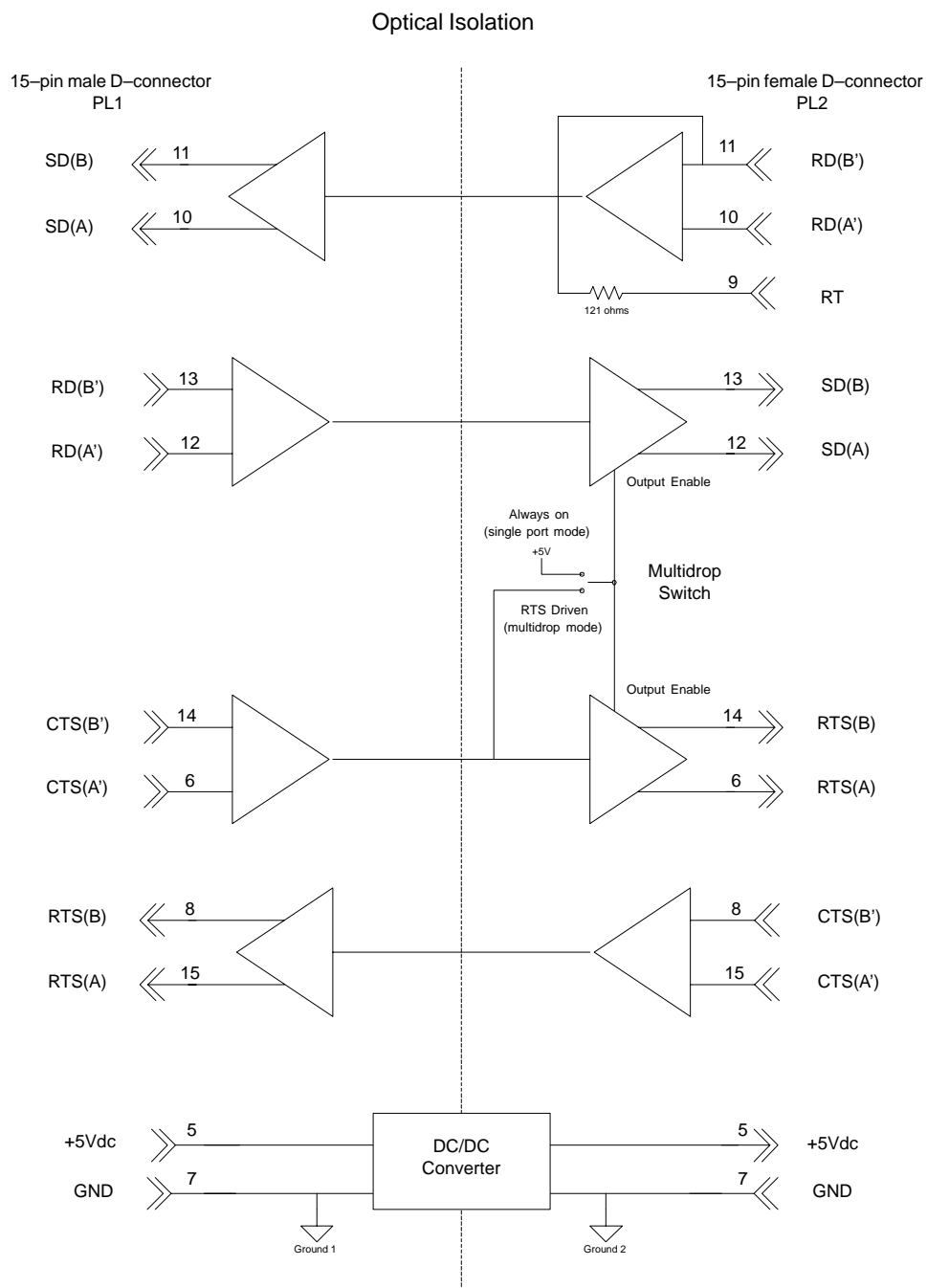

Figure 2. IC690ACC903 Block Diagram

Installation

The Isolator is packaged in a contoured plastic enclosure designed for either direct attachment to a serial port or through a 12" extender cable for panel mounted applications. Two M3 thumbscrews secure the device to its mating connector. The device can be easily inserted into an existing communication channel with no additional hardware. In Figure 3, the Isolator is shown connected directly to a CPU module. Alternatively, the Isolator can be mounted separately from the PLC system using the extender cable provided. For mounting separately to a panel, you will need to provide two #6-32 (4 mm) mounting screws (Figure 4).

When installing the Isolator, tighten the connector screws and panel mounting screws (if used) to the following torque values:

Screws	Type	Torque
Connector Thumbscrews (supplied with Isolator)	M3	8 in./lbs. (0.9 Newton-meter)
Panel Mounting Screws (user-supplied)	#6/32 (4 mm)	12 in./lbs. (1.4 Newton-meters)

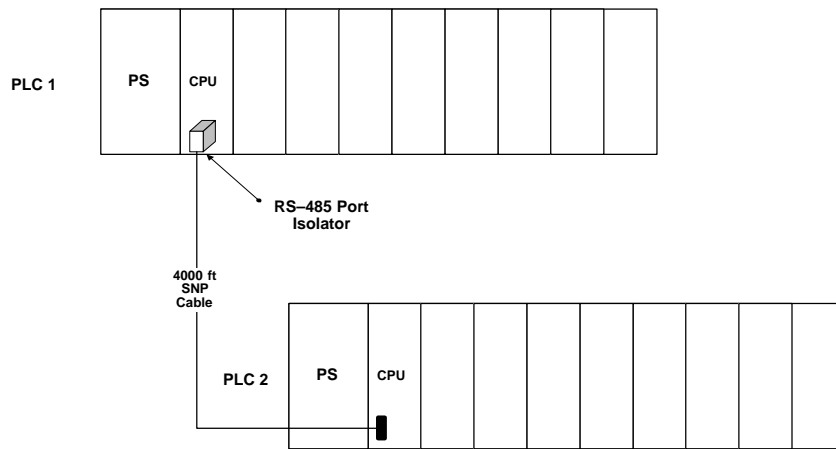

Figure 3. RS-485 Port Isolator in PLC Network

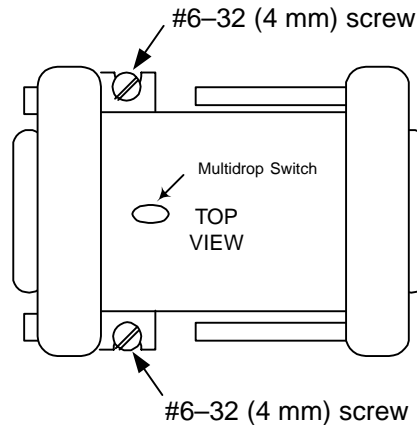

Figure 4. Mounting Port Isolator to Panel

RS-485 Port Isolator

GFK-1663A
April 1999

The RS485 Port Isolator supports both port-to-port and multi-drop configurations (Figure 5). For installation information, refer to section 3 of the Serial Communications User's Manual (GFK-0582). One configuration not covered in the User's Manual is the case where the Isolator is powered by a source other than the host port. This configuration is used to prevent an interrupt in communications if the host system requires a power cycle. It also prevents power loss to equipment using the port for power. For this, you will need to build a custom cable as shown in Figure 6.

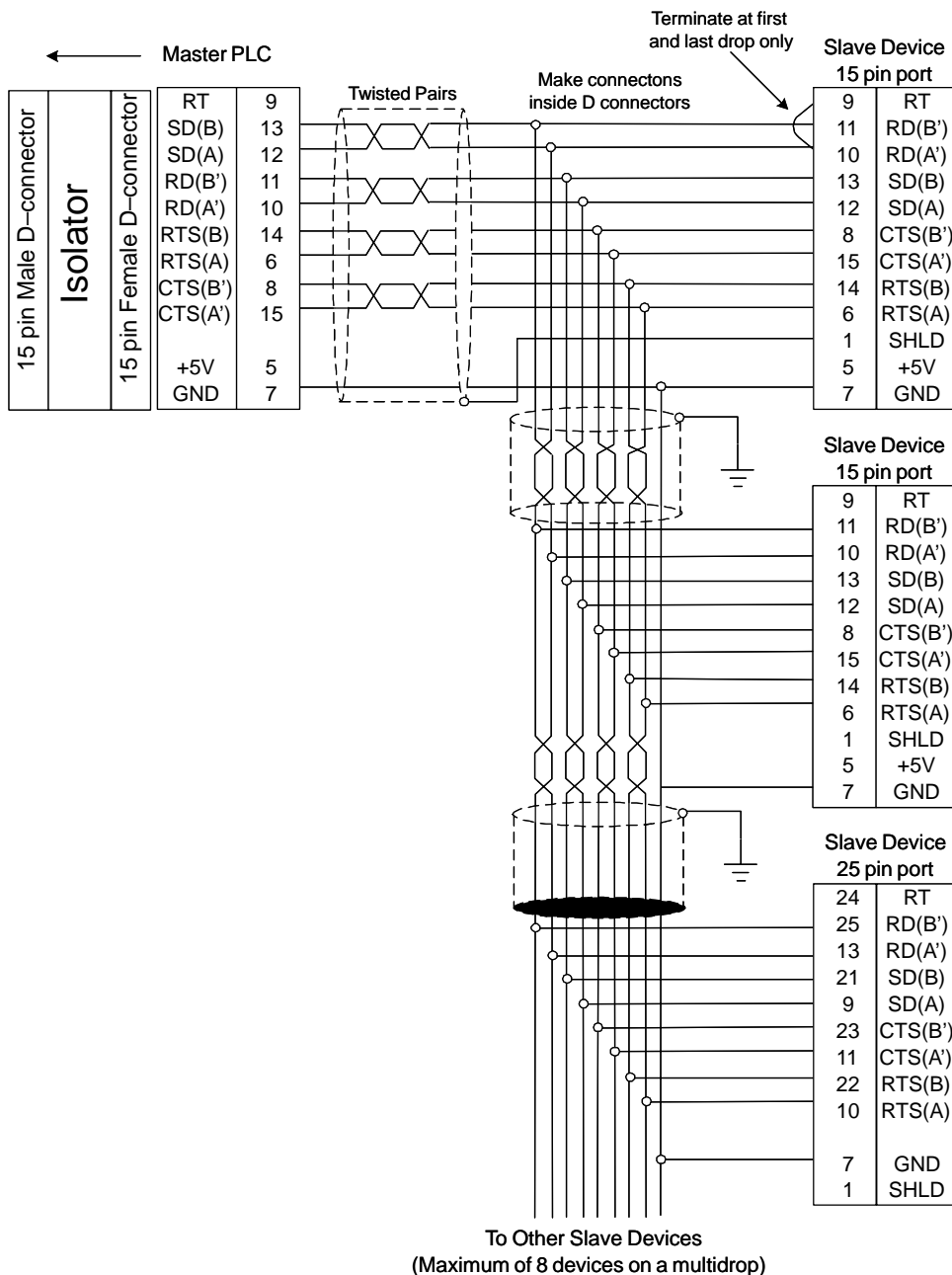

Figure 5. Multidrop Configuration Connecting Devices with 15-Pin Ports and 25-Pin Ports

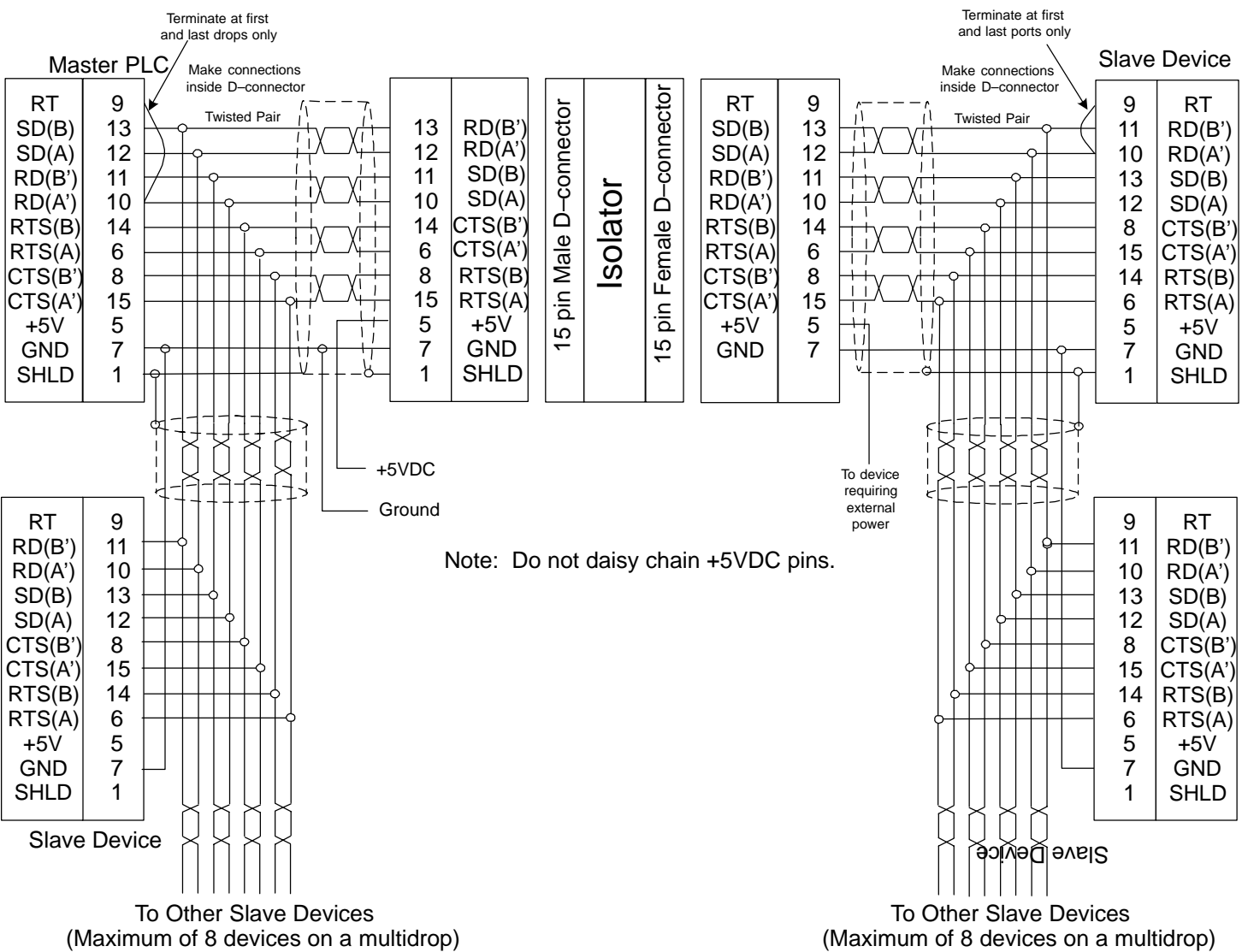

Figure 6. Cable for Supplying External Power Through the Port Isolator

RS-485 Port Isolator

GFK-1663A

April 1999

Specifications

Mechanical	
RS-485	15-pin D shell male for direct mounting to serial port on the programmable controller 15-pin D shell female for communication cable
Installation Hardware	Two M3 thread connector thumbscrews. Recommended torque: 8 in./lbs. (0.9 Newton-meter). These are supplied with Isolator. Two user supplied #6/32 (4mm) thread panel mounting screws. Recommended torque: 12 in./lbs. (1.4 Newton-meter)
Electrical	
Voltage Supply	+5VDC (supplied by port)
Typical Current	25 mA 100 mA available for external equipment
Ground Isolation	500 Volts
Conformance	EIA-422/485 Balanced Line
Operating Temperature	0° – 60°C (32° – 140° F)
Baud Rate	Those supported by PLC

GFK-0682C
May 1996

Miniconverter Kit

The Miniconverter Kit consists of an RS-422 (SNP) to RS-232 Miniconverter, a 6 foot (2 meter) serial extension cable, and a 9-pin to 25-pin Converter Plug assembly. The 15-pin SNP port connector on the Miniconverter plugs directly into the serial port connector on the programmable controller. The 9-pin RS-232 port connector on the Miniconverter connects to an RS-232 compatible device.

When used with an IBM® PC-AT, or compatible computer, one end of the extension cable plugs into the Miniconverter's 9-pin serial port connector, the other end plugs into the 9-pin serial port of the computer. The Converter plug (supplied with kit) is required to convert the 9-pin serial port connector on the Miniconverter to the 25-pin serial port connector on the IC647 computer, or an IBM PC-XT or PS/2® Personal Computer.

The IC640 industrial computer requires an additional adapter (not supplied - please contact your local PLC distributor) for use with the Miniconverter.

The pinout of the Miniconverter is shown in the following two tables. Table 1 is the pinout for the RS-232 port. The direction of signal flow is with respect to the Miniconverter.

Table 1. Miniconverter RS-232 Port

Pin	Signal Name	Direction
2	SD - Send Data	Output
3	RD - Receive Data	Input
5	GND - Ground	n/a
7	CTS - Clear To Send	Input
8	RTS - Request To Send	Output

The pinouts were chosen to allow direct connection (using a straight through, or 1 to 1 cable (as provided

with kit)) to the IBM PC-AT. Most IBM compatible computers equipped with an RS-232 port will provide a pinout compatible with the one shown above.

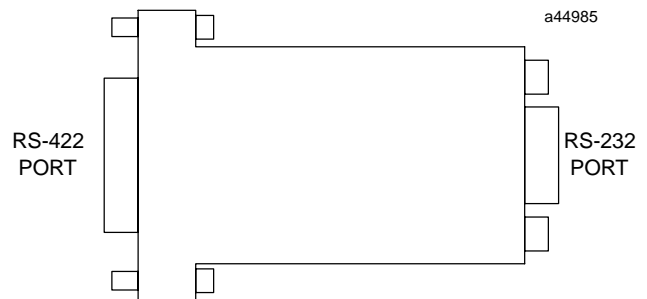

SNP Port to RS-232 Adapter

Table 2 is the pinout for the Miniconverter's RS-422 serial port. The direction of signal flow is also with respect to the Miniconverter.

Table 2. Miniconverter RS-422 Port

Pin	Signal Name	Direction
1	SHLD - Shield	n/a
5	+5 VDC - Power	Input
6	CTS(A') - Clear To Send	Input
7	GND - Ground	n/a
8	RTS(B) - Request To Send	Output
9	RT - Receive Termination	Output
10	SD(A) - Send Data	Output
11	SD(B) - Send Data	Output
12	RD(A') - Receive Data	Input
13	RD(B') - Receive Data	Input
14	CTS(B') Clear To Send	Input
15	RTS(A) - Request To Send	Output

©IBM and PS/2 are registered trademarks of International Business Machines Corporation

GFK-0682C
May 1996

Miniconverter Kit

System Configurations

The Miniconverter can be used in a point-to-point configuration as described above, or in a multidrop configuration with the host device configured as the master and one or more programmable controllers configured as slaves.

The multidrop configuration requires a straight through (1 to 1) cable from the Miniconverter's RS-422 port to the first slave PLC's SNP port. Other slaves will require a daisy chain connection between slaves. A maximum of eight devices can be connected in an RS-422 multidrop configuration.

All of the devices must have a common ground. If ground isolation is required, you can use the Isolated Repeater/Converter (IC655CCM590) in place of the Miniconverter.

When using the Miniconverter with a modem connection, it may be necessary to jumper RTS to CTS (consult the user's manual for your modem).

Cable Diagrams (Point-To-Point)

When connecting the Miniconverter to IBM PC and compatible computers with hardware handshaking, the following cable connections should be used.

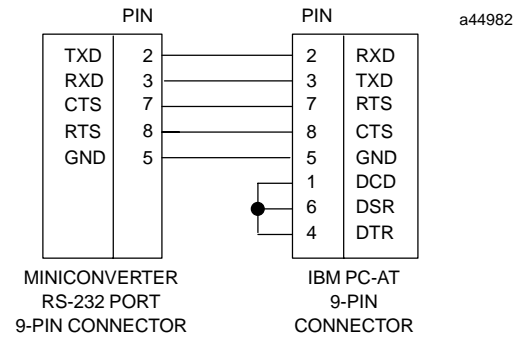

Figure 1. Miniconverter to PC-AT

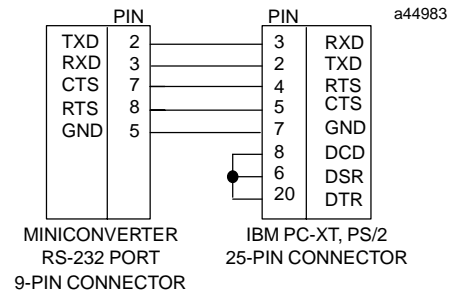

Figure 2. Miniconverter to IC647 computer, PC-XT, PS/2

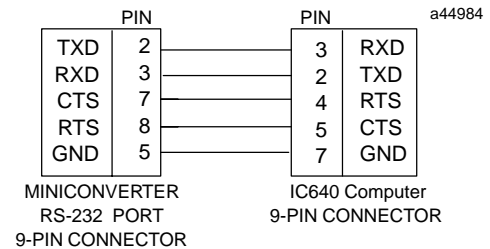

Figure 3. Miniconverter to 9-Pin IC640 Computer or PC-XT Computer (Additional Adapter Required)

Table 3. Miniconverter Specifications

Mechanical:	
RS-422	15-pin D shell male for direct mounting to serial port on the programmable controller
RS-232	9-pin D shell male for connection to RS-232 serial port of an IC647 industrial computer or Personal Computer.
Electrical and General:	
Voltage Supply	+5 VDC (supplied by PLC power supply)
Typical Current	Version A (IC690ACC901A) - 150 mA Version B (IC690ACC901B) - 100 mA
Operating Temperature	0° to 70° C (32° to 158° F)
Baud Rate	38.4K Baud maximum
Conformance	EIA-422 (Balanced Line) or EIA-423 (Unbalanced Line)
Ground Isolation	Not provided

GFK-0589A
December 1993

Blank Slot Interrupt Jumper

Features

- Allows slot to be reserved for future expansion
- Provides for continuation of interrupt signal through empty slot on an IC697 PLC rack backplane
- Single connector mounted on board
- Easy connection to mating backplane connector

Functions

The Blank Slot Interrupt Jumper, IC697ACC722, for the IC697 PLC is an accessory which has been designed to allow you to reserve a slot in the IC697 standard rack for future expansion. This jumper, when installed in a blank slot, allows for continuation of the interrupt signal through the backplane. Use of this board is required when there are modules installed to its right which may interrupt the CPU.

Installation

Be sure that power to the rack is turned off before attempting any hardware installation. The Blank Slot Interrupt Jumper can be installed in an IC697 CPU rack or expansion rack in slots 2 through 8 of a nine-slot rack or slots 2 through 4 of a five-slot rack. It is not necessary to reserve the last slot (slot 9 in a nine-slot rack or slot 5 in a five-slot rack) in a rack. Also, a rack will not operate properly if this jumper is installed in slot 1. For additional information on installation refer to the applicable *Programmer Controller Installation manual*.

Note

The Blank Slot Interrupt Jumper, when installed, must be added to the system configuration using the IC641 Programming Software configuration function (see reference 2).

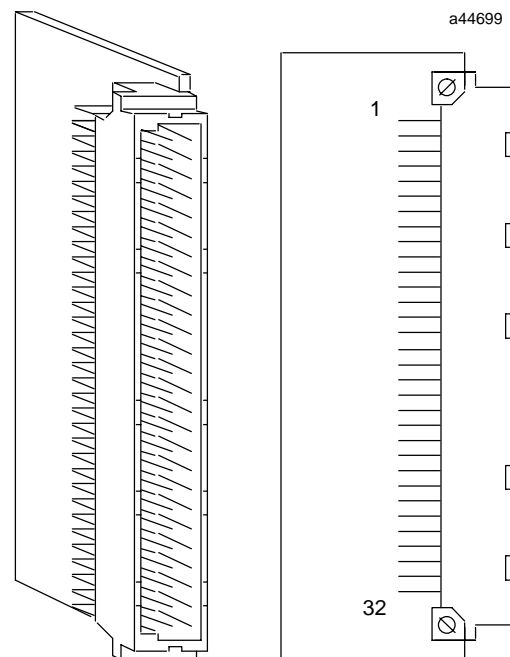

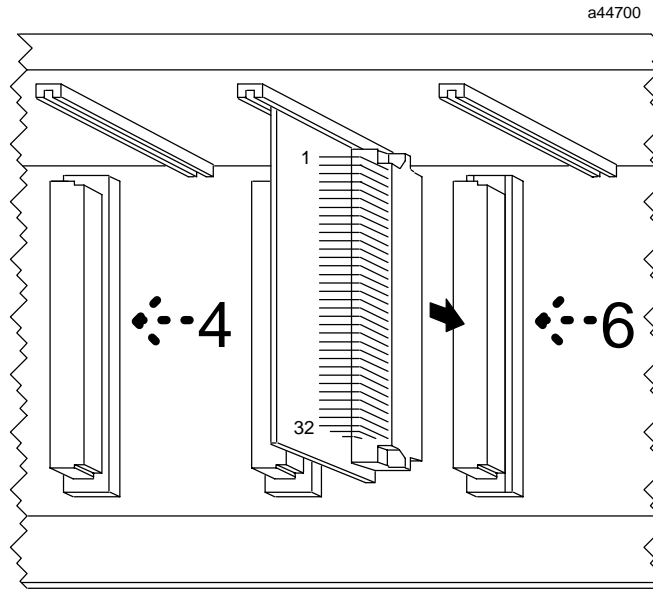

Figure 1. Installation of Blank Slot Interrupt Jumper

Configuration Considerations

If version 2.05 or earlier of the IC641 Programming Software configuration function is being used it is recommended that the Blank Slot Interrupt Jumper be configured as a Bus Transmitter Module

WARNING: Configuration mismatch exists - see fault tables

In addition, a "Loss of" fault will be logged into the appropriate fault table.

A future version of the IC641 Programming Software configuration function will include a selection for the Blank Slot Interrupt Jumper, IC697ACC722 on the

(IC697BEM713), although any module may be used to reserve the slot. When the Blank Slot Interrupt Jumper is configured as a BTM (or any other module) and is stored to the PLC, the following message will appear on the programmer's screen:

screen accessed by the **F8 - other** function key. When the Blank Slot Interrupt Jumper is configured in this future version and later versions there will not be a mismatch when the configuration is stored to the PLC.

Table 1. References

Reference	Title
1	ProgrammableController Installation Manual
2	ProgrammingSoftware User's Manual
3	ProgrammableController Reference Manual

Table 2. Ordering Information

Description	Catalog Number
Blank Slot Interrupt Jumper Assembly (qty 6)	IC697ACC722

GFK-1187A
July 1995

Cable Shield Clamping Assembly

Features

- Provides for higher EMC (Electromagnetic Compatibility) immunity for shielded cables
- Use for installations in severe industrial environments
- Use with all IC69* PLC products
- Easy to assemble
- Mounts on panel, rack enclosure, or directly onto an IC697 rack

Functions

The *Cable Shield Clamping Assembly*, IC697ACC736, contains the parts necessary in order to provide higher

EMC immunity for shielded cables in PLC installations in severe industrial environments.

The Cable Shield Clamping Assembly must be used in severe industrial environments to provide higher EMC immunity for shielded cables. Shield grounding is accomplished using the ground plate and cable clamps provided in the kit.

The Cable Shield Clamping Assembly package includes:

- *One Ground Plate*
- *Six Cable Clamps*
- *Four #6 self-tapping screws.*

Figure 1 is an outline drawing of the mounting plate showing dimensions required for mounting. The figure also shows a cable clamp.

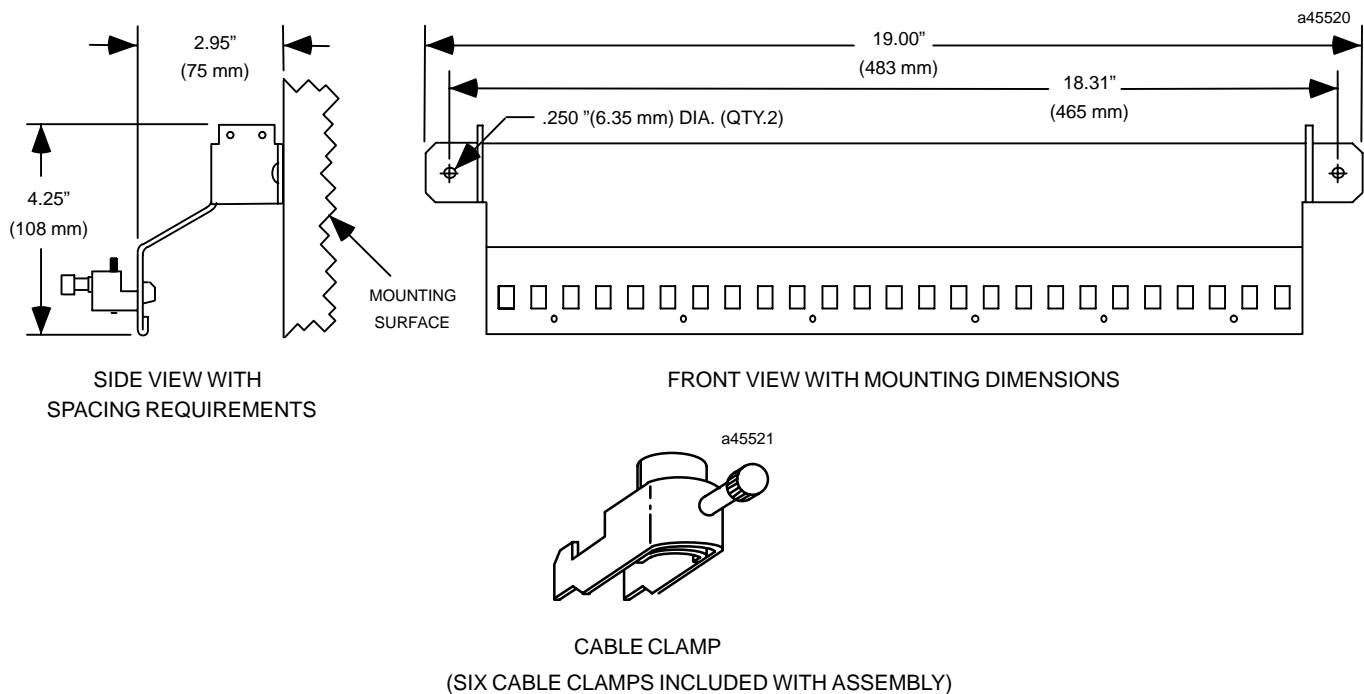

* Additional cable clamps available (12 per package), Catalog Number IC697ACC737.

Figure 1. Ground Plate Outline, Mounting Dimensions, and Cable Clamp

GFK-1187A
July 1995

Cable Shield Clamping Assembly

Installing the Assembly

The ground plate should be mounted near the PLC rack for both IC697 and IC693 PLC installations. The cable clamp provides mechanical relief as well as electrical grounding. A typical installation is shown in Figure 2 below. Figure 5 on the next page shows the Cable Clamp Assembly installed on an IC697 PLC rack.

The cable clamp attaches to the ground plate by sliding it into two adjacent slots at the selected location for the cable. The cable is inserted between the ground plate and the cable clamp after removing the required section of the cable's outer cover. Tighten

the cable clamp by turning the thumbscrew clockwise. *Do not overtighten the thumbscrew - handtighten or tighten lightly with a tool.*

Note

If you are installing the ground plate on a painted surface, the paint must be removed where the ground plate is to be mounted to ensure a good ground connection between the plate and mounting surface.

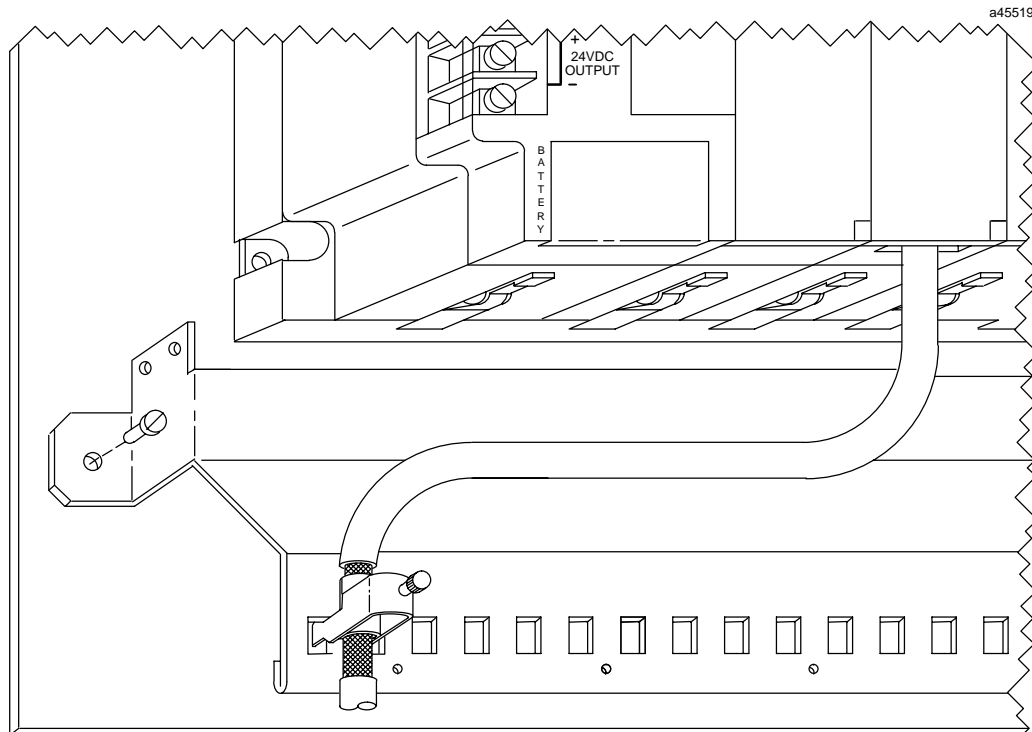

Figure 2. Example of Cable Shield Clamping Assembly Installation

Cable Shield Clamping Assembly

GFK-1187A
July 1995

The maximum diameter cable that can be used with the cable clamp is 0.51 inches (13mm) as shown below in Figure 3.

The insulating cover on the shielded cable must be removed to allow maximum contact between the cable shield and the cable clamp as shown in Figure 4.

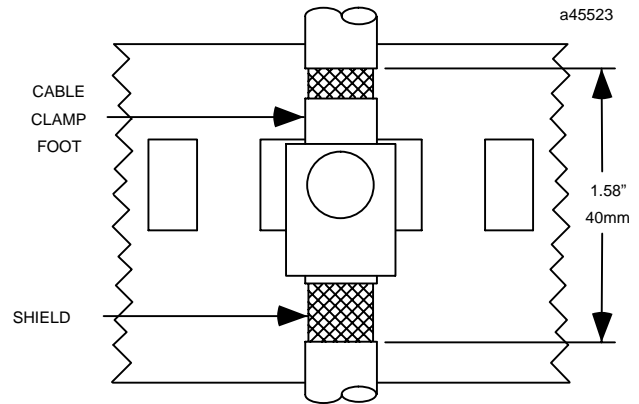
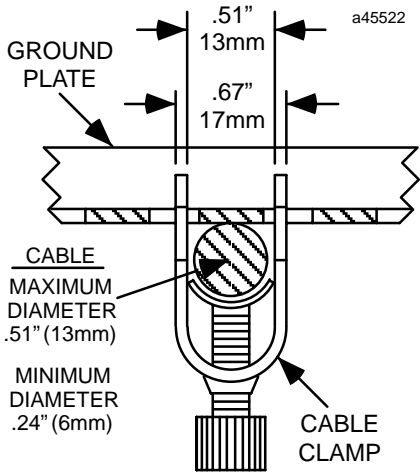

Figure 3. Cross Section of Cable Secured by Clamp

Figure 4. Clamped Cable with Exposed Shield

In addition to mounting to a flat surface near the PLC system, the Cable Shield Clamping Assembly can be optionally attached directly to an IC697 rack as shown below. For compatibility, the following versions of racks are required for the Cable Shield Clamping Assembly:

- IC697CHS790E, or later version
- IC697CHS791E, or later version
- IC697CHS782C, or later version
- IC697CHS783C, or later version

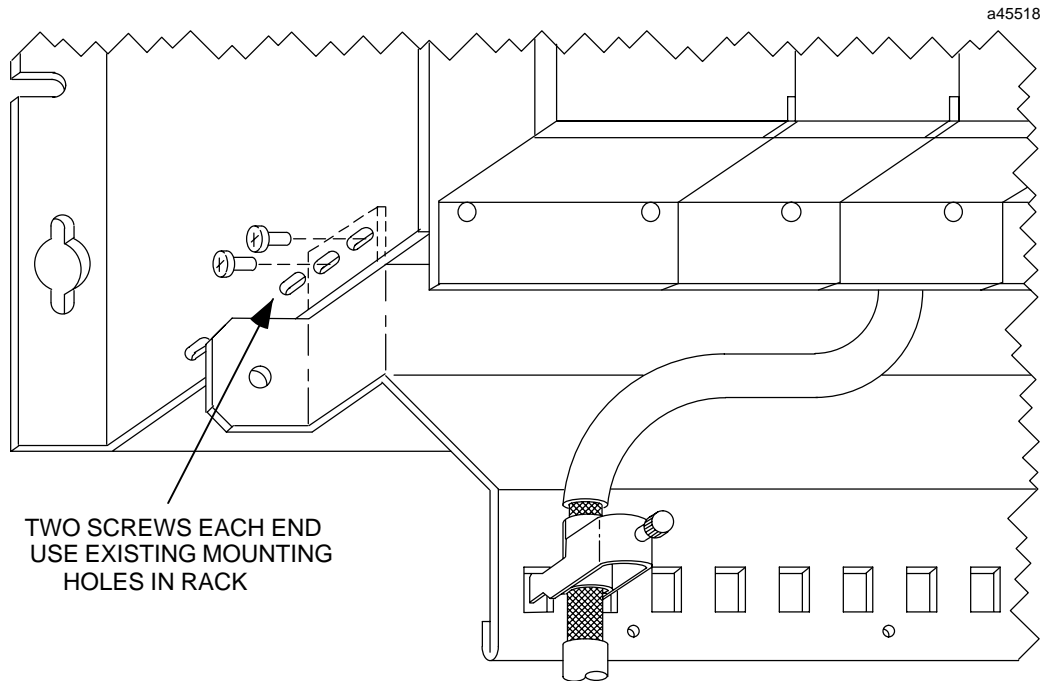

Figure 5. Cable Shield Clamping Assembly Mounted on an IC697 Rack

GFK-0552C
August 1995

VME Option Kit

This instruction sheet provides the information for installation of the **VME Option Kit**, catalog number IC697ACC715, which allows you to add a J2 VME backplane (which has P2 connectors) to an IC697 PLC rack.

Contents of VME Option Kit

Description	Qty
Connector jumper	6
M2.5 threaded strip	2
Aluminum spacer	4
VME slot filler	4
Phillips screws, M2.5 x 8	24
Spring lock washers	24
Hex nuts, M2.5	12
Power cable	1
Ribbon cable connector mounting bracket	6
Manual, <i>User's Guide to Integration of 3rd Party VME Modules</i>	1

Note

This kit **does not** contain a J2 backplane. This must be purchased from a 3rd party.

You will need these items

1. Phillips head screwdriver
2. A five-slot or nine-slot IC697 rack with one of the following catalog numbers:
IC697CHS750, five-slot rear (panel) mount
IC697CHS790, nine-slot rear (panel) mount
IC697CHS791, nine-slot front (rack) mount
3. A J2 backplane (has P2 connectors)
4. Any VME module that has both a P1 and P2 connector
5. User supplied rack mounting hardware (Qty. 4 - 1 1/4 inch x #10-32 or #12-28 screws).

Follow these steps

1. Unpack and check all of the items in the kit. Verify with the parts list that each item is present.
2. Place the selected rack on its side supported in such a way that it is straight and level.
3. Locate the slot in the rear bottom rail of the rack. Locate one of the threaded metal strips included in the kit. The strips are made to fit the nine-slot racks (IC697CHS790, IC697CHS791) but can be modified to fit the five-slot rack (IC697CHS750).

Slide the threaded strip into the slot in the bottom rail of the rack; it should slide easily. *If you have a five-slot rack*, slide the threaded strip in until it covers the entire length of the rail and snap the excess off at the last threaded hole at the top of the rail.

Note

If your rack has no side access to the lower and middle rail, the side plate must be removed. This is done by removing the screws in the side plate.

In order to mount the J2 backplane, you must remove the rear cover. To do this, remove the 12 screws (6 top and 6 bottom) holding the cover on. After removing the cover, **be sure to reinstall 6 of these screws back into the J1 backplane**. You can discard the rear cover.

4. Locate the slot in the center rail of the rack. Install the threaded strip in the center rail using the same procedure described in step 3. If you removed the rack side plate, you must reinstall it at this time.
5. Plug the standard VME module into the rack in a slot that you will want the J2 backplane to span.
6. In this step you are using the standard VME module to align the J2 backplane. *Gently* plug the middle connector of your VME J2 backplane into the P2 connector of the VME module - be sure that the alignment is correct.

GFK-0552C
August 1995

VME Option Kit

7. Secure the J2 backplane to the threaded strips using the pan-head screws and lock washers provided in the kit.
8. Plug the power cable provided with the kit into the nine-pin connector on the side of the rack. Connect the ends of the cable to the saddle clamps on the back of the J2 backplane. Make sure that you connect the +5V lead to the saddle clamp marked +5V and the GND lead to the saddle clamp marked GND.
9. If your rack is a panel mount rack (IC697CHS790 or IC697CHS750), you must use the spacers provided in the kit to be sure that the wire-wrap pins used in some J2 backplanes do not come in contact with the mounting panel. The use of spacers will require you to use longer mounting hardware.
10. Jumpers are provided so that, if required, you can configure any slot (except slot 1) of the rack to function as a normal VME slot. Place four of the jumpers on the pins in the backplane for the slot you wish to configure.
11. Blank Slot Fillers (catalog number IC697ACC720) are available that will cover any openings left between standard VME modules and other modules in the rack.

J2 Installation Alternative

- Six J2 connector ribbon cable mounting brackets are included in this kit for use as an alternative to mounting the J2 backplane. A J2 connector attached to a ribbon cable can be mounted on this bracket. This cable provides the external I/O connections to a VME module in an IC697 rack.
- Mount the J2 connector attached to the ribbon cable on the ribbon cable mounting bracket and secure with screws, lock washers and hex nuts provided in the kit.
- Install the ribbon cable mounting bracket loosely at the selected slot location.
- With the VME module plugged into the J2 connector, align the bracket and tighten the mounting screws.

A

Accessories

- Blank Slot Interrupt Jumper IC697ACC722, 80-1*
- Cable Shield Clamp Assem IC697ACC736, 81-1*
- Cable, PCM IC697CBL701/702/705, 77-1*
- Cables, I/O, 75-1*
- Miniconverter Kit IC690ACC901, 79-1*
- RS-485 Port Isolator IC690ACC903, 78-1*
- VME Option Kit IC697ACC715, 82-1*
- AD697SPL711, State Logic Processor, 60-1
- Analog Input System, 57-1
- Analog Output System, 58-1
- Approvals, 2-1

B

- Base Converter Module, 57-1
- Battery Safety, 3-1
- Blank Slot Interrupt Jumper, 80-1
- Bus Controller Module, 61-1
- Bus Expansion Modules
 - Bus Controller IC697BEM731/734, 61-1*
 - Bus Receiver IC697BEM711, 64-1*
 - Bus Transmitter IC697BEM713, 63-1*
 - FIP Bus Controller IC697BEM742, 62-1*
 - FIP Bus Controller IC697BEM744, 62-1*
 - I/O Link Interface IC697BEM721, 66-1*
 - Interface for IC600 PLC IC697BEM761, 67-1*
 - Remote I/O Scanner IC697BEM733/735, 65-1*
- Bus Receiver Module, 64-1
- Bus Transmitter Module, 63-1

C

- Cable Shield Clamping Assembly, 81-1
- Cables, Power Supply Expansion, 76-1
- Cables, I/O, 75-1
- Cables, PCM to Programmer, 77-1
- Communications Coprocessor Module, 71-1
- Communications Modules
 - Communications Coprocs IC697CMM711, 71-1*
 - Ethernet Controller IC697CMM741, 68-1*
 - Ethernet Interface (Type 2) IC697CMM742, 69-1*
 - Redundancy Comms IC697RCM711, 72-1*
 - Serial Comms, State Logic IC697CMM712, 70-1*
- Coprocessor Modules
 - Alphanumeric Display IC697ADC701, 35-1*
 - PCM IC697PCM711, 34-1*

CPUs

- 12 MHz 32 Kbyte IC697CPU731, 12-1*
 - 12 MHz Expandable FI Pt IC697CPU772, 14-1*
 - 12 MHz Expandable IC697CPU771, 13-1*
 - 16 MHz 32 Bit Expan. FI Pt IC697CPU782, 16-1*
 - 16 MHz 32 Bit Expandable IC697CPU781, 15-1*
 - 16 MHz 32 Bit FI Pt Hot Stby IC697CPU780, 28-1*
 - 16 MHz 32 Bit FI Pt State Lgc IC697CSE784, 29-1*
 - 16 MHz 32 Bit, TMR IC697CPU788, 25-1*
 - 16 MHz 32 Bit, TMR IC697CPU789, 26-1*
 - 32 MHz 32 Bit FI Pt 1 Mb IC697CPM915, 17-1*
 - 64 MHz 32 Bit FI Pt 1 Mb IC697CPM925, 18-1*
 - 64 MHz 32 Bit FI Pt 1 Mb State Logic IC697CSE925, 31-1*
 - 64 MHz 32 Bit FI Pt 1 Mb, TMR IC697CPM790, 27-1*
 - 64 MHz 32 Bit FI Pt State Lgc IC697CSE924, 30-1*
 - 96 MHz 32 Bit FI Pt 1 Mb Fast, IC697CPX935, 22-1*
 - 96 MHz 32 Bit FI Pt 1 Mb Hot Stby IC697CGR935, 24-1*
 - 96 MHz 32 Bit FI Pt 1 Mb memory, IC697CPX782, 20-1*
 - 96 MHz 32 Bit FI Pt 512 Kb Hot Stby IC697CGR772, 23-1*
 - 96 MHz 32 Bit FI Pt 512 Kb memory, IC697CPX772, 19-1*
 - 96 MHz 32 Bit FI Pt 6 Mb Medium, IC697CPX928, 21-1*
- Current Expander Module, 57-1

D

Discrete Input Modules

- 12 VAC 32 Pt IC697MDL252, 36-1*
- 12 VDC Pos/Neg IC697MDL652, 43-1*
- 120 VAC 16 Pt IC697MDL251, 41-1*
- 120 VAC 32 Pt IC697MDL250, 39-1*
- 120 VAC Isol 16 Pt IC697MDL240, 40-1*
- 125 VDC Pos/Neg Logic IC697MDL640, 46-1*
- 24 VAC 32 Pt IC697MDL253, 37-1*
- 24 VDC Pos/Neg Logic IC697MDL653, 44-1*
- 240 VAC Isol IC697MDL241, 42-1*
- 48 VAC 32 Pt IC697DL254, 38-1*
- 48 VDC Pos/Neg Logic IC697MDL654, 45-1*
- Interrupt IC697MDL671, 48-1*
- TTL Neg Logic 32 Pt IC697MDL651, 47-1*

Discrete Output Modules

- 12 VDC 0.5A IC697MDL752, 53-1*
- 120 VAC 0.5A IC697MDL350, 49-1*
- 120 Volt AC 2A IC697MDL340, 50-1*
- 120/240 VAC 2A Isol IC697MDL341, 51-1*
- 24/48 VDC, 0.5A IC697MDL750, 54-1*
- 24/48 VDC, 2A IC697MDL740, 55-1*
- 5/48 VDC 0.5A Neg IC697MDL753, 52-1*
- Relay 16 Pt IC697MDL940, 56-1*

E

Ethernet Controller Module, 68-1
Ethernet Interface (Type 2) Module, 69-1
Expansion Memory
 32 Bit CMOS IC697MEM731/32/33/35, 33-1
 CMOS IC697MEM713/15/17/19, 32-1

F

FIP Bus Controller Module, 62-1

G

GEK-83517, I/O Cables, 75-1
GFK-0079, Standard Racks, 4-1
GFK-0081, Output Module 120 VAC 0.5A, 49-1
GFK-0082, Output Module 120 VAC 2A, 50-1
GFK-0084, Input Module 120 VAC 32 Pt, 39-1
GFK-0085, Output Mdl 24/48 VDC 0.5A, 54-1
GFK-0086, Output Mdl 24/48 VDC 2A, 55-1
GFK-0096, Interface for IC600 PLC, 67-1
GFK-0153, Power Supply Expansion Cable, 76-1
GFK-0159, CPU 12 MHz 32Kbyte, 12-1
GFK-0160, CMOS Expansion Memory, 32-1
GFK-0161, Bus Transmitter Module, 63-1
GFK-0162, Bus Receiver Module, 64-1
GFK-0164, PCM, 34-1
GFK-0165, Bus Controller, 61-1
GFK-0166, WorkstationIntXT/AT, 73-1
GFK-0281, WorkstationIntPS/2, 74-1
GFK-0349, CPU 12 MHz Expandable, 13-1
GFK-0359, Cable, PCM, 77-1
GFK-0370, Comms Coprocessor, 71-1
GFK-0375, Input Module 120 VAC Isol, 40-1
GFK-0376, Input Module 240 VAC Isol, 42-1
GFK-0377, Input Module Neg Logic TTL, 47-1
GFK-0378, Input Mdl 12 VDC Pos/Neg, 43-1
GFK-0379, Input Mdl 24 VDC Pos/Neg, 44-1
GFK-0380, Input Mdl 48 VDC Pos/Neg, 45-1
GFK-0381, Output Module 12 VDC 0.5A, 53-1
GFK-0382, Out. 120/240 VAC 2A Isol, 51-1
GFK-0383, Out. Mdl 5/48 VDC 0.5A Neg, 52-1
GFK-0384, Output Mdl 16 Pt Relay, 56-1
GFK-0385, Analog Input System, 57-1
GFK-0388, Analog Output Module, 58-1
GFK-0521, Alphanumeric Display Copr., 35-1
GFK-0531, CMOS Exp Mem 32 bit, 33-1
GFK-0532, Ethernet Controller, 68-1
GFK-0539, Remote I/O Scanner, 65-1
GFK-0552, VME Option Kit, 82-1
GFK-0588, CPU 12 MHz Expan. Fl Pt, 14-1
GFK-0589, Blank Slot Interrupt Jumper, 80-1
GFK-0626, Power Supply Adapter, 11-1
GFK-0637, Rack Fan Assembly, 6-1
GFK-0645, I/O Link Interface, 66-1
GFK-0682, Miniconverter Kit, 79-1
GFK-0684, VME Racks, 5-1
GFK-0718, Input Module 120 VAC, 41-1
GFK-0719, Input Mdl 125 VDC Pos/Neg, 46-1
GFK-0734, State Logic Processor, 60-1
GFK-0756, Input Module 12 VAC, 36-1
GFK-0757, Input Module 24 VAC, 37-1
GFK-0766, CPU 16 MHz 32 Bit Expan., 15-1
GFK-0767, CPU 16 MHz 32 Bit Exp. Fl Pt, 16-1
GFK-0784, Input Module 48 VAC, 38-1
GFK-0806, CPU 16 MHz 32 Bit, TMR, 25-1
GFK-0807, CPU 16 MHz 32 Bit, TMR, 26-1
GFK-0834, Redundancy Comms, 72-1
GFK-0837, CPU 16 MHz 32 Bit Fl Pt Hot Stby, 28-1
GFK-0867, Approvals and Specifications, 2-1
GFK-0880, Input Module 14 Pt Intrpt, 48-1
GFK-1002, FIP Bus Controller, 62-1
GFK-1035, CPU 16 MHz 32 Bit Fl Pt State Lgc, 29-1
GFK-1036, CPU 64 MHz 32 Bit Fl Pt State Lgc, 30-1
GFK-1039, Serial Comms, State Logic, 70-1
GFK-1047, Pwr Sply 24VDC 90W, 7-1
GFK-1057, High Speed Counter, 59-1
GFK-1061, Pwr Sply 48VDC 90W, 8-1
GFK-1119, CPU 32 MHz 32 Bit Fl Pt 1 Mb, 17-1
GFK-1120, CPU 64 MHz 32 Bit Fl Pt 1 Mb, 18-1
GFK-1167, CPU 64 MHz 32 Bit Fl Pt 1 Mb State Logic, 31-1
GFK-1187, Cable Shield Clamp Assem., 81-1
GFK-1215, CPU 64 MHz 32 Bit Fl Pt 1 Mb, TMR, 27-1
GFK-1309, Ethernet Interface (Type 2), 69-1
GFK-1388, Pwr Sply 55W 120/240VAC, 125 VDC, Version H (or later), 9-1
GFK-1437, CPU 96 MHz 32 Bit, 512 Kb Fast, Fl Pt CPU Redun, 23-1
GFK-1439, CPU 96 MHz 32 Bit, 1 Mb Fast, Fl Pt CPU Redun, 24-1
GFK-1448, Pwr Sply 100W 120/240VAC, 125 VDC, Version H (or later), 10-1
GFK-1663A, RS-485 Port Isolator, 78-1
GFK-1429F, CPU 96 MHz 32 Bit Fl Pt 512 Kb memory, 19-1
GFK-1431E, CPU 96 MHz 32 Bit Fl Pt 1 Mb memory, 20-1

GFK-1433, CPU 96 MHz 32 Bit Fl Pt 6 Mb Medium, 21-1
 GFK-1435, CPU 96 MHz 32 Bit Fl Pt 1 Mb Fast, 22-1
 GFT-102, ISO 9000 Registration, 1-1

H

High Speed Counter, 59-1

I

I/O Cables, 75-1
 I/O Link Interface Module, 66-1
 IC/CE697PWR724, Pwr Sply 24 VDC 90W, 7-1
 IC/CE697PWR748, Pwr Sply 48 VDC 90W, 8-1
 IC640WMI910/310, Workstation Int XT/AT, 73-1
 IC640WMI920/320, Workstation Int PS/2, 74-1
 IC687MDL940, Output Mdl 16 Pt Relay, 56-1
 IC690ACC901, Miniconverter Kit, 79-1
 IC690ACC903, RS-485 Port Isolator, 78-1
 IC690CBL701/702/705, Cable, PCM, 77-1
 IC697ACC715, VME Option Kit, 82-1
 IC697ACC721/724/744, Rack Fan Assembly, 6-1
 IC697ACC722, Blank Slot Interrupt Jumper, 80-1
 IC697ACC736, Cable Shield Clamp Assem, 81-1
 IC697ADC701, Alpha. Disp. Coprocessor, 35-1
 IC697ALG230, Base Converter Module, 57-1
 IC697ALG320, Analog Output Module, 58-1
 IC697ALG440, Current Expander Module, 57-1
 IC697ALG441, Voltage Expander Module, 57-1
 IC697BEM711, Bus Receiver, 64-1
 IC697BEM713, Bus Transmitter, 63-1
 IC697BEM721, I/O Link Interface, 66-1
 IC697BEM731/734, Bus Controller, 61-1
 IC697BEM733/735, Remote I/O Scanner, 65-1
 IC697BEM742, FIP Bus Controller, 62-1
 IC697BEM744, FIP Bus Controller, 62-1
 IC697BEM761, Interface for IC600 PLC, 67-1
 IC697CBL700/713, Power Supply Ext. Cable, 76-1
 IC697CGR772, CPU 96 MHz 32 Bit, 512 Kb, Fl Pt, CPU Redun, 23-1
 IC697CGR935, CPU 96 MHz 32 Bit, 1 Mb Fast, Fl Pt, CPU Redun, 24-1
 IC697CHS750, Rack Five Slot Rear Mnt, 4-1
 IC697CHS782/783, VME Racks, 5-1
 IC697CHS790, Rack Nine Slot Rear Mnt, 4-1
 IC697CHS791, Rack Nine Slot, Front Mnt, 4-1
 IC697CMM711, Communications Coprocs, 71-1
 IC697CMM712, Serial Comms, State Logic, 70-1
 IC697CMM741, Ethernet Controller, 68-1
 IC697CMM742, Ethernet Interface (Type 2), 69-1
 IC697CPM790, CPU 64 MHz 32 Bit Fl Pt 1 Mb, TMR, 27-1
 IC697CPM915, CPU 32 MHz 32 Bit Fl Pt 1 Mb, 17-1
 IC697CPM925, CPU 64 MHz 32 Bit Fl Pt 1 Mb, 18-1
 IC697CPU731, CPU 12 MHz 32 Kbyte, 12-1
 IC697CPU771, CPU 12 MHz Expandable, 13-1
 IC697CPU772, CPU 12 MHz Expand. Fl Pt, 14-1
 IC697CPU780, CPU 16 MHz 32 Bit Fl Pt Hot Stby, 28-1
 IC697CPU781, CPU 16 MHz 32 Bit Expan., 15-1
 IC697CPU782, CPU 16 MHz 32 Bit Exp. Fl Pt, 16-1
 IC697CPU788, CPU 16 MHz 32 Bit, TMR, 25-1
 IC697CPU789, CPU 16 MHz 32 Bit, TMR, 26-1
 IC697CPX772, CPU 96 MHz 32 Bit Fl Pt 512 Kb memory, 19-1
 IC697CPX782, CPU 96 MHz 32 Bit Fl Pt 1 Mb memory, 20-1
 IC697CPX928, CPU 96 MHz 32 Bit Fl Pt 6 Mb Medium, 21-1
 IC697CPX935, CPU 96 MHz 32 Bit Fl Pt 1 Mb Fast, 22-1
 IC697CSE784, CPU 16 MHz 32 Bit Fl Pt State Lgc, 29-1
 IC697CSE924, CPU 64 MHz 32 Bit Fl Pt State Lgc, 30-1
 IC697CSE925, CPU 64 MHz 32 Bit Fl Pt 1 Mb State Logic, 31-1
 IC697HSC700, High Speed Counter, 59-1
 IC697MDL240, Input Mdl 120 VAC Isol, 40-1
 IC697MDL241, Input Mdl 240 VAC Isol, 42-1
 IC697MDL250, Input Module 120 VAC, 39-1
 IC697MDL251, Input Module 120 VAC, 41-1
 IC697MDL252, Input Mdl 12 VAC, 36-1
 IC697MDL253, Input Module 24 VAC, 37-1
 IC697MDL254, Input Module 48 VAC, 38-1
 IC697MDL340, Output Mdl 120 VAC 2A, 50-1
 IC697MDL341, Out. 120/240 VAC 2A Isol, 51-1
 IC697MDL350, Output Mdl 120 VAC 0.5A, 49-1
 IC697MDL640, Input 125 VDC Pos/Neg, 46-1
 IC697MDL651, Input Mdl Neg Logic TTL, 47-1
 IC697MDL652, Input 12 VDC Pos/Neg, 43-1
 IC697MDL653, Input 24 VDC Pos/Neg, 44-1
 IC697MDL654, Input 48 VDC Pos/Neg, 45-1
 IC697MDL671, Input Module 14 Pt Intrpt, 48-1
 IC697MDL740, Output Mdl 24/48 VDC 2A, 55-1
 IC697MDL750, Output 24/48 VDC 0.5A, 54-1
 IC697MDL752, Output Mdl 12 VDC 0.5A, 53-1
 IC697MDL753, Out. 5/48 VDC 0.5A Neg, 52-1
 IC697MEM713/15/17/19, CMOS Exp Mem, 32-1
 IC697MEM731/32/33/35, CMOS 32 Bit, 33-1
 IC697PCM711, PCM, 34-1

IC697PWR710/712, PwrSply120/240VAC 125 VDC
55W, Version H (or later), 9-1

IC697PWR711/713, PwrSply120/240VAC 125 VDC
100W, Version H (or later), 10-1

IC697PWR720, Power Supply Adapter, 11-1

IC697RCM711, Redundancy Comms, 72-1

Input Modules

12 VAC 32 Pt IC697MDL252, 36-1

12 VDC Pos/Neg IC697MDL652, 43-1

120 VAC 16 Pt IC697MDL251, 41-1

120 VAC 32 Pt IC697MDL250, 39-1

120 VAC Isol 16 Pt IC697MDL240, 40-1

125 VDC Pos/Neg Logic IC697MDL640, 46-1

24 VAC 32 Pt IC697MDL253, 37-1

24 VDC Pos/Neg Logic IC697MDL653, 44-1

240 VAC Isol 16 Pt IC697MDL241, 42-1

48 VAC 32 Pt IC697DL254, 38-1

48 VDC Pos/Neg Logic IC697MDL654, 45-1

Analog Input System, 57-1

Interrupt IC697MDL671, 48-1

TTL Neg Logic 32 Pt IC697MDL651, 47-1

Interface Module for IC600 PLC, 67-1

Interface Modules

Workstation Int PS/2 IC640WMI920/320, 74-1

Workstation Int XT/AT IC640WMI910/310, 73-1

ISO 9000 Registration, 1-1

J

Jumper, Blank Slot Interrupt, 80-1

M

Miniconverter kit, 79-1

Model 351 CPU

Port 1 Pin Assignments, RS-232 Signals, 19-4, 20-4,
21-4, 22-4, 23-5, 24-5

Port 2 Pin Assignments, RS-485 Signals, 19-4, 20-4,
21-4, 22-4, 23-5, 24-5

Model 352 CPU

Port 1 Pin Assignments, RS-232 Signals, 19-4, 20-4,
21-4, 22-4, 23-5, 24-5

Port 2 Pin Assignments, RS-485 Signals, 19-4, 20-4,
21-4, 22-4, 23-5, 24-5

O

Output Modules

12 VDC 0.5A IC697MDL752, 53-1

120 VAC 0.5A IC697MDL350, 49-1

120 Volt AC 2A IC697MDL340, 50-1

120/240 VAC 2A Isol IC697MDL341, 51-1

24/48 VDC, 0.5A IC697MDL750, 54-1

24/48 VDC, 2A IC697MDL740, 55-1

5/48 VDC 0.5A Neg IC697MDL753, 52-1

Analog Output, 58-1

Relay 16 Pt IC697MDL940, 56-1

P

Port isolator, 78-1

Power Supplies

120/240 VAC, 125 VDC, 100W IC697PWR711/713,
Version H (or later), 10-1

120/240 VAC, 125 VDC, 55W IC697PWR710/712, Ver-
sion H (or later), 9-1

24VDC 90W, IC/CE697PWR724, 7-1

48 VDC 90W, IC/CE697PWR748, 8-1

Power Supply Adapter Module IC697PWR720, 11-1

Power Supply Expansion Cable, 76-1

Q

Quality System – ISO 9000, 1-1

R

Rack Fan Assembly IC697ACC721/724/744-1

Racks

Standard, 4-1

VME Integrator Racks IC697CHS782/783, 5-1

Redundancy Communications Module, 72-1

Registration, ISO 9000, 1-1

Remote I/O Scanner, 65-1

RS-485 Port Isolator, 78-1

S

Serial Comms Module, State Logic, 70-1

Slot, Blank, Interrupt Jumper, 80-1

Special Applications Modules

High Speed Counter IC697HSC700, 59-1

State Logic Processor AD697SLP700, 60-1

Specifications, 2-1

Standards, 2-1

State Logic Processor, 60-1

V

VME Integrator Racks, 5-1

VME Option Kit, 82-1

Voltage Expander Module, 57-1

W

Workstation Interface Modules PS/2, 74-1

Workstation Interface Modules XT/AT, 73-1